

# Important Notice

## Signature and Chop on Vehicle Registration Document (VRD)

The VRD **has to** contain signature of the registered vehicle owner, and the signature on the application form should match with that on the VRD when a relevant licensing application is submitted by the registered vehicle owner concerned. If the vehicle is owned by a company/organization, the VRD **has to contain** the signature of an authorized representative together with a company/organization chop and the chop on the application form **must be identical** with that on the VRD, otherwise this department will **not** process the licensing application.

## Requirement of Address Proof

The original or a copy of the proof of address issued within the last three months **has to** be produced when submitting a licensing application. In accordance with the relevant legislation, the Transport Department may suspend processing the application in the absence of address proof. [[Please refer to the list of acceptable proof of address](#)]

## Change of Address

According to the law, driving licence holders or registered vehicle owners have to notify the Transport Department within 72 hours of their change of address. Any person without reasonable excuse contravenes such requirement commits an offence and is liable to a fine of \$2,000. You may notify the Transport Department of change in address with your proof of new address in writing, through [GovHK](#) or by submitting [the specified form](#) (“Change of Personal Particulars or Vehicle Particulars”).

## Mail items with insufficient postage

Underpaid mail items are subject to surcharge by Hongkong Post. This department will not accept underpaid mail items, which will be returned to the sender (with return address) or disposed of (without return address) by the Hongkong Post. For proper delivery of your mail items to the department, and to avoid unnecessary delivery delay or unsuccessful delivery, please ensure your mail items bear sufficient postage with return address before posting. [[Please note the latest details about postage rates by Hongkong Post](#)]

## Submission of Identity Document

For application submitted by post/ via drop-in box, please **do not** submit the **original** identity document.

**運載超逾最高車輛重量許可證申請書**  
**Application For Excess Weight Permit**

填寫表格前請參閱後頁說明；所有資料均須以正楷填寫。本表格必須遞交一式四份。  
Please read the notes carefully before completing this form. All items should be completed in BLOCK LETTERS.  
This application form must be submitted in quadruplicate.

(本欄不必填寫 FOR OFFICIAL USE ONLY)

|   |  |
|---|--|
| O |  |
| P |  |

Receiving Officer's Signature \_\_\_\_\_  
Recommended/Not Recommended \_\_\_\_\_  
Approved/Not Approved \_\_\_\_\_  
Permit No. \_\_\_\_\_  
Permit Fee Received \_\_\_\_\_

**甲部**  
**PART A**

**申請人資料 PARTICULARS OF APPLICANT**

英文姓名／公司名稱 \_\_\_\_\_ 中文姓名／公司名稱 (如適用) \_\_\_\_\_

Name (In English) \_\_\_\_\_ Name (In Chinese, if applicable) \_\_\_\_\_

身分證明文件號碼／公司註冊證號碼 \_\_\_\_\_ ( )  
Identity Document No./ Certificate of Incorporation No. \_\_\_\_\_

住址／公司地址 RESIDENTIAL/COMPANY ADDRESS

「注意：本署是以駕駛執照持有人／登記車主的住址／公司地址(如以公司登記為車主)為他／她於本署的登記地址，並以該地址與他／她聯絡和郵寄函件。因此，申請人必須在本申請表填寫其最新的住址／公司地址。」

(Note: The residential address/company address (if using company as registered vehicle owner) of a driving licence holder/registered vehicle owner is his/her/its registered address in this Department, and will be used for the purposes of contact with him/her and mailing correspondence. Thus, the applicant must fill in his/her/its updated residential address/company address in this application form.)

室 Flat/Room \_\_\_\_\_ 樓 Floor \_\_\_\_\_ 座 Block \_\_\_\_\_  
如以中文書寫地址，必須清楚寫明樓層，以免郵遞失誤。

大廈／屋苑名稱 Name of Building/Estate \_\_\_\_\_

門牌號數及街道(或鄉村)名稱 Number and Name of Street (or Village) \_\_\_\_\_

地區 District \_\_\_\_\_

†  香港 Hong Kong  九龍 Kowloon  新界 New Territories

通訊地址 CORRESPONDENCE ADDRESS

「注意：如你以上所填報的住址／公司地址(如以公司登記為車主)並不能用作聯絡和郵遞用途，請在以下填寫你的通訊地址。」

(Note: If you cannot use the above residential /company address (if using company as registered vehicle owner) for the purposes of contact and mailing, please fill in below your correspondence address.)

室 Flat/Room \_\_\_\_\_ 樓 Floor \_\_\_\_\_ 座 Block \_\_\_\_\_  
如以中文書寫地址，必須清楚寫明樓層，以免郵遞失誤。

大廈／屋苑名稱 Name of Building/Estate \_\_\_\_\_

門牌號數及街道(或鄉村)名稱 Number and Name of Street (or Village) \_\_\_\_\_

地區 District \_\_\_\_\_

日間聯絡電話 Day Time Contact Tel. No.: \_\_\_\_\_

† 請於適當方格內加上「✓」號 Please tick the appropriate box

**乙部**  
**PART B**

**車輛細節**  
**Particulars of Vehicle**

車輛登記號碼(拖頭)  
Registration Mark (Tractor)

車輛登記號碼(拖車)  
Registration Mark (Trailer)

車輛總重(噸)  
Gross Combined Weight (Tonnes)

車輛尺寸(長 x 闊 x 高)(米)  
Vehicle Dimension (L x W x H) (metres)

|       |       |       |       |
|-------|-------|-------|-------|
| _____ | _____ | _____ | _____ |
| _____ | _____ | _____ | _____ |
| _____ | _____ | _____ | _____ |

請一併遞交有關車輛(包括拖頭及拖車)的繪圖，並須提供各軸間距離、每軸呎數、呎闊度、每軸負重量、拖頭及拖車的重量及負重量，以及總重量。

Please submit together a drawing of the vehicle (including tractor and trailer), and provide the spacing between axles, number of tyres in each axle, tyre width, axle weight, gross vehicle weight and loading of tractor and trailer, and the gross combined weight.

**丙部**  
**PART C**

**有效的第三者意外風險保險(必須出示保險單)**  
**Valid Third Party Risks Insurance (Certificate must be produced)**

保險公司名稱(非代理商) \_\_\_\_\_  
Name of Insurance Company (not agent)

保險單／臨時保單號碼 \_\_\_\_\_ 屆滿日期 \_\_\_\_\_  
Policy/Cover Note No. \_\_\_\_\_ Expiry Date

1. 申請理由

Reasons of Application

2. 路線詳情: (請書面列明路線詳情, 並提供有關路線圖。)

Details of Routes (Please state details of routes in writing and provide route map(s).)

3. 來往日期

Date of Movement

4. 來往時間

Time of Movement

本人經已詳讀並明白申請表內各項條款。本人聲明據本人所知, 上述填報的資料均屬詳盡確實, 且上述丁部的路線均有足夠通行高度/空間供該車輛(包括貨物)行駛。本人特此為上述車輛申請超逾最高車輛重量許可證。

本人以上聲明均屬真確事實。本人明白如故意在本申請表填報失實資料, 根據《道路交通條例》(第 374 章) 第 111 條第(3)款的規定, 本人可被判罰款 \$5,000 及監禁 6 個月。

本人委託 \_\_\_\_\_ (代理人姓名), 即身分證明文件號碼 \_\_\_\_\_ 的持有人為代理人, 代表本人提交及處理本申請, 包括領取相關牌照、許可證及/或其他文件。  
(註: 如申請表提供的資料曾作修改, 申請人須在旁加簽作實。)

I have read and understood the conditions attached to this form. I declare that to the best of my knowledge and belief the information given above is true and complete and the routes in Part D above are of sufficient headroom/clearance for movement of the vehicle inclusive of load. I hereby apply for Excess Weight Permit(s) for the above vehicle(s).

My declarations above are true and correct. I understand that if I knowingly make any statement or provide any information in this application form which is false in a material particular, I shall render myself liable under Section 111(3) of the Road Traffic Ordinance (Cap. 374) to a fine of \$5,000 and to imprisonment for 6 months.

I hereby appoint \_\_\_\_\_ (name of agent), holder of identity document number \_\_\_\_\_ as the agent to submit and handle this application on my behalf, including the collection of related licence, permit and/or other documents.  
(Note: If the information provided in this application form is amended, applicant shall sign next to the amended part for verification.)

申請人簽署

Signature of Applicant

日期

Date

## 發證條件 CONDITIONS OF ISSUE

1. 申請許可證的人士必須為該車車主。
2. 許可證持有人在該車輛進入有管理機關或擁有人限制車輛進出的任何地方或私家路，必須取得管理機關或擁有人的預先批准。
3. 不得在公路結構上進行令車輛顛簸的操控，例如變速或停車。
4. 申請人須確保不會對公路結構、路面及排水設施造成損毀。一旦造成損毀，申請人須負責支付修理費用。
5. 申請人/司機須確保車輛的車輛總重、組合式車輛總重及車軸重量不超過車輛製造商指明的有關技術上的設計重量。
6. 申請人須就每次行程路線取得警方總區交通部及路政署的事先批准，以確保不會對其他道路用者造成不必要的不便，或損毀道路路面及地底設施。如有需要，申請人應直接與負責有關設施的機構聯絡。
7. 必須提供護送車輛。
8. 有關車輛應盡可能使用地面路線。
9. 申請人應注意在開始行車時，必須備有一旦車輛發生故障或負載物脫離時所採用的應急計劃。
10. 車主/司機應確保車胎容量足夠應付所擬議的負載量。

1. The applicant should be the owner of the vehicle to which a permit is sought.
2. The permit holder shall seek the approval from the relevant authority prior to driving the vehicle in any area or private road of which the management authority or owner may restrict the access of the vehicle.
3. Jolting manoeuvres such as changing gear or stopping the vehicle on highway structure are not allowed.
4. The applicant should ensure that no damage to highway structures, road pavement and drainage will be caused. In the event that damage does occur, the applicant should be responsible for the repair cost incurred.
5. The owner/driver should ensure that the gross vehicle weight (G.V.W.), gross combined weight (G.C.W.) and axle weights of the vehicle do not exceed the relevant technical design weights specified by the manufacturer.
6. Prior routing approval for each movement must be sought from the Regional Police and Highways Department in order to ensure that no undue inconvenience is caused to other road users and no damage is caused to road pavements and underground utilities. The applicant should liaise with the utility undertakers direct when necessary.
7. Escort vehicles must be provided.
8. The vehicle should use alternative at-grade routing as far as possible.
9. It should be noted that contingency plans for vehicle breakdowns or detachment of load must be in place before the operation commences.
10. The owner/driver should ensure that the tyre capacity is adequate for proposed loadings.

## 注意事項 NOTES FOR ATTENTION

1. 如任何駕駛執照持有人/登記車主曾向運輸署署長提供其姓名、地址或身分證明文件有所改變，他/她須在改變出現後 72 小時內以書面通知運輸署署長，並需提交有關改變的證明。任何人無合理辯解而違反此規定，即屬犯罪，可處罰款 \$2,000。如屬姓名的改變或身分證明文件的改變，駕駛執照持有人/登記車主亦須將現有的駕駛執照正本(如持有)、駕駛教師執照正本(如持有)、車輛登記文件正本(如持有)、車輛牌照(如持有)及自訂登記號碼分配證明書(如持有)送交運輸署署長，以作修改。
2. 運輸署署長在處理牌照申請時，可要求申請人出示其現時地址的證明(住址/公司地址(如以公司登記為車主)及通訊地址，例如水/電/煤氣/手提電話費單或銀行信件等，而該地址證明須距今不超過三個月)，以及可在申請人出示該等證明之前，暫停處理該申請。因此，請申請人帶同其現時地址的證明，並在牌照事務處人員要求下，出示其地址證明。
3. 所有在本署以你的身分證明文件/公司註冊證號碼登記的車輛牌照或駕駛執照的記錄，會根據你在此表格內填報的地址而同時更改。
4. 在完成辦理你的申請後，你所提交的證明文件副本將會被銷毀。

1. If a change occurs in the name, address or identity document of a driving licence holder/registered owner previously provided by the driving licence holder/registered owner to the Commissioner for Transport, the driving licence holder/registered owner shall, within 72 hours of the change, notify the Commissioner for Transport in writing with the proof of change. Any person who without reasonable excuse contravenes such requirement commits an offence and is liable to a fine of \$2,000. For cases of change of name or change of identity document, the driving licence holder/registered owner shall also deliver to the Commissioner for Transport the existing original driving licence (if applicable), original driving instructor's licence (if applicable), original vehicle registration document (if applicable), vehicle licence (if applicable) and Certificate of Allocation of Personalized Registration Mark (if applicable) for amendment.
2. The Commissioner for Transport may, in processing licensing application, require the applicant to produce proof of his/her address (residential/company address (if using company as registered vehicle owner and correspondence address, e.g. water/electricity/gas/mobile phone bill and bank correspondence), and may suspend the processing of the application until the production of such proof. Therefore, applicants please bring along with address proof issued within the last three months for presentation as and when requested by officers of Licensing Office.
3. For any change of address notified in this application form, all vehicle/driving licence records of the applicant under the same identity document /Certificate of Incorporation held by this Department will also be changed.
4. Copy of your submitted supporting document(s) will be destroyed after processing your application.

## 遞交申請表 Submission of Application

請將申請表親自或由代理人遞交或郵寄至運輸署以下任何一間牌照事務處，由於申請必須諮詢警察交通部／路政署，請盡早提交申請。

### 運輸署牌照事務處

1. 香港牌照事務處  
香港金鐘道 95 號統一中心 3 樓  
2804 2642
2. 九龍牌照事務處  
九龍長沙灣道 303 號長沙灣政府合署 2 樓  
2150 7714

如需查詢各運輸署牌照事務處服務時間，可致電 2804 2600 或瀏覽運輸署網站 [www.td.gov.hk](http://www.td.gov.hk)

Please submit the application in person or by agent or by post to Hong Kong or Kowloon Licensing Office of Transport Department. Since applications will be considered in consultation with the Traffic Police/Highway Office, please submit the application as early as possible.

1. Hong Kong Licensing Office  
3/F United Centre,  
95 Queensway,  
Hong Kong  
2804 2642
2. Kowloon Licensing Office  
2/F Cheung Sha Wan Government Offices,  
303 Cheung Sha Wan Road,  
Kowloon  
2150 7714

For enquiry on service hours of Transport Department licensing offices, please call 2804 2600 or visit our website [www.td.gov.hk](http://www.td.gov.hk)

## 所需文件及費用 REQUIRED DOCUMENTS AND FEE

遞交申請表時請出示以下文件：

- 車主的香港身份證或護照／公司註冊證（商業登記證不會被接納）；而身分證證明文件的影印本亦會被接納作核對用，本署會於辦理你的申請後將副本銷毀。
- 車輛登記文件副本。
- 有關車輛（包括拖頭及拖車）的繪圖，並須提供各軸間距離、每軸呎數、呎闊度、每軸負重量、拖頭及拖車的重量及負重量，以及總重量。
- 顯示車輛路線的地圖。
- 以車主名義投保該車的運載超逾最高車輛重量貨物第三者意外風險有效證明書。
- 應繳的費用 – 每張許可證的申請費用為 \$110 [有關申請費用或會更改。如欲知最新費用，你可於本署牌照事務處的詢問處查詢、或致電顧客服務熱線 2804 2600 / 1823 電話中心查詢、參閱牌照事務處的牌照費用表 (TD341) 或瀏覽運輸署網頁 ([www.td.gov.hk](http://www.td.gov.hk))。如以支票/銀行本票付款，請劃線並寫明「香港特別行政區政府」為收款人，並在支票/銀行本票背面寫上你的姓名、身分證文件號碼及日間聯絡電話。請勿郵寄現款。

When you submit your application please also produce: --

- Hong Kong Identity Card or Passport/Certificate of Incorporation of a company. (Business Registration Certificate will not be accepted). Photocopy of the identity documents is acceptable and will be destroyed after the processing of your application.
- Copy of Vehicle Registration Document.
- Drawing of the vehicle (including tractor and trailer), and provide the spacing between axles, number of tyres in each axle, tyre width, axle weight, gross vehicle weight and loading of tractor and trailer, and the gross combined weight..
- Map(s) showing the routes of the vehicles.
- A valid Third Party Risk Insurance Certificate on Excess Weight covering the use of the vehicle in the name of the owner.
- The appropriate fee —the application fee per permit is \$110 [The application fee may be subject to change. For enquiry of updated application fees, you may make enquiry at the enquiry counters of licensing office or from Customer Service Hotline 2804 2600/1823 Call Center, refer to the licence fees table (TD341) from licensing offices, or visit Transport Department's website:[www.td.gov.hk](http://www.td.gov.hk) for information.] if paid by cheque/cashier order, please make cheque/cashier order payable to “**The Government of the Hong Kong Special Administrative Region**” and crossed. Please write down your name, identity document number and daytime contact telephone number on the back of the cheque/cashier order. Cash should not be sent by post.

## 郵遞申請 APPLICATION BY POST

如你以郵寄遞交申請表，請填寫下列資料 PLEASE FILL IN THE FOLLOWING ITEMS

1. 請在支票/銀行本票背面寫上你的姓名、車輛登記號碼及日間聯絡電話。  
Please write down your Name, Vehicle Registration Mark and Day Time Contact Telephone No. on the back of the cheque/cashier order.
3. 為方便本署郵寄本申請表所申請的許可證給你，請在以下填上你的姓名/公司名稱(如以公司為登記車主)及你於本申請表甲部所填寫的住址/公司地址/通訊地址。  
To facilitate us to mail the permit applied in this application form to you, please fill in your name/company name (if using company as registered vehicle owner) and residential address/company address/correspondence address provided in Part A of this application form.

2. 請填上你的付款資料。

Please fill in the remittance details.

銀行名稱 Name of Bank: \_\_\_\_\_

付款總額 Amount Paid: \_\_\_\_\_

支票/銀行本票號碼

Cheque / Cashier order No. \_\_\_\_\_

姓名 Name : \_\_\_\_\_

住址/公司地址/通訊地址 Residential/Company/Correspondence Address  
\_\_\_\_\_  
\_\_\_\_\_



車輛繪圖樣本

Sample Drawing of Vehicle

車牌號碼: AB4321 / 98765T 總重量: XX 噸

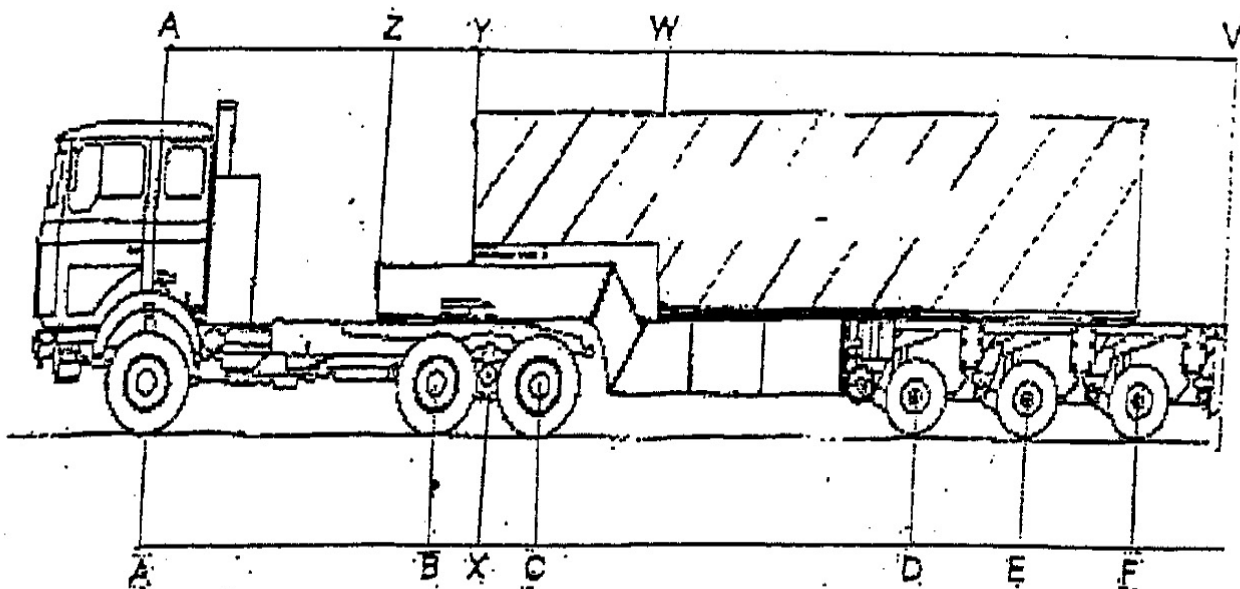

軸距

|    |    |    |    |    |    |      |           |    |
|----|----|----|----|----|----|------|-----------|----|
| AB | XX | mm | YD | XX | mm | ZW   | XX        | mm |
| BC | XX | mm | DE | XX | mm | WV   | XX        | mm |
| AY | XX | mm | EF | XX | mm | Y is | (trailer) |    |
| AX | XX | mm | CD | XX | mm |      |           |    |
| AC | XX | mm |    |    |    |      |           |    |

拖頭每軸呔數: A: XX B: XX C: XX 拖頭呔數總數: XX

拖頭呔闊度: A: XX B: XX C: XX

拖架每軸呔數: D: XX E: XX F: XX 拖架呔數總數: XX

拖架呔闊度: D: XX E: XX F: XX

每軸負重 A: XX B: XX C: XX D: XX E: XX F: XX

拖頭自重: XX Tons 拖架自重: XX Tons 貨物自重: XX Tons 總重量: XX Tons

拖頭負重: XX Tons 拖架負重: XX Tons

### 收集目的

- 運輸署會使用透過本申請表所獲得的個人資料作下列用途：
  - 理有關審批你在本申請表中所提出的申請的事務；
  - 依照道路交通（車輛登記及領牌）規例第 4(2) 條的規定，保存一份車輛記錄，讓市民索閱；  
(只適用於與車輛有關的申請)
  - 依照道路交通（駕駛執照）規例第 39 條的規定，保存一份詳列駕駛執照上各細項的記錄；  
(只適用於與駕駛執照有關的申請)
  - 辦理有關交通及運輸的事務；及
  - 方便運輸署與你聯絡。
- 你必須提供本申請表格所要求的個人資料。假如你未能提供所需資料，你的申請可能不獲接納。

### 獲轉交資料的部門／人士

- 你透過本申請表所提供的個人資料會向下列人士／部門公開：
  - 其他政府部門、決策局及有關機構，以作上述第 1 段所列的用途；
  - 任何人士，以作上述第 1 段 (b) 項所列的用途；及
  - 隧道公司、青馬管制區營運者及青沙管制區營運者，以便該等機構執行與交通及運輸有關的法定職責。

### 索閱個人資料

- 根據個人資料（私隱）條例第 18 及 22 條及附表 1 第 6 條，你有權索閱及修正你的個人資料。你的索閱權包括獲取本申請表所提供的個人資料副本一份。

### 查詢

- 有關透過本申請表收集的個人資料的查詢，包括索閱及修正資料，應寄往：

香港  
金鐘道 95 號  
統一中心 3 樓  
牌照事務組  
行政主任／FRT 收啟

### Purposes of Collection

- The personal data provided by means of this form will be used by Transport Department for the following purposes :
  - activities relating to the processing of your application in this form;
  - maintenance of a register of vehicles for public access under regulation 4(2) of the Road Traffic (Registration and Licensing of Vehicles) Regulations;  
(applicable to vehicle-related applications only)
  - maintenance of a record of particulars of driving licences under regulation 39 of the Road Traffic (Driving Licences) Regulations;  
(applicable to driving licence - related applications only)
  - activities relating to traffic and transport matters; and
  - facilitating communication between Transport Department and yourself.
- It is obligatory for you to supply the personal data as required by this form. If you fail to supply the required data, your application may be refused.

### Classes of Transferees

- The personal data you provided by means of this form may be disclosed to :
  - other Government departments, bureaux and relevant organization for the purposes mentioned in paragraph 1 above;
  - any person for the purpose mentioned in paragraph 1(b) above; and
  - tunnel companies, Tsing Ma Control Area operator and Tsing Sha Control Area operator for execution of their statutory duties in traffic and transport matters.

### Access to Personal Data

- You have a right of access and correction with respect to personal data as provided for in sections 18 and 22 and principle 6 of Schedule 1 of the Personal Data (Privacy) Ordinance. Your right of access includes the right to obtain a copy of your personal data provided by this form.

### Enquiries

- Enquiries concerning the personal data collected by means of this form, including the making of access and corrections, should be addressed to:

Executive Officer/FRT  
Licensing Section  
3/F, United Centre  
95 Queensway  
Hong Kong