

GENERAL NOTE

The Transport Planning and Design Manual (the TPDM) consists of eleven volumes and is published primarily as a working document for Transport Department staff. It also provides information and guidance to others involved in the planning and design of transport infrastructures in Hong Kong.

It is intended that the information contained herein will be periodically revised to take account of the most up-to-date knowledge and experience. The inevitable time-lag however, means that certain sections may at a particular time be unavoidably not up-to-date. For this and other reasons, the standards contained in this manual should not be followed rigidly but rather treated as a framework within which professional judgment should be exercised to reach an optimum solution.

Generally speaking, the standards contained in the TPDM generally apply to new traffic and transport facilities and should not be considered as exhaustive. Situation may arise for which considerations and requirements are not fully covered by the TPDM. Practitioners are particularly required to exercise professional judgement when dealing with existing facilities that are subject to site constraints, and to endeavour to take into account the views from stakeholders. Practitioners are also advised to make reference to other publications relevant to their designs such as the latest legislations, code of practices, guidelines, datasets, etc. before applying the TPDM.

Transport Planning & Design Manual

VOLUME 9- Public Transport

- Chapter 1 - Introduction
 - 1.1 References
 - 1.2 Introduction
 - 1.3 Objectives
 - 1.4 A balanced network
 - 1.5 Railways
 - 1.6 Franchised buses
 - 1.7 Public light buses
 - 1.8 Taxis
 - 1.9 Trams
 - 1.10 Non-franchised buses
 - 1.11 Ferries
 - 1.12 Public transport facilities
- Chapter 2 - Franchised Bus
 - 2.1 References
 - 2.2 Introduction
 - 2.3 The Bus Design
 - 2.4 Bus Stops
 - 2.5 Bus Laybys
 - 2.6 Bus Shelters
 - 2.7 Design Standards for Bus Terminal Facilities
 - 2.8 Built Over Bus Termini
 - 2.9 Bus Depots
- Chapter 3 - Public Light Buses
 - 3.1 References
 - 3.2 Introduction
 - 3.3 Policy Guidelines
 - 3.4 Public Light Bus (Scheduled) Services - Green Minibuses
 - 3.5 Public Light Bus Stands and Termini
 - 3.6 Stopping Places
 - 3.7 Public Light Bus Prohibition and Stopping Restriction
- Chapter 4 - Taxis
 - 4.1 References
 - 4.2 Introduction
 - 4.3 Administration and Control
 - 4.4 Taxi Stands
- Chapter 5 - (Not Use)
- Chapter 6 - Non-Franchised Buses
 - 6.1 References
 - 6.2 Introduction
 - 6.3 Planning Guidelines
- Chapter 7 - Ferries
 - 7.1 References
 - 7.2 Introduction
 - 7.3 Ferry Services
 - 7.4 Ferry Vessels
 - 7.5 Ferry Piers
- Chapter 8 - Public Transport Interchange
 - 8.1 References

- 8.2 Introduction
- 8.3 Project Planning
- 8.4 Design Requirements for Public Transport Interchange
- 8.5 Patronage and Pedestrian Demand
- 8.6 Public Transport Provisions
- 8.7 Layout Considerations
- 8.8 Passenger Information Facilities
- 8.9 Environmental Design
- 8.10 Safety and Security Facilities
- 8.11 Passenger Facility Requirement
- 8.12 Operators Facilities

TPDM Volume 9 Chapter 1 – Introduction

1.1 References

- 1 Hong Kong Government, “Moving into the 21st Century – The White Paper on Transport Policy in Hong Kong”, January 1990.
- 2 Hong Kong Government, “Hong Kong Planning Standard & Guidelines, Chapter 8, Internal Transport Facilities”.
- 3 Transport Department, “Technical Report – Third Comprehensive Transport Study”, 1999.
- 4 Transport Department, “Working Paper 9 – Design Guidelines for Public Transport Interchanges” for Studies on Coordination of Other Public Transport Services with New Railways, January 2000.
- 5 Transport Bureau, "Hong Kong Moving Ahead - A Transport Strategy for the Future", October 1999.

1.2 Introduction

- 1.2.1 Hong Kong with a land area of only 1,097 square kilometres of which about 16 percent is built up, has a population of more than six million. Every day, over 10 million passenger journeys are made on a public transport system which includes two high capacity railways, buses, minibuses, taxis, trams and ferries.

1.3 Objectives

- 1.3.1 To meet the economic, social and recreational needs of the community, the government aims to provide a safe, efficient and reliable transport system. It does this by:
- (i) expanding and improving the transport infrastructure;
 - (ii) improving the availability and quality of public transport services; and
 - (iii) managing road use to reduce congestion and promote safety.
- 1.3.2 In October 1999, the Government published the “Hong Kong Moving Ahead – A Transport Strategy for the Future” on the basis of the recommendations of the Third Comprehensive Transport Study (CTS-3). One of the major transport strategies in Hong Kong is to provide a balanced public transport network which encourages the maximum utilization of railways. Franchised bus and other public transport services will continue to play an important role in areas not accessible by railways as well as feeding passengers to railways. For the purpose of enhancing inter-modal coordination, a network of high standard public transport interchanges should be provided.

1.4 A Balanced Network

- 1.4.1 To improve the availability and quality of public transport services, there should be a balanced network offering a sufficiently broad range of public transport services with emphasis on more and better use of the efficient mass carriers i.e. rails and buses, supplemented by other modes providing complementary services. Without proper co-ordination, there would be over provision of services in areas of popular demand, undermine the viability and efficiency of various modes leading to an ultimate reduction in passenger choice and pressure for higher fares. Furthermore, there would be inadequate services in the less populated or developing areas. The role and characteristics of each mode in the public transport system is as follows:

1.5 Railways

- 1.5.1 Railways, being the most environmentally friendly form of mass transport, form the backbone of the public transport system in Hong Kong.
- 1.5.2 Hong Kong's railways are run by the Mass Transit Railway Corporation Limited (MTRCL). In December 2007, MTRCL was granted a 50-year franchise to operate the MTR and ex-Kowloon-Canton Railway (KCR) systems. As at end-2024, the total length of MTR network is about 270 km, including nine local lines¹, Airport Express (AEL), the Hong Kong Section of Guangzhou-Shenzhen-Hong Kong Express Rail Link (XRL) and Light Rail.
- 1.5.3 The nine local lines, AEL and XRL networks comprise a total of 99 stations. The total length of the nine local lines is about 200 km, with the East Rail Line commissioned in 1910 by the former KCR Corporation and Kwun Tong Line was the first passenger train of MTRCL which started its operation in 1979. The 35 km long AEL, which was commissioned in 1998, connects the urban area to the Hong Kong International Airport and AsiaWorld-Expo, as well as providing in-town check-in facilities in some stations. The Hong Kong Section of XRL was commissioned in 2018. It has a route length of 26 km and connects with the national high speed rail network. The XRL trains provide direct service between Hong Kong West Kowloon Station and more than 95 Mainland destinations.
- 1.5.4 The Government promulgated the Hong Kong Major Transport Infrastructure Development Blueprint (the Blueprint) in December 2023 to outline the future development of the city's railway and major road networks to meet Hong Kong's long-term transport and logistics demand up to 2046 and beyond.
- 1.5.5 It is recommended in the Blueprint to take forward the enhanced "Three Railways and Three Major Roads" and the "Two Railways and One Major Road". The former involves three strategic railway proposals, namely the Hong Kong-Shenzhen Western Rail Link (Hung Shui Kiu-Qianhai) (HSWRL), the Central Rail Link and the Tseung Kwan O Line Southern Extension. Meanwhile, the latter comprises two strategic railway proposals, namely the Northern Link Eastern Extension and the Northeast New Territories Line.
- 1.5.6 For the cross-boundary railway projects, the governments of Hong Kong and Shenzhen jointly pursue through the Task Force for Hong Kong-Shenzhen Cooperation on Cross-Boundary Railway Infrastructure and its Technical Group. Projects currently being taken forward include the HSWRL mentioned above, which connects the northwestern part of Hong Kong and Qianhai in Shenzhen, and the Northern Link Spur Line which provides a direct link to the new Huanggang Port in Shenzhen via the Hong Kong-Shenzhen Innovation and Technology Park in Lok Ma Chau Loop.

¹ The nine local lines include Kwun Tong Line, Tsuen Wan Line, Island Line, Tseung Kwan O Line, South Island Line, Tung Chung Line, Disneyland Resort Line, East Rail Line and Tuen Ma Line.

1.5.7 As pointed out in the 2024 Policy Address, the Government is actively following through the transport infrastructure projects recommended in the Blueprint to enhance Hong Kong's railway and major road networks. Upon completion of railway projects under construction and planning, the total length of railways in Hong Kong will be increased by about 44% to nearly 390 km. The following eight railway projects will be completed between 2027 and 2035:

- Kwu Tung Station on East Rail Line
- Tung Chung Line Extension
- Hung Shui Kiu Station on Tuen Ma Line
- Oyster Bay Station on Tung Chung Line
- Tuen Mun South Extension
- Science Park / Pak Shek Kok Station on East Rail Line
- Northern Link Main Line and Spur Line
- Hong Kong-Shenzhen Western Rail Link

In addition to large-scale transport infrastructure, the Government is also taking forward smart and green mass transit systems in Kai Tak, East Kowloon and Hung Shui Kiu/Ha Tsuen New Development Area.

1.6 Franchised Buses

1.6.1 As a mass carrier, buses are more flexible than rail because their routes and service levels can be more readily adjusted to meet changing demand, particularly in developing areas. They are the most efficient road-based passenger carrier. Buses should remain the prime mode for areas not accessible by railways and feeding passengers to railways.

1.6.2 At present, there are four franchised bus companies in Hong Kong collectively providing the main means of transport for the travelling public:

- (i) The Kowloon Motor Bus Company (1933) Ltd.
- (ii) Citybus Limited
- (iii) New Lantao Bus Company (1973) Ltd.
- (iv) Long Win Bus Company Ltd.

1.7 Public Light Buses

- 1.7.1 Public light buses (PLBs) are minibuses with not more than 19 seats. Their number is fixed at a maximum of 4,350 vehicles. The PLBs are used for scheduled services (green minibuses) or non-scheduled services (red minibuses). The red and green minibus routes are normally provided in areas where a public transport demand exists but is insufficient to financially sustain the operation of high capacity modes of public transport.
- 1.7.2 Red minibuses are free to operate anywhere, except where special prohibitions apply, without control over routes or fares.
- 1.7.3 Green minibuses operate on fixed routes at fixed fares which are generally somewhat higher than those of franchised buses.
- 1.7.4 In line with government's policy to convert red minibuses to green, more new scheduled routes will continue to be identified.

1.8 Taxis

- 1.8.1 Taxis provide a personalised and point-to-point transport service for passengers. Taxis are less efficient user of road space when compared with other public transport modes. They have a small carrying capacity and tend to congregate in the congested areas where demand is the highest and will ply for hire on the roads without passengers.
- 1.8.2 Different taxis have designated operating areas. Urban taxis (coloured red) operate in most areas in Hong Kong (except Tung Chung Road and roads in south Lantau). New Territories taxis (coloured green) mainly operate in the north-eastern part (i.e. north of Sha Tin) and north-western part (i.e. north of Tsuen Wan) of the New Territories. Lantau taxis (coloured blue) operate only on Lantau Island and Chek Lap Kok. All taxis are allowed to provide services at the passenger terminals of Hong Kong International Airport, the Hong Kong Section of Hong Kong-Zhuhai-Macao Bridge and Hong Kong Disneyland.
- 1.8.3 The demand for taxi services, to certain extent, is affected by the economy of Hong Kong. The Government has all along followed the established practice in considering the need to issue new taxi licenses. Relevant considerations include the public demand for taxi services, operating conditions of the taxi trade, and the likely impact of the increase in the number of taxis on traffic conditions. At the same time, the TD will take into consideration the actual traffic situation and the opinion of residents in the district, etc, with a view to setting up more "taxi parking spaces", relaxing no-stopping restriction, and designation of taxi drop-off points to enhance the daily operating environment of the taxi trade where feasible.
- 1.8.4 With a view to enhancing the taxi service quality and promoting the development of the taxi industry in the long run, the TD introduced a taxi fleet regime. Through the issue of the taxi fleet licences, TD can regulate the operation and management of taxi fleets through licensing conditions, including the requirements in relation to fleet size, age of vehicles and services to be provided by fleet licensees, such as the provision of online booking channels and e-payment means, as well as the installation of in-vehicle CCTV systems and technological devices to enhance driving safety.

1.9 **Trams**

- 1.9.1 Trams play an important role on Hong Kong Island particularly in meeting the demand of short distance passengers.
- 1.9.2 Electric trams have been running in Hong Kong since 1904. Hong Kong Tramways runs seven routes on 13-km of double tracks along the northern shore of Hong Kong Island between Kennedy Town and Shau Kei Wan, and about 3-km of single track around Happy Valley.

1.10 Non-franchised Buses

- 1.10.1 Non-franchised bus service is a collective term for bus service which is operated by operator(s) without a franchise granted under the Public Bus Services Ordinance (Cap. 230). The operation of non-franchised bus service requires a Passenger Service Licence issued by Commissioner for Transport under Section 27 of the Road Traffic Ordinance (Cap. 374).
- 1.10.2 Non-franchised buses play a supplementary role in the public transport system. They are primarily engaged in running tour service, hotel service, student service, employees' service, contract hire service, residents' service and international passenger service. Permitting non-franchised bus operators to provide services to schools and work places helps reduce the peak-hour passenger demand on franchised bus service, and hence enables franchised bus operators to keep down the level of resources left idle during the off-peak period. This will help stabilize the fare level of franchised bus service.
- 1.10.3 In addition, the Hong Kong Society for Rehabilitation receives government subvention to operate Rehabus services which provides a door-to-door transport service for people who have serious mobility difficulties to travel to work and school, or participate in social and recreational activities.

1.11 Ferries

- 1.11.1 Ferries are an essential mode for travelling to outlying islands and a supplementary mode of transport to cross-harbour buses and the MTR in the urban area. At present, most of the ferry services in Hong Kong are operated under a licensing system and licensed operators are not required to prepare forward planning programme. Normally, Transport Department is responsible for planning of ferry services and the factors which will be taken into account in planning of new routes include: availability of piers, financial viability of the route, provision of alternative services and any impact on existing route.

1.12 Public Transport Facilities

- 1.12.1 To cater for the public transport demand, it is necessary to provide essential facilities (e.g. stands, terminals and interchanges, etc.) to enhance the operation of different services. The guidelines for provision of these facilities are indicated in Chapter 2-8.

TPDM Volume 9 Chapter 2 – Franchised Bus

2.1 References

1. Greater Manchester Passenger Transport Executive (1978) *Physical design standards for bus services*, U.K.
2. Planning Department *Hong Kong Planning Standards and Guidelines*, HKSAR
3. Transport Bureau (1999) *Hong Kong Moving Ahead: A Transport Strategy for the Future*, HKSAR
4. Transport Department (1999) *Guideline for Provision of Bus Shelters and Advertising Panels*, HKSAR
5. Transport Department (1999) “*Planning for Bus Depots*” Working Paper, HKSAR
6. Transport Department (1999) *The Third Comprehensive Transport Study: Final Report and Technical Report*, HKSAR
7. Transport Department (2000) *Annual Transport Digest 2000*, HKSAR
8. Transport Department (2000) *Studies on Coordination of other Public Transport Services with New Railways: Working Paper No. 9 - Design Guidelines for Public Transport Interchanges*, HKSAR
9. Transport Department (2020) *Departmental Circular No. 4/2020 - Guideline on Designating Column-Free Areas in New Covered Public Transport Interchanges*, HKSAR

2.2 Introduction

2.2.1 At present, there are four franchised bus companies in Hong Kong collectively providing the main means of transport for the travelling public:

- (i) The Kowloon Motor Bus Company (1933)Ltd. (KMB)
- (ii) Citybus Limited(Citybus)
- (iii) New Lantao Bus Company (1973) Ltd. (NLB)
- (iv) Long Win Bus Company Ltd.(LW)

2.2.2 In October 1999, the government published the policy initiatives in the “Hong Kong Moving Ahead – A Transport Strategy for the Future” on the basis of the recommendations of the Third Comprehensive Study (CTS-3). One of the major transport strategies in Hong Kong is to provide a balanced public transport network which encourage the maximum utilization of railways. Franchised bus services will continue to play an important role in area not accessible by railways as well as feeding passengers to the railways.

2.3 The Bus Design

2.3.1 Introduction

2.3.1.1 In order to appreciate the needs of buses in the urban fabric, it is necessary to understand their physical characteristics and limitations. Two features distinguish the bus from the average road vehicle, namely its size and the need to accommodate standing and moving passengers whilst in motion. These two characteristics affect the basic requirements for physical planning and design of the roads on which buses run.

2.3.1.2 This chapter therefore begins by exploring one of the most important aspects of the bus on the geometric design of highways and bus termini - the swept path. It then goes on to outline the specific detail of the bus fleet operated by KMB, Citybus, NWFB and LW. Buses owned by NLB will not be highlighted because they are largely small mini-buses or single deckers deployed to suit their special operating environment. The inclusion of NLB's fleet would distort any attempt to derive a design bus. The analysis of the fleet of KMB, Citybus, NWFB and LW has been used to arrive at a standard design bus upon which to base design standards.

2.3.2 The Components of the Swept Path

2.3.2.1 The area of carriageway required for a bus to make any given manoeuvre is determined by the swept path described by the vehicle. The following paragraphs of this section outline in detail the various components of the swept path, and seek to explain in the relative importance of incorporating sufficient allowance within the geometric design of roads and bus termini in order to adequately cater for the bus.

2.3.2.2 The swept path described by the bus is the most important characteristic in designing roads or termini for buses. The swept path itself will vary considerably according to the type of vehicle, its speed, the skill of the driver and may even vary between different vehicles of the same type. Diagrams 2.3.2.1 and 2.3.2.2. show the swept paths described by a typical 12 metre long rigid vehicle during tests of certain basic manoeuvres under ideal conditions utilising full lock at low speeds.

2.3.2.3 In the United Kingdom, a number of tests had been carried out to verify the various components of the swept path. Diagram 2.3.2.3 is the basis for the analysis of the components of the swept path, comprising a 90° turn on a full right-hand lock. Diagram 2.3.2.4 shows the method of calculating the internal and external radii of the swept path and the transition periods on approach and exit.

2.3.2.4 The transition curves described by the appropriate points ("A" and "a" Diagram 2.3.2.3) on the body of a bus theoretically represent the locus of points of ever-decreasing radius in the case of the entry path (from infinity to full lock), and vice versa in the case of the exit path. In practice however the appropriate single radius circular curve joining the tangent point on the bus body to the tangent point on the respective design curve is sufficient to represent the theoretical curve described above.

2.3.2.5 Whilst on the design lock, the front external corner of the bus (point "A") following external radius 'R', must travel faster than point "a" over the rear axle following internal radius "r" Whilst on zero lock during the approach and departure paths, both point "A" and point "a" must assume the general speed of the whole vehicle, by virtue of the fixed relationship between points "A" and "a" on the rigid body of the bus. During the transition zones however, point "A" must be accelerating and decelerating respectively in relation to point "a", but, as the time taken for each transition period is the same for both points, point "A" must travel further than point "a". This is confirmed by their respective arc lengths A1-A2/a1-a2 and A3-A4/a3-a4 shown in Diagrams 2.3.2.3 and 2.3.2.4.

2.3.2.6 It should be noted that the points at which the entry transition ends, (point A2) and the exit begins (point A3) are, within limits, somewhat arbitrary in that those shown represent those peculiar to one driver of one vehicle at one speed and one rate of application of lock. However, the results of several independent tests confirm that they are fairly representative, and that the variations of driver, manoeuvre speed, etc., will not significantly alter the swept path of the vehicle manoeuvre, nor the relationship between the approach position 1 and departure position 4.

2.3.2.7 When the entry path transition period is studied it will be seen from test results that both points ("A" and "a") move in a forward and sideways direction, which represents the time taken to apply the design lock. Point "A" forms a tangent (point "A2") with the design radius "R" at a point somewhere between the intersection of the design radius "R" and the centreline of the bus produced, and the inside line of the bus body produced. The position of the bus at the start of the manoeuvre (position 1) also appears to be related to this latter point, being some 5m in

DIAGRAM 2.3.2.1: 180° TURNS, INCLUDING A TYPICAL REVERSE-CURVE EXIT PATH FOR 12m BUS

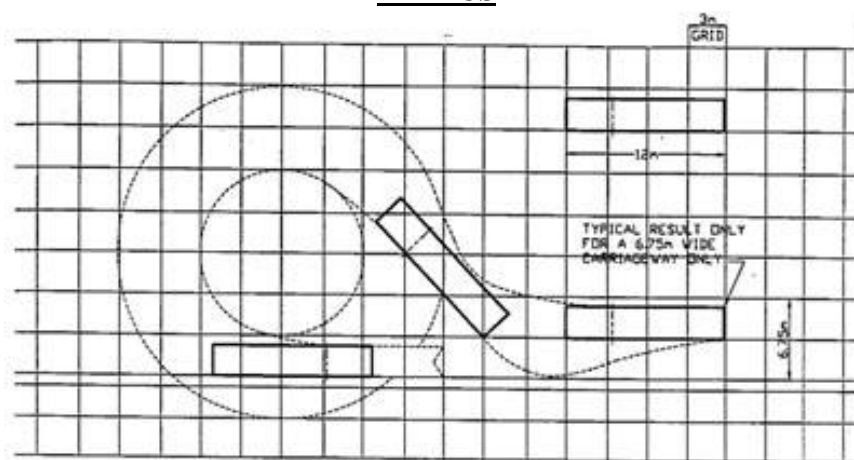

DIAGRAM 2.3.2.2: SWEEP PATHS FOR 135°, 90° AND 45° TURNS FOR 12m BUS

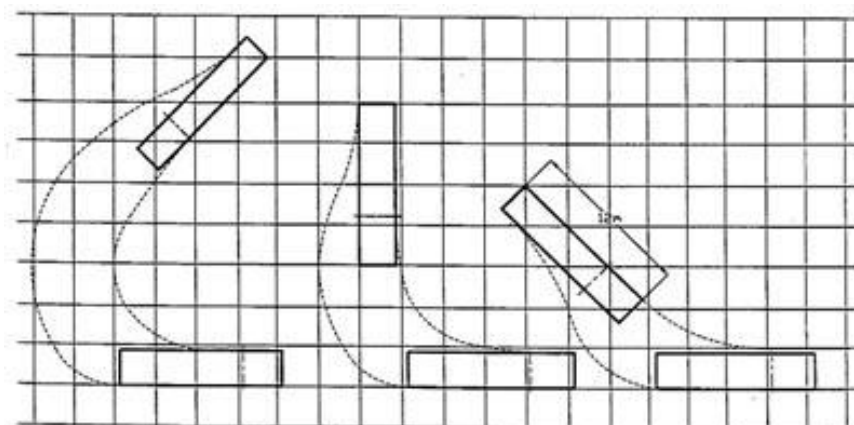
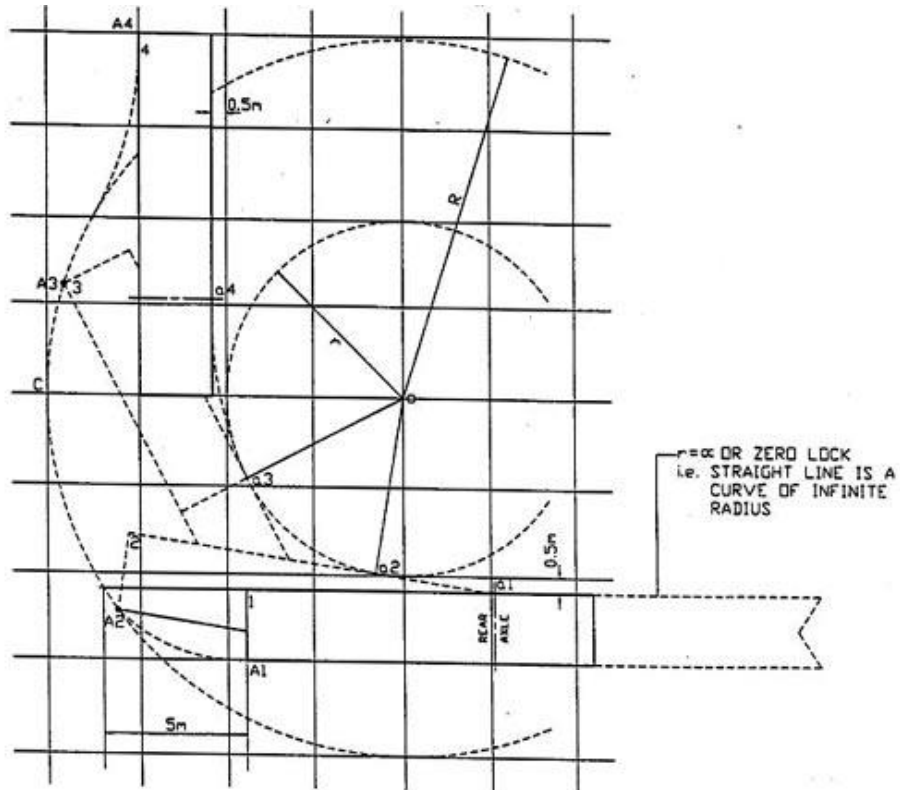
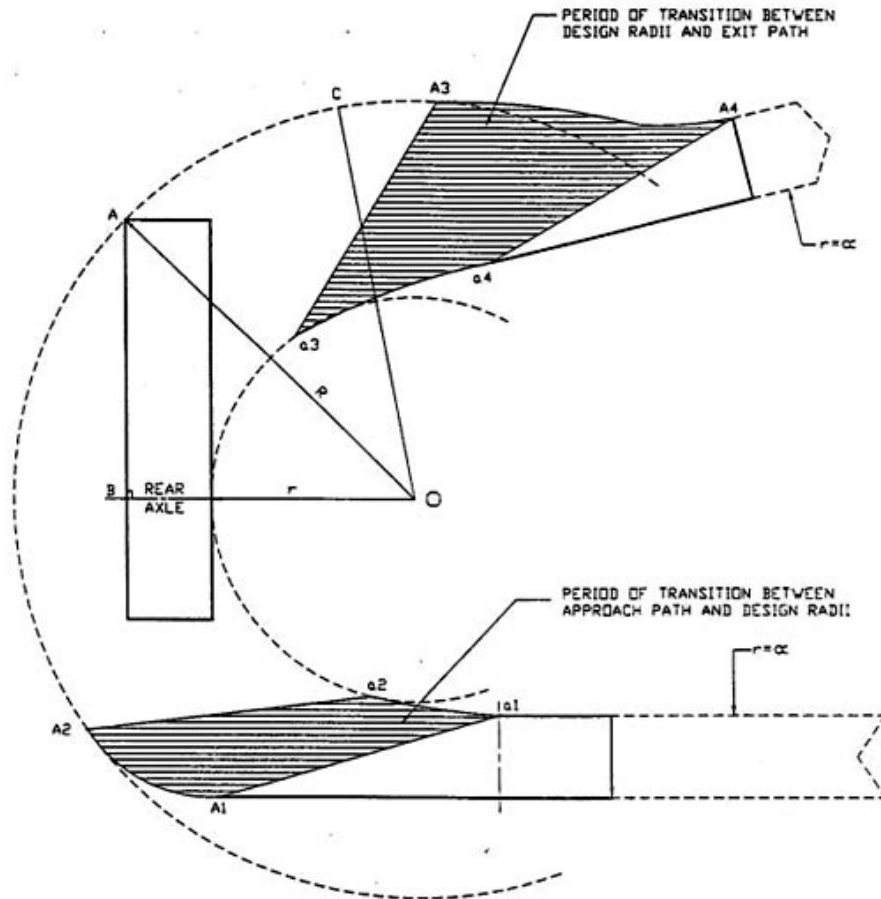

DIAGRAM 2.3.2.3: COMPONENTS OF SWEEP PATH FOR 90° TURN



- O = CENTRE OF SWEEP PATH RADII
- R = EXTERNAL RADIUS OF BUS BODY
- r = INTERNAL RADIUS OF BUS BODY
- POINT 'a' = POINT ON BUS BODY THAT DESCRIBES INTERNAL RADIUS 'r'
- i.e. EDGE OF REAR AXLE
- POINT 'A' = POINT ON BUS BODY THAT DESCRIBES EXTERNAL RADIUS 'R'
i.e. FRONT EXTERNAL CORNER
- BUS 1 = POSITION OF APPROACHING BUS ON ZERO LOCK IMMEDIATELY
PRIOR TO APPLICATION OF LOCK
- BUS 2 = POSITION AT WHICH TURNING BUS ATTAINS DESIRED DESIGN
LOCK
- BUS 3 = POSITION OF BUS AT WHICH REMOVAL OF DESIGN LOCK
COMMENCES
- BUS 4 = POSITION OF BUS AT WHICH ZERO LOCK IS RESUMED

DIAGRAM 2.3.2.4: CALCULATION OF THE VALUE OF INTERNAL AND EXTERNAL RADIUS OF THE SWEEPED PATH



$(A2/A3 - a2/a3)$ = PERIOD DURING WHICH RIGID P.S.V. IS ON DESIGN RADII 'R' & 'r'

OPPOSITE AB = (WHEELBASE + FRONT OVERHANG)

BASE BO = (INTERNAL RADIUS 'r' + 2.5m)

BY PYTHAGORAS,
HYPOTENUSE (EXTERNAL RADIUS R) $AO = \sqrt{(AB^2 + BO^2)}$

DIAGRAM 2.3.2.5: DISTANCE REQUIRED TO PULL ADJACENT TO THE KERBLINE

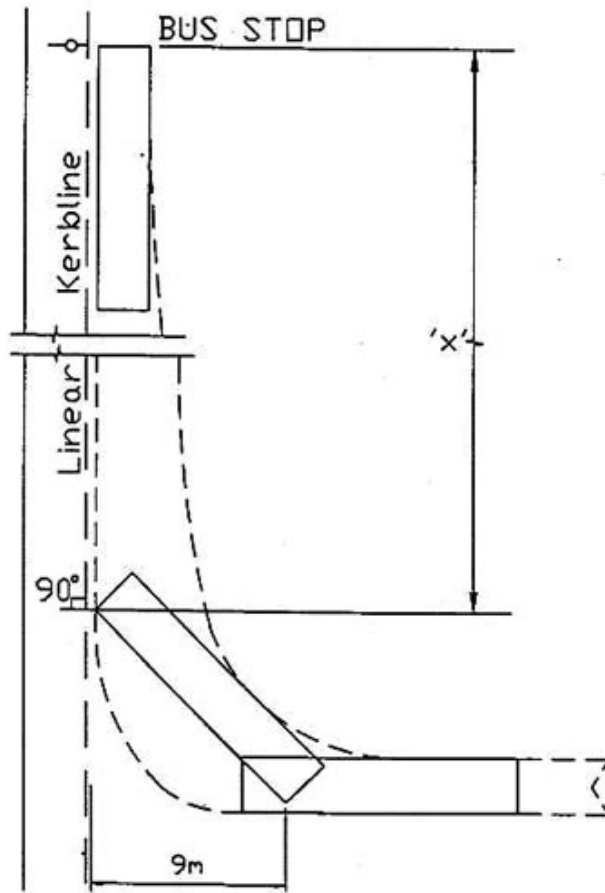
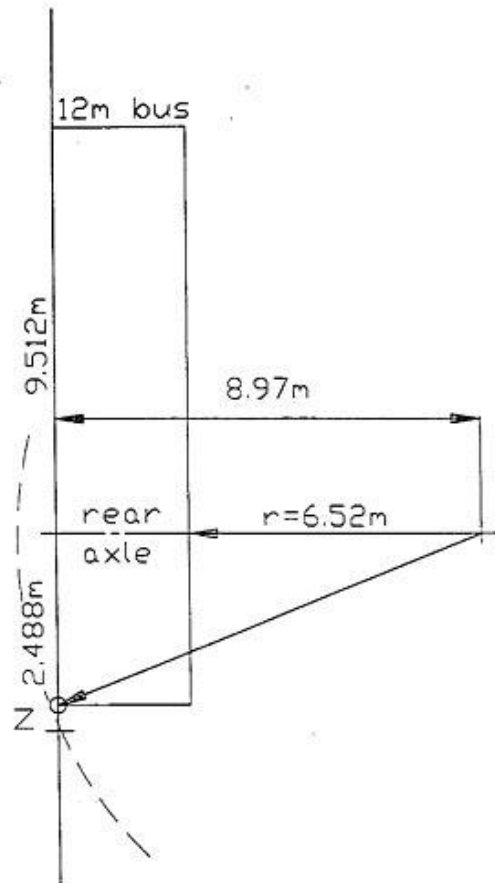

DIAGRAM 2.3.2.6: SWEEPED PATH OF REAR OVERHANG

advance. Similarly, point "a" forms a tangent (point "a2") with the design radius "r", and appears to move a maximum of 0.5m in a sideways direction to establish this point.

- 2.3.2.8 As these 2-dimensional movements appertain to not only the longest permissible rigid franchised bus but also to full lock for that vehicle, it is reasonable to assure that they represent the maxima. Therefore, as the design radii increase, and assuming that the rate of application of the lock remains constant, the transition period times and distances travelled will decrease, although the reduction in the distances travelled forward will not be as great as the reduction in the sideways direction, as the approach speed is likely to increase as the turn radius increase.
- 2.3.2.9 Based upon the foregoing, the centre of any design radii may, to an acceptable degree of accuracy, be established in relation to a predetermined approach path, or, conversely, the approach path and point of turn (position 1) may be established in relation to predetermined design radii.
- 2.3.2.10 The use of the 5m offset to relate the front, inside corner of the approach bus at the point of turn to the outer design radius "R" should serve as a guide only, as the distance will in fact vary with such factors as approach speed and rate of application of lock. However, regardless of the dimension quoted, the greater the design radii, the shorter are the transition periods and distances required, and therefore the closer the outer design radius "R" will come to the front external corner of the design bus. However at no time will any point on this radius fall within the plan area of the design bus.
- 2.3.2.11 Similarly, the greater the design radii, the closer the internal design radius "r" will approach to the inside bodyline of the design bus, but that, at no time, will any point on this radius fall within the plan area of the design bus, nor, at any time, will the centre of curvature of the design radii fall behind the line of the rear axle produced.
- 2.3.2.12 When the exit path transition period is studied, it will be seen that when the design lock is released comparatively quickly in order for the bus to adopt an exit path parallel to a tangent line from internal radius 'r' (as shown in Diagrams 2.3.2.3 and 2.3.2.4) point 'a' again moves some 0.5m in a sideways direction from

this tangent line, and the bus requires a forward distance of at least 12m measured from radial CO laying at 90° to the exit path, before zero lock can again be realised. Again, these figures can be regarded as maxima, and again the exit path can be established in relation to a predetermined design lock, or a swept path may be defined in relation to a fixed bus position, such as buses reversing.

- 2.3.2.13 Alternatively, the bus may be required to adopt a stand position as close as possible to, and parallel to (for the convenience buses with centre-exit doors) a linear kerbline running parallel to a tangent line to the outer radius 'R'. In this case, the rear of the bus must move across some 9m (for a 12m vehicle) between the positions at which the release of the design lock begin and that at which the prescribed parking position is achieved. At present a value of 24m for the distance 'X' in Diagram 2.3.2.5, is used although this has yet to be seen verified under test conditions.
- 2.3.2.14 The swept path of rear overhang can be derived by similar calculation, the radius described by the outer corner of the rear overhang being 9.31m when within design radii and on full lock. The maximum sideways movement is therefore 341mm. However, when a 12m bus is pulling away from a straight kerbline on full lock, point 'Z' (Diagram 2.3.2.6) is describing the transition from zero to full lock and related tests showed that the maximum depth of this swept area over the adjacent kerb was only 50% to 60% of the calculated value.
- 2.3.2.15 The preceding data is based upon test results obtained by comparatively experienced drivers under ideal test conditions, and due allowance must therefore be made for actual site conditions, such as gradients, cambers, actual traffic conditions, driver experience and expertise, approach and manoeuvre speed, rate of application of lock, tyre slip, and weather conditions.
- 2.3.2.16 The test results appear to verify the accepted principle that the rear axle always lies on a radial to the centre of curvature, and this principle forms the basis for both the analysis and construction of swept paths. The function of the front axle has been ignored as this has virtually no influence upon the formation of swept paths, particularly when located conventionally along the chassis, and any extremes in wheelbase length would only affect the full-lock performance figures for the individual vehicle under consideration.
- 2.3.2.17 Whilst it is accepted that vehicle manoeuvres are only rarely executed by adopting a single lock, except by the most experienced drivers, and that manoeuvres are more likely to be completed in a series of constantly adjusted locks, it is also accepted that the various test results from different sources are representative of both methods of execution, and that the accuracy of the analysis is not prejudiced.
- 2.3.2.18 The swept path described by body points 'A' and 'a' have been adopted for design purposes to ensure that no areas of pedestrian activity are swept by the front, or rear, body overhangs of the vehicle, that possible damage to both vehicle and property is avoid, and that the swept paths of buses do not conflict with those of other traffic.

2.3.3 Methods for Calculating Swept Paths

- 2.3.3.1 The basic principles derived from the test results described in section 2.3.2 have been used to form the basis of the methodology for calculating swept paths.
- 2.3.3.2 The following examples serve to illustrate the methods employed in constructing swept paths for any turns, and which coupled with the previous information regarding exit transitions, produce the swept paths for the various elements of comparatively complex manoeuvres.

2.3.3.3 Whilst the designer is almost invariably required to take full advantage of the manoeuvring capabilities of the design vehicle, the use of turns involving full lock should be avoided wherever possible as, whilst physically possible to achieve, this relies more upon the expertise of the driver, and such turns may not always be regarded as feasible by those required to perform them, particularly when it is necessary to do so many times each day.

2.3.3.4 The examples below are two-dimensional only and no allowance has been made for the effect of gradients or adverse cambers.

2.3.3.5 In the following examples, a 12m long bus has been used as the design vehicle (Diagram 2.3.3.1), but the procedure is applicable to any conventional, rigid bus of any size.

2.3.3.6 Calculation of a left (or right) hand turn around a predetermined internal kerb radius is determined by taking in this case an internal kerb radius of 11m, with a 90 degree angle of turn. The swept path may now be established in the following manner (see also Diagram 2.3.3.2) :

- (i) The internal design radius ' r ' is established on the assumption that 1.0m minimum clearance is required between the inside of the bus and the inside kerb radius, $r=11+1=12$. From section 2.3.2 and Diagrams 2.3.2.3, and 2.3.2.4 the base of the "Design-Lock" triangle radius = $r + 2.5m = 14.5m$, and $R = \sqrt{(14.5^2 + 9.512^2)}m = 17.34m$.
- (ii) Diagrams 2.3.2.3 and 2.3.2.4 the maximum sideways movement for a 12m bus on full lock is 0.5m, and it is therefore reasonable to assume that for a shorter bus on a greater design lock, a figure of 0.3m is reasonable. The approach path may therefore be added by drawing 2 lines parallel to the approach kerblines and 0.5m and 3.0m from a line tangential to radius 'r'.
- (iii) If the inside body line of the approach path is produced to intersect with radius 'R', the front face, rear axle, and rear end of the approach bus may be established by using the approximate dimension of 5m from Diagrams 2.3.2.3 and 2.3.2.4 thus determining the position of the approach bus immediately prior to application of lock.
- (iv) The entry transition curves may now be added by using an elliptical curve to join the tangent point at the front outside corner of the bus body to the tangent point to radius 'R' in the vicinity of the centreline of the bus, produced to radius 'R', and by using a circular curve to join the tangent point at the inside bodyline/rear axle intersection, to the common tangent point on radius 'r'.
- (v) In similar manner to the entry path, the departure path, (Diagram 2.3.3.3) may be drawn, and the position of the bus at resumption of zero lock established in relation to the normal from the centre of curvature, depending upon whether the departure path is tangential to

DIAGRAM 2.3.3.1: DESIGN FOR WORKED EXAMPLE - 12 metre bus

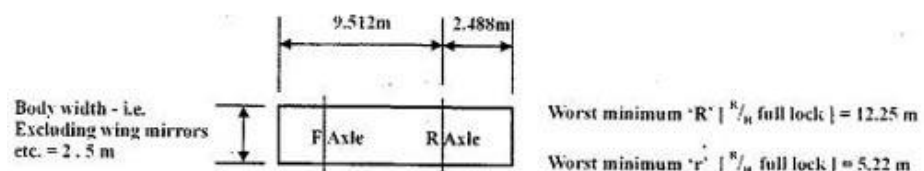

DIAGRAM 2.3.3.2: CONSTRUCTION OF SWEEP PATH - ENTRY TRANSITION

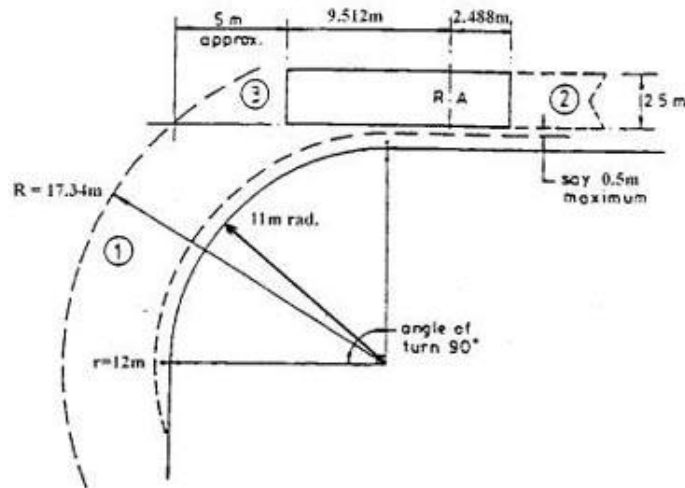
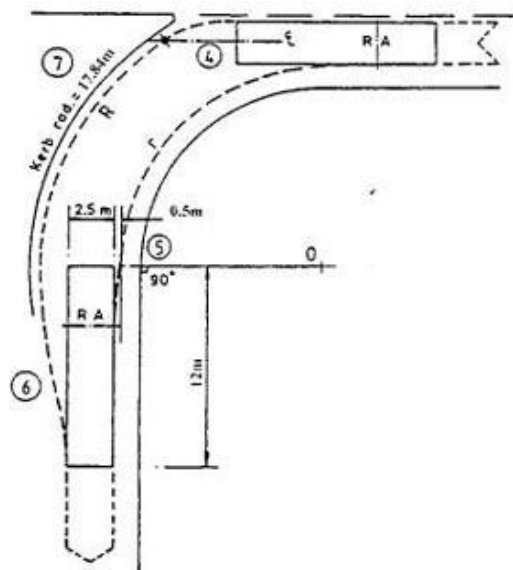

DIAGRAM 2.3.3.3: CONSTRUCTION OF SWEEP PATH - EXIT TRANSITION



outer radius 'R', or, as shown in Diagram 2.3.3.3 to inner radius 'r'.

- (vi) The exit transition curves can now be added using circular curves to join the common tangent points on radii R and r, to the tangent points at the outside front corner and inside bodyline/rear axle intersection respectively.
- (vii) Assuming a minimum clearance of 0.5m between the outer radius R and the outside kerb, the radius of the outside kerb = $(17.35 + 0.5)m = 17.85m$ or, say, 18m. The width of the swept path therefore = $(R-r)$ or $(17.35 - 12)m = 5.35m$, and the lane width = $(18 - 11)m = 7m$.

2.3.3.7 It should be remembered at this stage that the above results are for the ideal conditions only, and should therefore be regarded as absolute minimum.

2.3.3.8 The above examples demonstrate the basic principle of bus carriageway design, that the driver should only be obliged to follow the outside kerb radius with the front, outside corner of the vehicle. If the carriageway is correctly designed, the inside extremity of the bus will then follow at a safe distance from the inner kerb.

2.3.3.9 It should also be noted that this turn across an adjacent kerbline produces the widest breach in that kerbline, (approx. 0.5m along the kerb edge in the above example), resulting in excessive pedestrian crossing lengths where the footpath runs at the kerb edge. Preferably, footpaths should be therefore be set back as far as possible from the kerbline so that the crossing length is reduced to the minimum, or even cranked to cross the bus carriageway as a radial to the centre of curvature, that is the 7 m lane width in the above example.

2.3.3.10 The above example also assumes that both the approach and departure traffic lanes are a minimum width of 4m, the outside bodyline being 3.5m from both the approach and departure kerblines, when, in practice, this is unlikely to be the case. In addition, when the approach and departure traffic lanes are narrower there can be a tendency on the part of the bus driver on the approaching turn to ease the manoeuvre by moving away from the adjacent kerbline, and, in doing so, possibly affecting traffic in the adjacent lane. In order to overcome this, a compound curve for the internal kerbline may be introduced (Diagram 2.3.3.4). The compound radius curve internal kerbline has a further advantage in that the kerbline is more closely related to the shape of the actual swept path.

2.3.3.11 Calculation of a right or left hand turn within a predetermined external kerb radius is determined by in this case taking an example whereby a bus carriageway is required from a 4m wide approach lane in relation to a 25m external radius formed by one edge of a splitter island, (Diagram 2.3.3.5).

- (i) Allowing 0.5m clearance from the 25m radius to the external bus radius, R is therefore 24.5m. From Diagrams 2.3.2.3 and 2.3.2.4.

$$R = \sqrt{\text{Base}^2 + 9.512^2} \text{m}$$
 or Base, $B = \sqrt{(R^2 - 9.512^2)} \text{m} = \sqrt{(600.25 - 90.478)} \text{m} = \sqrt{509.772} \text{m} = 22.5 \text{m}$
 then radius $r = B - 2.5 \text{m} = 20 \text{m}$
- (ii) Allowing a clearance of 1m between the internal radius r and the inside kerb (or traffic lane) radius, the latter therefore becomes 19m.

DIAGRAM 2.3.3.4: COMPOUND RADIUS CURVE

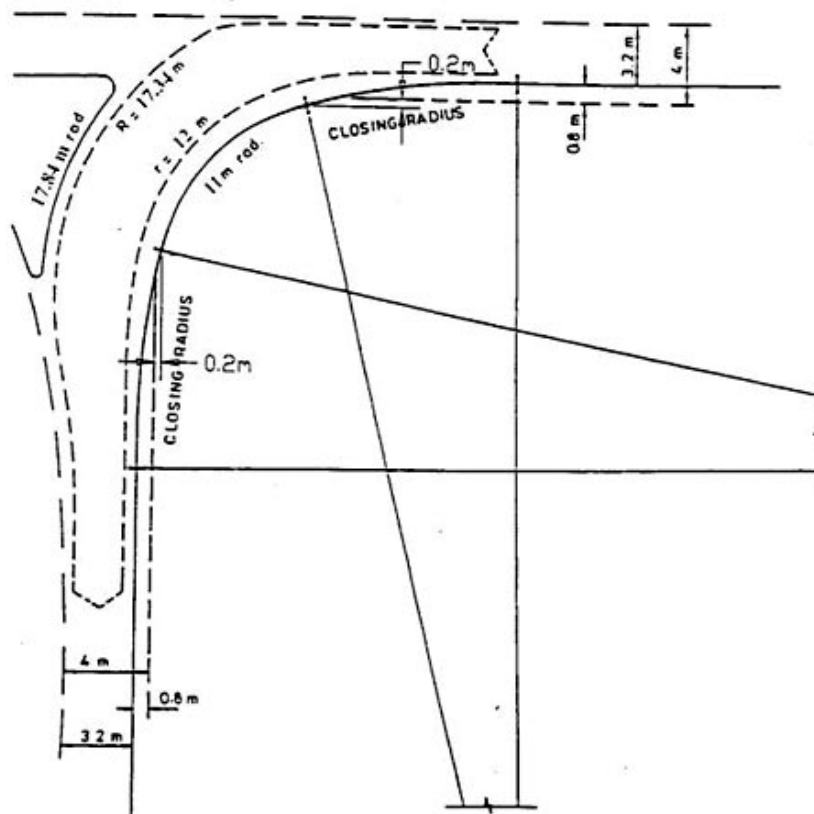
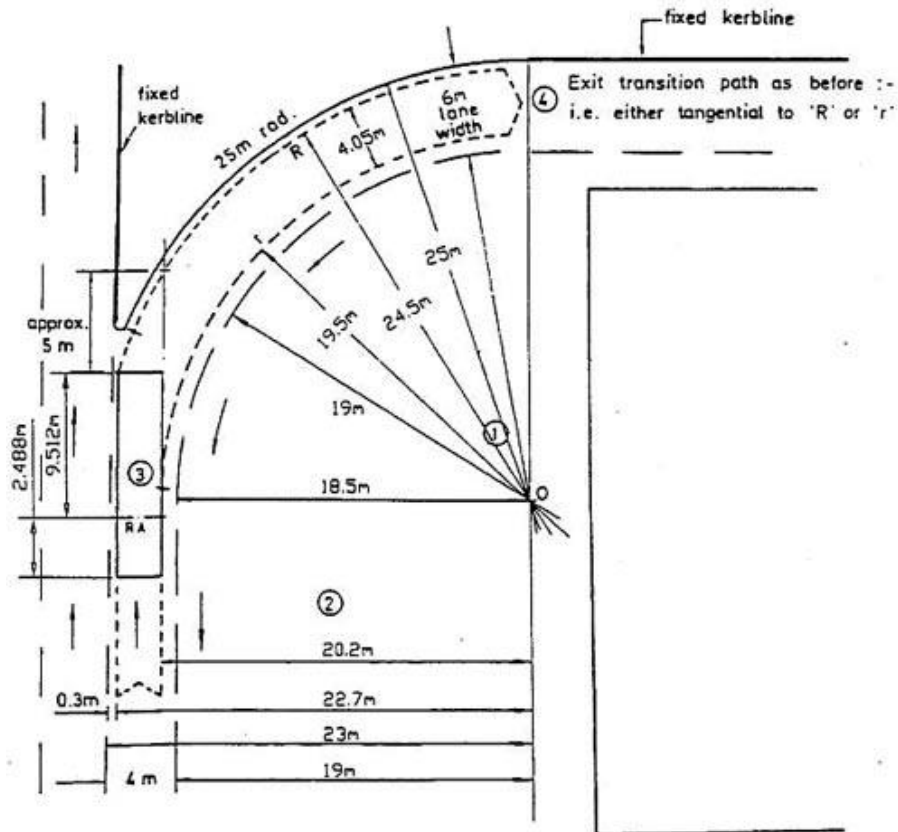

DIAGRAM 2.3.3.5: CONSTRUCTION OF SWEEP PATH PREDETERMINED EXTERNAL RADIUS



- (iii) The centre of curvature therefore lies on a line parallel to and 23m from the lane marking between the through lane and the turn lane. Allowing 0.2m sideways movement during the entry transition period would provide an acceptable clearance of 0.3m between the outside bodyline and the lane line.
- (iv) The approach path having been established, the position of the bus at the point of turn can be plotted, and the appropriate transition curves added.
- (v) The exit transition path, as before, can be determined dependent upon whether it is tangential to the design radius 'R' or 'r'.

2.3.3.12 The definition of swept paths in relation to an external kerbline is not only useful for the foregoing situation, but also for relating swept paths to the centreline of a road bend (i.e. for buses moving in the opposite direction to the bus in the example), and for establishing the degree of widening necessary on bends on bus roads.

2.3.3.13 The detailed design of bus only roads and within bus termini is therefore possible and using the preceding information, the swept paths of complex manoeuvres can be drawn by detailed each component of the manoeuvre, one such example being shown in Diagram 2.3.3.6.

2.3.3.14 These series of complex manoeuvres have the following elements:

- (i) A left-hand turn around a compound internal curve, to ease the relationship between the swept path and a narrow approach lane, plus an exit path tangential to "R" to allow access to a narrow departure lane without sweeping over the centreline of the road.
- (ii) A right-hand turn through 90° showing a narrower mouth of opening required when some of the manoeuvre can be absorbed by the existing highway width.
- (iii) A right-hand turn within an external curve, and with an exit path tangential to "R" to facilitate

an approach to a linear bus stand.

- (iv) A right and left-hand reverse-curve turn from bus stand to an out-of-service bus park, both turns approaching full lock and exit paths tangential to radius 'r' and showing the point ('x') at which the path described by the front nearside corner of bus 4B is replaced by the path of the rear axle/nearside bodyline point of bus 4C.

DIAGRAM 2.3.3.6: EXAMPLE OF COMPLEX MANOEUVRES

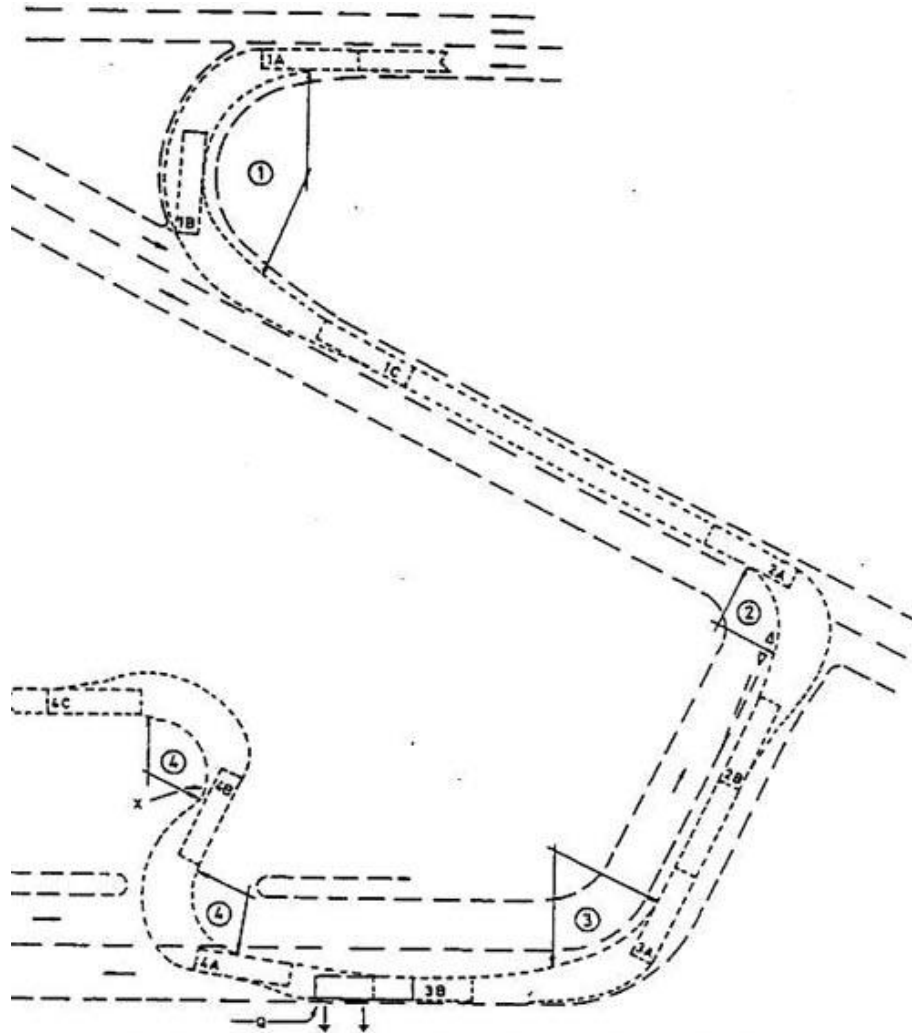

2.3.3.15 As indicated above, it is possible to calculate the value of both inner and outer swept path radii. This has been worked through for various bus types and the results are shown in Table 2.3.3.1. These results have been utilised to devise the requirements for basic carriageway widths within bus termini, and they are shown in Table 2.3.3.2. Ranges of overall measurements for various bus types are shown in Table 2.3.3.3. It should be noted that definition of the effective wheelbase used in the calculation of swept paths is different for 3 axle buses as opposed to 2 axle buses, and within the 3 axle buses themselves there are different means of measuring the effective wheelbase. For example:

- (i) The distance between the leading axle and the mid-point between the second and third axles for buses with rigid second and third axles, such as the Dennis Dragon and Dennis Trident.
- (ii) The distance between the leading axle and the second axle for buses with a steerable third axle, such as the 12 metres Neoplan Centroliner.
- (iii) The distance between the leading axle and the third axle for buses with a self-steering second axle, such as the Volvo Olympian and the Leyland Olympian.

2.3.3.16 These basic differences have a significant impact on the overall space requirements of each vehicle type. In particular, the Leyland or Volvo Olympian 3-axle configuration produce substantial swept path width

differences because of its very large effective wheelbase (7.2 metres). The Dennis Dragon and Trident only have an effective wheelbase of 6.457m and 6.45m respectively.

2.3.3.17 An alternative method of calculating the swept path of vehicles has been outlined in Volume 2, Chapter 2 and is known as the Schneider Method. However, the principles outlined in this section equally apply and either method may be used.

Table 2.3.3.1 Widths of Swept Paths for Five Popularly used 12m Buses

Internal Radius of Bus (r) (metres)	Width of Swept Path (metres)				
	12m buses				
	Leyland / Volvo Olympian	Dennis Dragon	Dennis Trident	Trident Alexander	MAN
6.0	N/A*	N/A*	6.27	6.28	6.13
7.5	6.27	5.83	5.85	5.86	5.72
9.0	5.89	5.49	5.51	5.52	5.39
10.0	5.67	5.29	5.32	5.32	5.20
12.0	5.30	4.96	4.99	4.99	4.88
15.0	4.87	4.58	4.61	4.62	4.51
20.0	4.38	4.15	4.18	4.18	4.10
25.0	4.05	3.86	3.89	3.89	3.82
30.0	3.82	3.65	3.68	3.69	3.62
35.0	3.64	3.50	3.53	3.53	3.47
40.0	3.50	3.38	3.41	3.41	3.36
45.0	3.39	3.28	3.32	3.32	3.27
50.0	3.31	3.21	3.24	3.24	3.20
100.0	2.95**	2.97**	3.00**	3.00**	2.99**
150.0	2.95**	2.97**	3.00**	3.00**	2.99**
Straight	2.95**	2.97**	3.00**	3.00**	2.99**

Notes:

There are small variations in basic measurements depending upon the bodywork fitted.

* Swept path width + r should be greater than or equal to the minimum outer swept circle.

** Bus width plus 500mm for side mirror allowance should be used when the calculated swept path width is smaller.

Table 2.3.3.2
Minimum Lane Widths on Bends in Bus Termini

Internal Kerb Radius (metres)	Single (2) Lane (metres)	Double (2) Lane One or Two
10	6.6	11.0
15	5.8	10.3
20	5.4	9.5
25	5.1	9.0
30	4.8	8.7
40	4.5	8.5
50	4.3	7.9
100	3.9	7.3
150	3.7	7.0
Straight (1)	3.5	6.75

Notes:

- (1) Lane widths on the straight relate to linear bus termini shallow sawtooth widths are greater
(2) Lane widths are for bus termini which are exclusively used by buses.

Table 2.3.3.3 Data for Various Bus Types

KMB

Double Deck Non A/C											
	Dennis Jubliant	Dennis Dominator	Leyland Olympian 9.5m	MC W 9.7m	Mercedes Benz	Leyland Olympian 11m	MC W 11m	Dennis Dragon 11m	Leyland Olympian 12m	Dennis Dragon 12m	Volvo Olympian 11m
Body Width (mm)	2,500	2,500	2,500	2,500	2,500	2,500	2,500	2,500	2,500	2,500	2,500
Front Overhang (m)	2,044	2,248	2,312	2,260	2,400	2,312	2,270	2,245	2,312	1,900	2,352
Rear Overhang (m)	2,725	2,286	2,350	2,410	3,064	3,150	3,280	3,086	3,150	3,822	3,110
Wheelbase (mm)	4,800	4,953	4,953	4,950	5,600	5,700	5,450	5,659	6,454	6,278	5,700
Body Length (mm)	9,652	9,487	9,615	9,700	11,064	11,320	11,000	11,030	12,000	12,000	11,162
Height (mm)	4,496	4,369	4,385	4,375	4,478	4,360	4,350	4,375	4,376	4,360	4,500
Outer Swept Circle (m)	20.65	22.7	19.95	19.57	21.25	22.54	23.9	23.85	24.95	25.4	22.8
GVW (kg)	16,000	16,260	16,260	16,260	16,260	22,090	21,330	21,581	22,250	21,300	23,500
Power (kw)	127	127	127	127	179	164	164	164	164	164	186

KMB (continued)

											Single Deck			
	Dennis Dragon 10m	Dennis Dragon 11m	Dennis Dragon 12m	Dennis Trident 12m	Scania 11m	Volvo Olympain 11m	Volvo Olympain 12m	Neoplan Centroliner 12m	Dennis Trident 10.6m	Volvo Super Olympian 12m	Mitsubishi	Dennis Dart 10m	Dennis Lance	Dennis Falcon Coach
Body Width (mm)	2,500	2,500	2,500	2,500	2,500	2,500	2,500	2,500	2,500	2,500	2,300	2,400	2,500	2,440
Front Overhang (m)	1,940	2,265	2,265	2,414	2,312	2,312	2,312	2,600	2,400	2,354	1,850	2,210	2,611	2,255
Rear Overhang (m)	2,986	2,986	3,030	3,040	3,520	3,170	3,070	3,410	3,050	3,050	2,750	2,635	2,980	3,383
Wheelbase (mm)	4,917	5,459	6,459	6,450	5,710	5,700	6,400	5,990	5,135	6,490	4,590	5,115	5,950	5,639
Body Length (mm)	9,988	10,990	11,835	11,984	11,620	11,350	11,978	12,000	10,685	12,000	9,150	10,030	11,652	11,277
Height (mm)	4,369	4,369	4,400	4,382	4,480	4,300	4,420	4,300	4,400	4,366	2,950	3,025	2,952	3,200
Outer Swept Circle (m)	21.3	23.9	24.9	22.5	24.5	22.7	25.25	19.8	19	25.7	18.45	19.8	22.5	23.4
GVW (kg)	23,000	21,800	23,000	23,500	23,400	23,500	23,500	24,000	23,500	23,300	10,200	10,000	16,800	11,277
Power kws	191	188	191	224	180	180	180	224	224	210	134	108	157	164

CITYBUS

	Double Deck											Single Deck			
	Leyland Olympian 10.4m	Leyland Olympian 12m	Volvo Olympian 10.4m	Volvo Olympian 11m	Volvo Olympian 12m	Volvo Plaxton 12m	Dennis Dragon 10.4m	Dennis Dragon 12m	Dennis Trident 10.6m	Dennis Trident Duple 12m	Trident Alexander 12m	MAN 12m	Volvo B6LE Plaxton	Volvo B6LE Jit Luen	MAN NL262
Body Width (mm)	2,450	2,450	2,450	2,450	2,450	2,500	2,465	2,465	2,500	2,500	2,500	2,485	2,420	2,440	2,500
Front Overhang (m)	2,312	2,312	2,312	2,312	2,312	2,319	2,402	2,402	2,400	2,400	2,414	2,590	2,375	2,420	2,430
Rear Overhang (m)	2,350	2,350	2,350	2,350	2,350	2,468	2,286	2,286	2,400	2,400	2,378	2,560	2,830	2,900	3,270
Wheelbase (mm)	4,200 +1,600	5,600 +1,600	4,200 +1,600	4,900 +1,600	5,600 +1,600	5,600 +1,600	4,117 +1,600	5,657 +1,600	4,385 +1,500	5,700 +1,500	5,700 +1,500	5,400 +1,350	5,315	5,315	5,875
Body Length (mm)	10,448	11,978	10,448	11,300	11,978	11,987	10,405	11,947	10,685	12,000	11,984	12,000	10,520	10,635	11,750
Height (mm)	4,376	4,376	4,376	4,376	4,376	4,384	4,375	4,375	4,400	4,382	4,382	4,447	2,980	2,830	3,000
Outer Swept Circle (m)	21.5	25.95	21.65	22.1	24.5	23	22.1	25.75	20.3	23.4	22.85	22.5	23	22	23
GVW (kg)	21,250	22,250	21,250	22,940	22,250	22,940	23,500	23,500	23,500	23,100	23,100	21,450	11,800	11,800	16,000
Power (kw)	188	188	180	180	180	180	188	188	224	224	224	275	154	154	191

New World First Bus

	Double Deck									Single Deck		
	Leyland Olympian	Volvo Olympian	Dennis Condor	Dennis Trident 12M	Dennis Trident 11.3M	Dennis Trident 10.6M	Dennis Trident 12M	Dennis Trident 10.3M	Volvo Super Olympian	Dennis Dart	Dennis SLF Dart 10.7M	Dennis SLF Dart 10.1M
Body Width (mm)	2,450	2,480	2,500	2,470	2,500	2,500	2,500	2,500	2,480	2,300	2,400	2,400
Front Overhang (m)												
Rear Overhang (m)	2,350	3,170	3,000	3,050	3,035	3,035	3,050	3,050	3,160	2,600	2,610	2,611
Wheelbase (mm)	6,500	6,500	6,459	7,200	6,473	5,885	7,200	5,885	7,200	5,115	5,800	5,200
Body Length (mm)	11,162	11,300	11,035	11,984	11,272	10,679	12,000	10,385	12,000	9,800	10,736	10,131
Height (mm)	4,370	4,382	4,370	4,382	4,382	4,382	4,400	4,170	4,380	2,910	2,980	2,980
Outer Swept Circle (m)	22	22.7	25.4	23.1	23.9	20.35	23.1	19.04	24.6	21	22	20.55
GVW (kg)	22,250	22,940	23,000	23,500	23,500	23,500	23,500	23,500	22,940	10,000	12,000	12,000
Power (kws)	180	180	188	224	224	224	224	224	180	107	107	107

2.3.4 Standard Design Bus for Hong Kong

2.3.4.1 In Hong Kong, bus fleet from different franchised operators is highly varied in nature. The choice of the design bus taken in any given circumstance is dependent on the function and the lifespan of the project under consideration. It is most sensible if the largest possible vehicle is adopted as a standard bus design even though it may only form a small proportion of the fleet at the time of design. The obvious advantages are that the design bus can be accommodated if required in the future, and that in the interim, shorter buses which use the scheme will find the design marginally more comfortable to negotiate.

2.3.4.2 The design bus will not simply conform to the largest in operation at any given time, as variations in fleet mix will produce different dimensions with regards to type, length and door openings. Any proposed scheme should be designed to cater for the worst case and may involve a combination of elements, which are not necessarily found in one vehicle. Additionally, as new facilities are liable to have a projected life of 30 years or more, some estimation as to future changes in vehicle design should be made.

2.3.5 Standard Dimensions and Clearances

2.3.5.1 Standard dimensions and clearances for the design bus are shown in Diagrams 2.3.5.1 and 2.3.5.2 for 2-axle and 3-axle buses respectively. Overall dimensions are based on permitted maxima in the Road Traffic (Construction and Use) Regulations, Cap. 374. Where the regulations specify minima and actual practice is in excess of this, the more typical measurement is shown. If there is no statutory dimension, typical measurements are again taken. Whilst the Regulations permit the operation of 15 metre articulated buses these are restricted to single deck vehicles and it is felt that their overall capacity is not liable to be considerably more than that obtained by the 3-axle bus. Further, the 15 metre standard in the Regulations does not conform to the international standard length of 18 metres. The 3-axle bus has therefore been taken as the standard design maxima for Hong Kong.

2.3.5.2 The maximum dimensions and clearances shown in Diagrams 2.3.5.1 and 2.3.5.2 comprise the following elements :

- (i) Maximum length for rigid PSV = 12 metres
- (ii) Maximum width for rigid PSV = 2.5 metres (excluding wing mirrors)
- (iii) Maximum height for rigid PSV = 4.6 metres
- (iv) Minimum height clearance on = 5.1 metres on public roads
(For bus termini which form part of multi storey developments, a greater clearance is required. A height of 6m is a desirable minimum after taking into account the installation of lighting and mechanical ventilation system.)
- (v) Maximum overhang = 60% of the length defined in the Road Traffic (Construction & Maintenance) Regulations, roughly the effective wheelbase.
Minimum wheelbase (when both overhangs are equal)
= $((100/220) \times 12 \text{ m}) = 0.455 \times 12 \text{ m} = 5.46 \text{ m}$
Therefore each overhang = 3.27 m
Maximum overhang (i.e. only 1 overhang)
= $((100/160) \times 12 \text{ m}) = 0.6251 \times 12 \text{ m} = 7.5 \text{ m}$
Therefore overhang = 4.5 m
(In practice, the overhangs will vary according to the wheelbase and typical clearances are shown in Diagrams 2.3.5.1 and 2.3.5.2.)
- (vi) Kerb Height: a maximum of 200 mm, to avoid possible damage to the body skirt, with a minimum of 150 mm.
- (vii) Kerb Zone Clearance: generally 0.5 m, but subject to conditions laid down.

(viii) Minimum lane width between kerbs on the straight = 3.5 metres (minimum)

2.3.5.3 The clearances required through any opening (bridge, bus garage, terminus) are shown in Diagram 2.3.5.3. This is intended as a guide only and the dimensions given apply to openings to be negotiated by buses travelling on a straight path. Turning movements on the approach or departure sides of openings can greatly influence the width required, as indicated in Diagram 2.3.5.3.

DIAGRAM 2.3.5.1: BODY PROFILE FOR THE DESIGN 2 AXLE BUS
SCALE:1:100

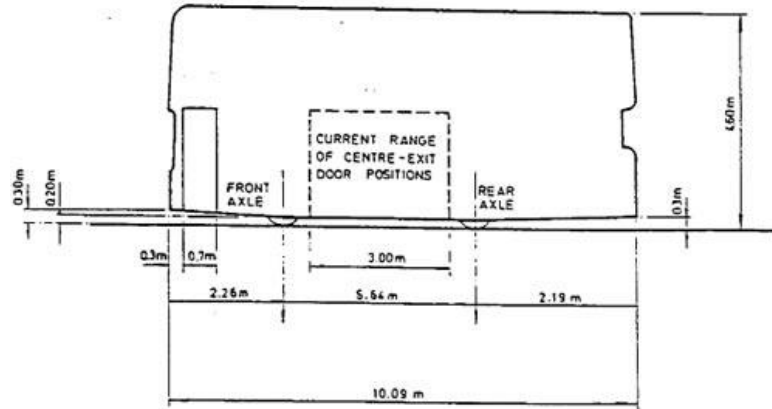
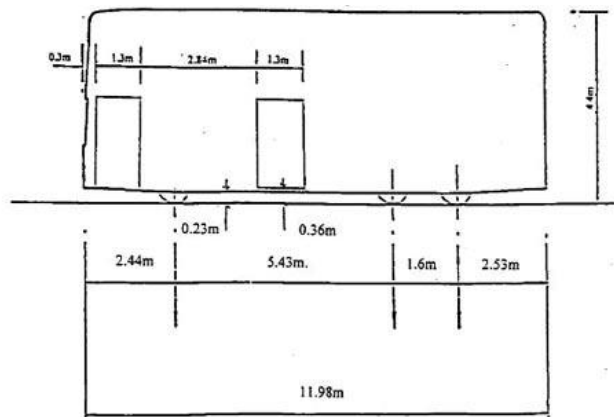
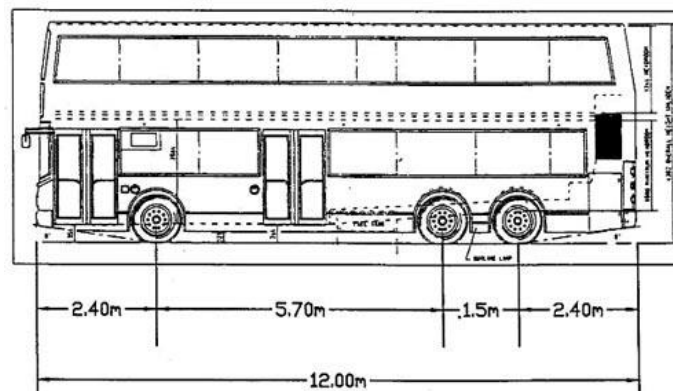

DIAGRAM 2.3.5.2: BODY PROFILE FOR THE DESIGN 3 AXLE BUS



NOTES: THE MAJORITY OF MEASUREMENTS ARE TAKEN FROM THE LEYLAND OLYMPIAN USED BY KMB.



Notes: THE MAJORITY OF MEASUREMENTS ARE TAKEN FROM THE DENNIS TRIDENT 12m

DIAGRAM 2.3.5.3: GUIDELINES FOR ENTRANCE/EXIT OPENINGS

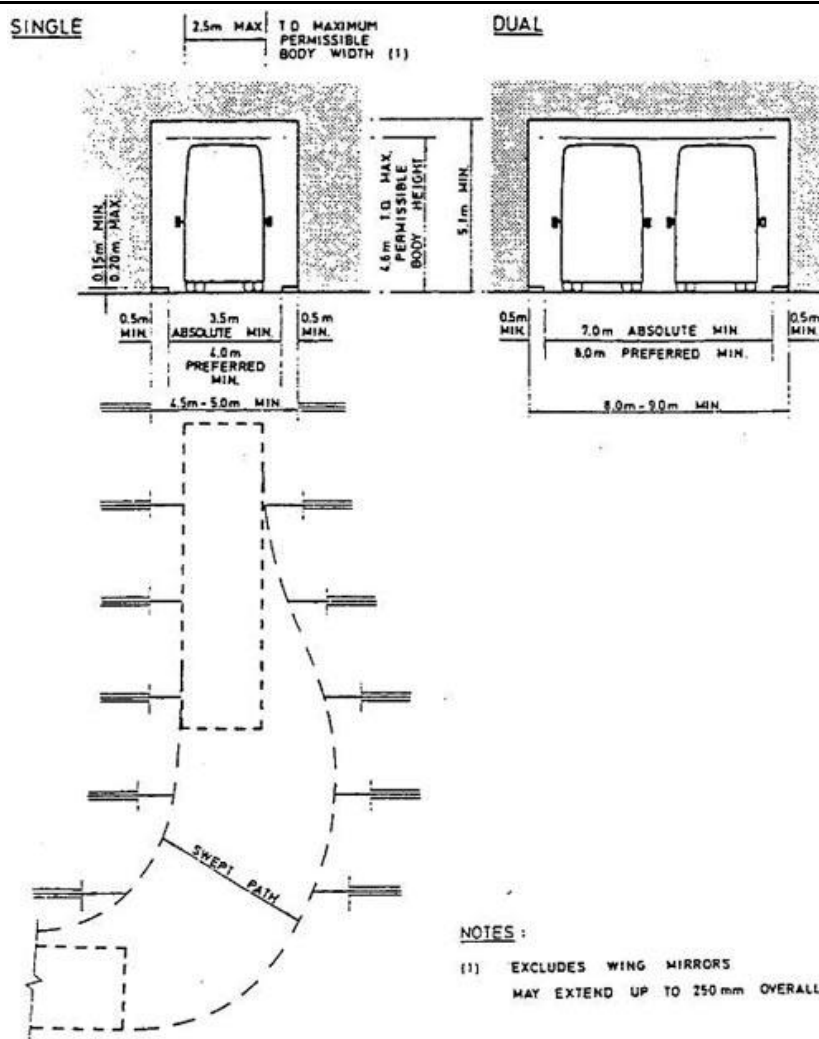

2.3.6 Fleet Composition and Body Types

2.3.6.1 By the end of December 1999, the licensed fleets* of the major franchised bus companies including KMB, Citybus and NWFB were composed of the following vehicles:

Table 2.3.6.1 Fleet Composition (as at 31 December 1999)

	KMB		Citybus		NWFB	
	No.	%	No.	%	No.	%
(i) Single Deck Buses	265	6.5	128	13.3	96	13.3
(ii) Double Deck Buses						
- 2 axle	282	6.9	N/A	N/A	N/A	N/A
- 3 axle	3,532	86.6	832	86.7	609	86.7
Total	4,079	100	960	100.0	705	100.0

* including those temporarily de-licensed.

2.3.6.2 On the basis of the above information, it can be seen that majority of the bus companies deploy 3 axle double deck buses. The most popular vehicle type are the Volvo Olympian, Leyland Olympian and Dennis Trident.

2.3.6.3 A similar analysis on the variation in body types, reveals that the majority of buses have front entrance/centre exit configurations, being both suitable for one man bus operation and to increase the flow of boarding and alighting passengers. A breakdown of the body types of the fleet of the major franchised companies is shown in Table 2.3.6.2.

Table 2.3.6.2 Body Types (as at 31 December 1999)

	KMB		Citybus		NWFB	
	No.	%	No.	%	No.	%
(i) Front Entrance / Exit						
-Single Deck Buses			21	2.2	N/A	N/A
- Double Deck Buses	251	6.2	85	8.9	N/A	N/A
(ii) Front Entrance, 2 centre exits within wheelbase						
-Single Deck Buses	N/A	N/A	N/A	N/A	N/A	N/A
- Double Deck Buses	323	7.9	N/A	N/A	N/A	N/A
(iii) Front Entrance,1 centre exit						
-Single Deck Buses			107	11.1	96	13.3
- Double Deck Buses	3,505	85.9	747	77.8	609	86.7
Total	4,079	100.0	960	100.0	705	100.0

2.3.7 Chassis Length

2.3.7.1 A further analysis of the variation in length of chassis of buses of KMB, Citybus and NWFB is shown in Table 2.3.7.1

Table 2.3.7.1 Chassis Length of Buses (as at 31 December 1999)

Chesis length (including bumpers)	S/D Bus	S/D Coach	No. of Buses			Total	%
			D/D Coach	D/D 2 axles	D/D 3 axles		
			2 axles	3 axles	3 axles		
(i) Up to 8 meters	0	0	0	0	0	0	0
(ii) Up to 9 meters	0	0	0	0	0	0	0
(iii) Up to 9.5 meters	182	0	0	159	0	341	5.9
(iv) Up to 9.8 meters	0	0	0	82	0	82	1.4
(v) Up to 10 meters	53	0	0	0	235	288	5
(vi) Up to 10.6 meters	122	0	1	0	124	247	4.3
(vii) Up to 11 meters	0	16	0	41	2165	2222	38.7
(viii) Up to 11.3 meters	42	0	0	0	417	459	8
(ix) Up to 12 meters	74	0	121	0	1910	2105	36.6
Total	473	16	122	282	4851	5744	100

2.3.7.2 Based on the above, it can be seen that majority of vehicle types fall into 3 major categories -- around 11.3 metres (8.0%) 12.0 metres (36.6%) and 11.0 metres (38.7%). Moreover, about 86.6% of which are 3-axle buses.

2.3.8 Bus Weight

- 2.3.8.1 The gross weight of a bus is limited by the vehicle's mechanical design which specifies a maximum permissible weight for each axle, as well as a maximum total vehicle weight (GVW).
- 2.3.8.2 The Road Traffic (Construction and Maintenance of Vehicles) Regulations Cap 374 imposes limitations on the maximum GVW based on vehicle type, number of axles, number of tyres, wheel span, and distance between axles. The bus will therefore be allocated with both a GVW and individual axle weights which must not be exceeded.
- 2.3.8.3 The GVW for 2-axle and 3-axle buses are 16000 kg and 24000 kg respectively. The maximum permitted weight per axle is 11000kg.

2.3.9 Bus Performance

- 2.3.9.1 The typical 3-axle bus is powered by a 10 litre to 12 litre diesel engine rated at between 164KW and 275KW depending on the exact model. The most common models are the 164KW, 188KW and 224KW rating. Typical fuel consumption is 28-56 litres/100 km but this varies considerably with vehicle type, gearing and rear axle ratios, and also with route terrain, loading conditions, maximum speed and frequency of stops.
- 2.3.9.2 The maximum possible speed for buses is in the range 80-100 km/h. However, the Road Traffic Ordinance sets the maximum operating speed of buses at 70 km/h.
- 2.3.9.3 Typical maximum acceleration rates are in the range 0.7 - 0.9 m/sq. sec. which vary with specification and loading conditions. Such rates are lower than for the average private car to take into account the need to allow for standing passengers.

2.3.10 Gradients for Buses

- 2.3.10.1 Although most buses are capable of negotiating far steeper gradients, tests have shown that a figure of 8% should be regarded as the desirable maximum change in gradient from the level that can be comfortably negotiated by the design bus.
- 2.3.10.2 The gradeability of a bus usually refers to the gradient that can be climbed when approached under power, fully loaded and with the engine in a new condition. Naturally, the restart capability is always less than the maximum gradeability, and this figure would be a more suitable guideline for design purposes.
- 2.3.10.3 For KMB, all buses have a gradeability of around 16% and above. The restart gradient for these buses would be in the order of 12%, and when allowances for engine condition are made, the restart gradient should be in the order of 11%. Whereas newer buses tend to have better restart gradient abilities, allowances must be made for differences in individual vehicle performance under fully laden conditions, and it is therefore recommended that a 10% gradient be taken as the absolute maximum design standard.
- 2.3.10.4 It should also be borne in mind that gradients not only require to be climbed, but also descended, and care should be exercised to ensure that any bus has sufficient braking force to permit safe downhill operation.

2.3.11 The Vehicle Design

- 2.3.11.1 There is a very wide range of bus types operating in Hong Kong. The most common vehicle amongst the existing fleet is the 12-metre 3-axle bus. This is taken to be the design bus, and for reasons outlined in paragraph 2.3.3.16 the effective wheelbase of the Volvo Olympian has been adopted to calculate swept paths. The general principle of taking the most extreme of the dimensions of all the various types of 3-axle bus had been used in the derivation of the design bus, and is shown in Diagram 2.3.5.2. The dimensions of a typical Volvo Olympian 12-metre bus are shown in Diagram 2.3.5.2.
- 2.3.11.2 Where a particular road does not permit the operation of these 12-metre 3-axle bus types in the foreseeable future (30 years), secondary design bus of 10 metres can be adopted. The dimension of the 10-metre 2-axle bus is illustrated in Diagram 2.3.5.1.

2.4 Bus Stops

2.4.1 Location

- 2.4.1.1 A bus stop is the place at which an intending passenger gains access to the public transport system, the transition point between pedestrian and passenger. To minimise access times and maximise the potential catchment area, a bus stop should therefore be closely related to the footpath network and pedestrian crossings and sited at natural focal points of pedestrian movement such as in the vicinity of road junctions. All bus stops should also be wheelchair accessible wherever possible.
- 2.4.1.2 The ideal walking distance to a bus stop should not exceed 400 metres in urban areas. In rural areas it will often be necessary to accept longer distances. Where there are gradients in the urban footpath system, the walking distance should be reduced by 10 metres for every 1 metre rise or fall. The effect of pedestrian subways or bridges on walking distance must also be taken into account, as they will tend to reduce accessibility.
- 2.4.1.3 Whereas the primary consideration is to site bus stops conveniently for passenger usage, they should not be placed in positions where they may unreasonably interfere with the flow of vehicular traffic, restrict visibility on bends or at junctions, or where the footpath width is insufficient to provide waiting space for passengers. If unobserved, these points will lead to interference with both general traffic and with the movement of the bus itself, and can pose a hazard to passengers boarding and alighting from the bus. However, if a given site is thought to be the most attractive from a passenger point of view, arrangements should be considered to improve its conditions before putting forward alternative locations.
- 2.4.1.4 Bus stops generally serve passengers from both sides of the road used by the bus route, and use of the route will entail crossing the road in one direction. Whilst traffic and safety criteria must be observed, the relationship of stops to suitable crossing points is equally important to safeguard the passenger enroute to/from the bus stop. Where controlled pedestrian crossings or central refuges exist, bus stops should be sited on the exit side, with a minimum spacing of 20 metres from the termination of the zig-zag line to the bus stop boundary marking, in order to maintain adequate sightlines for general traffic, see Diagram 2.4.1.4.
- 2.4.1.5 Parking places should not be provided within 20 m of the bus stop area to safeguard bus approach and departure paths and to ensure a bus can stop close and parallel to the kerbside for the wheelchair users. This measure also allows buses to pull in close to the kerb so that passengers could avoid stepping onto the carriageway. This is relatively easy to ensure as on-street parking is only permitted in designated parking places under the Road Traffic (Parking) Regulations and the Fixed Penalty (Traffic Contravention) Regulations.
- 2.4.1.6 Picking up and setting down by vehicles other than buses should also be discouraged within 20 m of a bus stop, and where problems are anticipated, consideration should be given to the imposition of stopping restrictions having regard to the servicing of frontage properties.
- 2.4.1.7 The location of bus stops at junctions has to consider both traffic and safety criteria, together with the minimisation of interchange walking distances for the majority of passengers where two or more bus routes converge at the junction or intersect at crossroads.

2.4.1.8 In general it is preferable that bus stops should be located on the exit side of junctions even though the operator will prefer the approach side as alighting may occur during the stop phase of the traffic lights, and the option to make a turn at the junction will be retained (Location "X" in Diagram 2.4.1.4). In those cases where it is necessary to locate them on the approach side, they should be far enough away to ensure that:

- (i) A waiting bus does not obstruct the visibility of motorists on the side road or pedestrians crossing the main road at the junction.
- (ii) Other vehicles wishing to turn left are not obstructed by the buses.
- (iii) A bus requiring to turn right after leaving the stop has sufficient room to cross safely to the lane for right turning traffic.

Recommended spacings are shown in Diagram 2.4.1.8 for both types of siting.

2.4.1.9 For bus stops located on the far side of the junction, siting should conform to paragraph 2.4.1.8 (i) and Diagram 2.4.1.4 with regard to pedestrian crossing facilities. Further, the location of the stop should be such that vehicles turning left from the side road are not obstructed by waiting buses, particularly if there are no pedestrian crossing facilities.

2.4.1.10 Recommended standards have been devised incorporating the above principles and are shown in Diagram 2.4.1.8.

2.4.1.11 Generally speaking, bus stops should not be provided on trunk roads or on elevated sections of primary distributor roads. However, there may be exceptional circumstances where a bus stop is essential and in such cases, special arrangements will have to be considered in order to segregate the stopping bus from other traffic. These include:

- (i) Deceleration lane for buses upon entry into bus stop area.
- (ii) Physical separation between bus stop and through lanes (raised islands, profile barriers, etc.).
- (iii) Acceleration lane for buses upon entry into through lanes.

DIAGRAM 2.4.1.4: LOCATION OF BUS STOPS AT JUNCTIONS

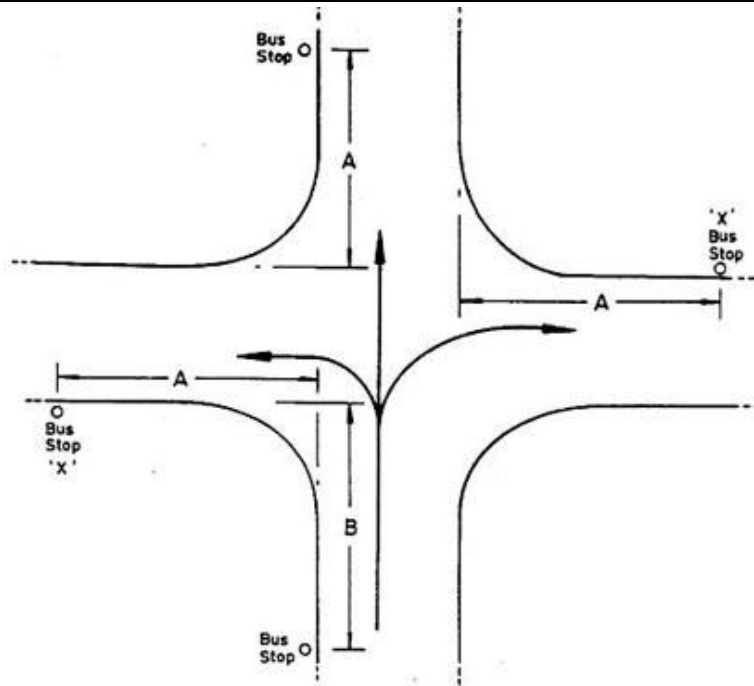

		A	B		
			BUSES STRAIGHT ON OR LEFT TURN	BUSES TURNING RIGHT	
				ONE OR TWO LANES AT INTERSECTION	THREE OR MORE LANES AT INTERSECTION
MAJOR JUNCTION	DESIRABLE	60 m	90 m	150 m	210 m
	MINIMUM	50 m	60 m	120 m	150 m
MINOR JUNCTION	DESIRABLE	50 m	60 m	100 m	NOT APPLICABLE
	MINIMUM	30 m	50 m	80 m	

DIAGRAM 2.4.1.8: LOCATION OF STOPS AT PEDESTRIAN CROSSINGS

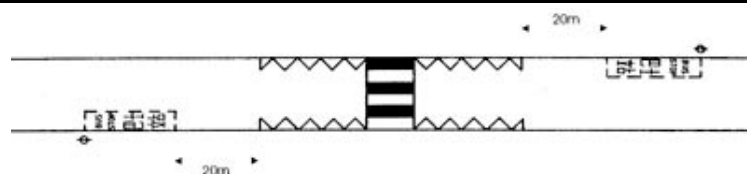

2.4.2 Spacing

2.4.2.1

The optimum spacing of bus stops will be dependent on the density and type of development, the average length of passengers' journeys, and the type of bus service. In many cases, it will represent a compromise between obtaining as high an operating speed as possible, and placing as many as possible stops within the acceptable walking distances of traffic generation and attraction zones.

2.4.2.2 Normally, the bus stop spacing should be around 400 metres in urban areas, although in rural areas longer spacing may be more acceptable where locations tend to be specifically related to traffic generators. Given the traffic congestion in urban area, the bus stop spacing may need to be longer say 600 metres. This will keep the maximum walking distance in-between the two stops to 300 metres, which is still within the ideal walking distance of 400 metres in para 2.4.1.2. The stop spacing could be shorter should traffic condition permits and demand justifies.

2.4.2.3 If more than one route operates along a road which may facilitate bus-bus interchange, the en-route bus stops of the concerned services should be located close to each other or use one common stop. Similarly, services travelling to similar destinations should use the same stop. If the overall level of service is such that the separation of stops is warranted, a 26 m space between bus stop poles should be provided to enable buses to pull in front of one another at the kerbside. The locations of stops to enhance passengers to interchange different bus routes are shown in Drawing 2.4.2.3.

2.4.2.4 Reductions in the above standard will pose difficulties for other traffic as buses unable to access stops properly will tend to reduce the effective road width, holding up other traffic, and making it impossible for the following waiting bus to pull away from its stop.

DIAGRAM 2.4.2.3: LOCATION OF STOPS FOR INTERCHANGE

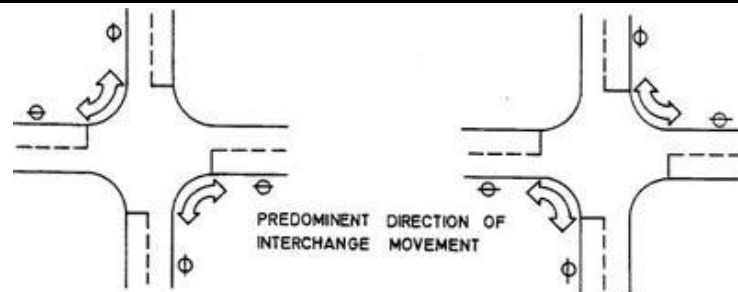

2.4.3 Stagger

2.4.3.1 Bus stops on opposite sides of a single two-way carriageway road should be staggered on safety grounds so that buses stop tail to tail and move off away from each other. The stagger distance should be a minimum of 40 metres. This is less important where lay-bys are provided, or on roads having a total of four or more lanes.

2.4.4 Bus Stop Road Markings

2.4.4.1 The bus stop location is a place designated under the Public Bus Services Ordinance where franchised buses may stop to pick up or set down passengers. The bus stop location will be indicated by road marking on the carriageway as illustrated in Diagram 2.4.4.1.

2.4.4.2 The overall minimum length of the marking is recommended to be 13 metres or its multiple, which should be repeated the requisite number of times where multiple bus stops are in force.

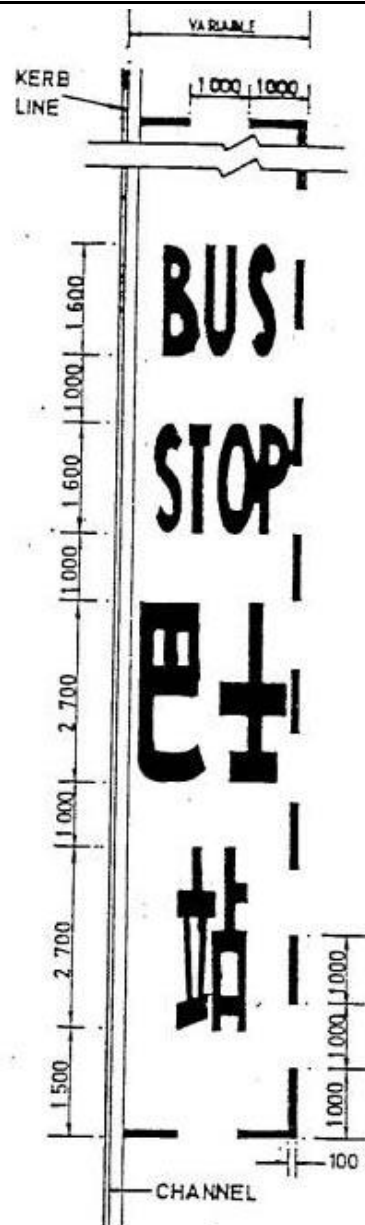
DIAGRAM 2.4.4.1: BUS STOP ROAD MARKINGS

TO INDICATE TO VEHICULAR TRAFFIC THE LIMITS OF A BUS STOP. "BUS STOP" AND "巴士站" MAY BE REPEATED ACCORDING TO THE LENGTH OF A BUS STOP.

STANDARD OVERALL MINIMUM LENGTH = 13 METRES OR ITS MULTIPLE

2.4.5 Bus Stops in Bus Lanes

- 2.4.5.1 The provision of bus lanes, as a traffic management measure, is designed to speed up the operation of buses in relation to other vehicles at congested parts of the highway network.
- 2.4.5.2 It is not intended to provide detailed advice on bus priority measures in this Chapter. Hence, only limited advice on the location of bus stops in bus priority schemes is given.
- 2.4.5.3 As bus lanes are intended to speed up the operation of buses, the provision of bus stops within the lane should be kept to a minimum in order to reduce potential delays.
- 2.4.5.4 Where bus stops are required, the following general advice is applicable, depending upon the type of bus lane in operation:

- (i) With flow - lay-bys may be required at difficult locations
- (ii) Contra flow - lay-bys required in most locations
- (iii) Bus Only Street - no lay-bys required

2.4.5.5 Normal standards relating to stop spacing and distance of stops from junctions may be relaxed, but this will depend on whether the exclusive bus lane continues to the stopline or not.

2.5 Bus Laybys

2.5.1 General

- 2.5.1.1 Bus laybys are provided to enable buses to stop for boarding/alighting passenger without obstructing other traffic. It is important to note that although bus laybys benefit non-bus traffic, they can often introduce significant delays for buses on departure with no benefits to the passenger or operator.
- 2.5.1.2 The provision of laybys should therefore be carefully considered, and not automatically proposed for every new bus stop location. However, there are circumstances where they should be actively encouraged for traffic management or safety reasons, particularly on single carriageway roads.
- 2.5.1.3 Within the hierarchy of roads, laybys should be considered for rural roads A and B, feeder roads, primary distributor roads and 2-lane 2-way single carriageway district and local distributor roads. On district and local distributor roads with two or more lanes, bus laybys may be omitted.
- 2.5.1.4 There are other factors which should be taken into account when deciding on the appropriateness of a bus bay, amongst which is the fact that once a layby is constructed the bus stop position becomes fixed, whereas a normal on-street stop can be relocated relatively easily if required. Secondly, if a layby is provided in a location where severe delays are experienced by buses on departure, bus drivers will tend to stop outside the layby on the carriageway, causing passengers to walk across the bus bay to board the bus.

2.5.2 Location

- 2.5.2.1 As bus bays are located at bus stops, the locational criteria set out in paragraph 2.4.1.1 to 2.4.1.11 are also relevant. Their locations are dictated by bus passenger demands and a need to minimise access times and maximise potential catchment area. They are normally located between 400m to 600m apart in urban areas. In rural areas a longer spacing may be acceptable.
- 2.5.2.2 However, where they are provided in the vicinity of a junction, this should be on the exit side to avoid conflict with left-turning traffic, and potential difficulties for the bus driver in rejoining the traffic stream, particularly where there are queues or the bus has to make a right turn. In these vicinities, laybys should conform to a similar siting pattern as that adopted adjacent to pedestrian crossings and described in paragraphs 2.4.1.4.

2.5.3 Layout

- 2.5.3.1 There are a number of possible configurations for laybys, all of which are outlined in section 2.5.4.
- 2.5.3.2 In general, the crossfall of the bus bay should fall from the kerb to the carriageway to reduce the risk of splashing whilst keeping the gradient of the crossfall to a minimum to avoid exaggerating the step height into the bus.
- 2.5.3.3 The bus layby construction should be reinforced concrete to avoid carriageway deterioration caused by fully laden buses braking at speed and the effects of diesel spillage. The surface should have sufficient texture depth to provide good adhesion under braking.

2.5.4 Types of Layby

- 2.5.4.1 The standard layby is designed to accommodate 12 metre vehicles with adequate run-in and run-out to allow buses to pull in close to the kerb and parallel to it. Diagram 2.5.4.1 illustrates a standard layby for one bus together with tabulated details for minimum design criteria.
- 2.5.4.2 Diagram 2.5.4.2 gives dimensions for a standard multi-bus layby, whilst Diagram 2.5.4.3 illustrates the layout for standard single bus multiple stops, where each bus is required to enter and leave independently of the other.
- 2.5.4.3 The open-ended layby as shown in Diagram 2.5.4.4 is a variation on the standard arrangement, and has two main advantages in that the stop may be closer to the junction, and the overall length of the layby may be reduced. This is advantageous to bus passengers, whose walking distances are reduced. However, the layout also has a number of disadvantages such as :
- (i) more expensive than a standard layby by virtue of the greater area of carriageway required to be constructed, plus the potential problems with underground services which tend to be more prevalent at road junctions;
 - (ii) reduces the footway width at junction where pedestrian needs are greatest; and
 - (iii) likely to encourage drivers to enter into the bus layby area than with most other configurations.
- 2.5.4.4 Diagram 2.5.4.5 illustrates a combined layby, which is an extended layby, provided to accommodate parking spaces for other vehicles in addition to buses at the bus stop. For this type of layby it is desirable to incorporate physical segregation between the bus stop and the remainder of the layby to protect the bus run-in and run-out from parked vehicles. If this is not done, buses will be unable to pull into the layby and passengers will be forced to enter the carriageway. Where physical segregation is not possible due to site constraints, the use of appropriate traffic signs and road markings should be considered.
- 2.5.4.5 The foregoing standards may be modified where the circumstances at the proposed location dictate from a cost, space or operational point of view. In such circumstances, the dimensions shown in Diagram 2.5.4.1 need only be provided for example where the bus must be drawn clear of the nearside lane. On single lane carriageways where the lane widths exceed the required minimum a reduction in depth as shown in Diagram 2.5.4.6 is acceptable. Similarly where the footway width is insufficient and cannot be increased a narrower layby may be preferable to not providing one at all.
- 2.5.4.6 The unit length of 13 metres used in determining the capacity of a layby is based on Transport Department's maximum permitted length for a rigid public service vehicle. Under certain circumstances, the bus bay length may be reduced to suit specific situations. For example, some roads may only permit the operation of small buses. In addition, the distance between buses at stops in a multi-stop layby may also be modified accordingly, provided that the nearside traffic lane is of sufficient width to prevent existing buses from sweeping into adjacent traffic lanes.

DIAGRAM 2.5.4.1: STANDARD BUS BAY SETTING OUT DETAILS

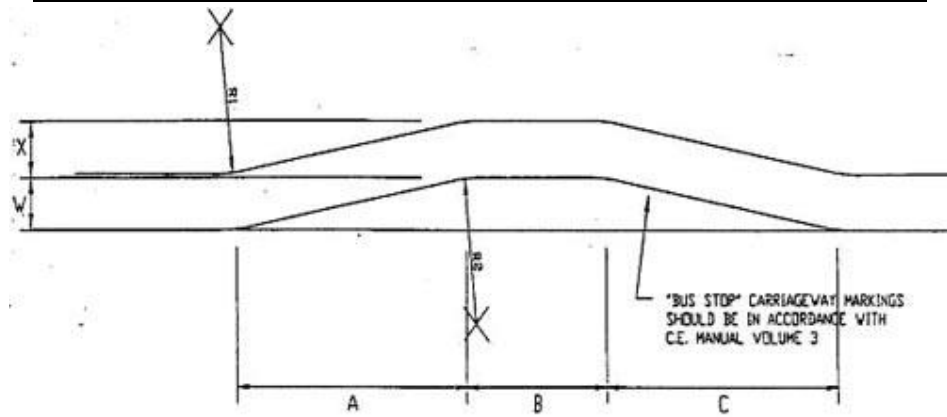

	R1 (m)	R2 (m)	A (m)	B (m)	C (m)	W (m)	X (m)***
STANDARD SETING OUT DETAILS	18	12	20	13	20	3.25	3.50
MINIMUM SETING OUT DETAILS	15	12	15	13	15	2.75	2.75
SUB-STANDARD ABSOLUTE MINIMUM	10	10	10*	13	10	1.50**	2.00

- * This dimension may be reduced to 7.00 metres providing W is at least 3.00 metres in width
- **This dimension may only be used where insufficient width is available, and the carriageway is at least 6.75 metres wide.
- ***The influence of bus shelters on footpath capacities is important, see paragraphs 2.6.3.1 TO 2.6.3.5

DIAGRAM 2.5.4.2: STANDARD MULTI-BUS LAY-BY

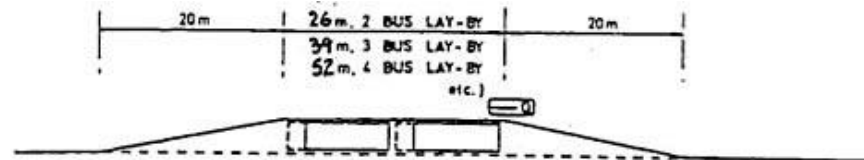

DIAGRAM 2.5.4.3: STANDARD SINGLE-BUS/MULTI-STOP LAY -BY

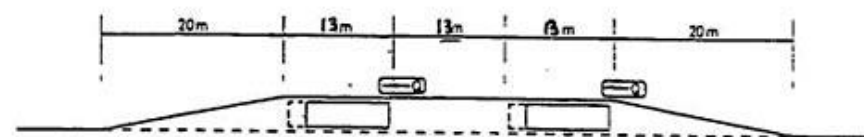

DIAGRAM 2.5.4.4: OPEN-ENDED LAY-BY

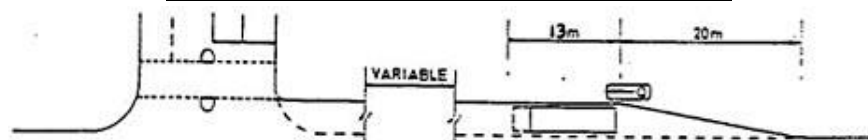

DIAGRAM 2.5.4.5: STANDARD COMBINED LAY-BY

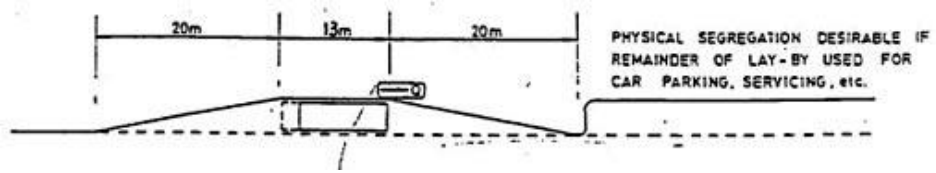
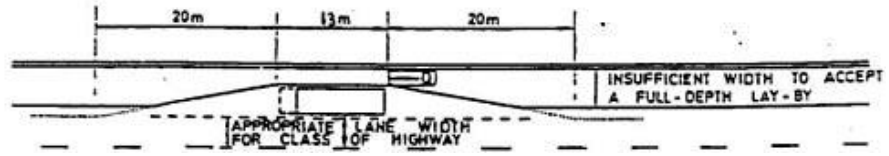

DIAGRAM 2.5.4.6: LAY-BY WITH SUB-STANDARD DEPTH



2.6 Bus Shelters

2.6.1 General

2.6.1.1 For the travelling public, it is widely accepted that waiting time is the most important deterrent to travel by public transport. It is therefore of paramount importance to minimise any discomfort involved whilst waiting by providing passenger shelter wherever possible.

2.6.1.2 The provision of bus shelters also assists in regulating passengers waiting for buses such that at least the majority do not wait on the carriageway or bus bay area where they are at risk from buses or other passing traffic.

2.6.1.3 The Public Bus Services Ordinance stipulated that the provision and maintenance of bus shelters is the responsibility of the franchised bus companies. To better service the passengers, they will draw up an annual shelter construction programme after taking into account the views from District Councils and the public. The priority of bus stops for erection of shelters can be determined by the following quantitative method :

(i) For Potential Usage of Bus Stop by Boarding Passengers

(a) Calculate the total boarding passenger waiting time in peak hours for each route/stop.

$$W_{pijb} = B_{pij} \times H_{pj} \times E_{sr} \times \sum_{t=1}^M P_t (t-1/2)/60 \text{ passenger hour}$$

where W_{pijb} = total boarding passenger waiting time in peak hour period for route j at stop i

B_{pij} = total number of peak hour boarding passengers of route at stop i

H_{pj} = average peak hour bus headway (Min.) of route j

E_{sr} = 0.54629
= probability of exposure to sunshine ($E_s = 0.45634$) + probability of exposure to rain ($E_r = 0.08995$)

$\sum_{t=1}^4 P_t (t-*)$ = weighted average number of headways waited during peak hour period.

P_t = assigned probability of waiting for t^{th} bus headway before boarding

$P_1 = 0.7856$	$P_2 = 0.1684$
$P_3 = 0.0361$	$P_4 = 0.0099$

(b) Calculate the total boarding passenger waiting time in off-peak hours for each route/stop.

$$W_{oijb} = (B_{oij} \times H_{oj})/2 \times E_{sr}/60 \text{ (passenger hours)}$$

where W_{oijb} = total boarding passenger waiting time in off-peak hour period of route j at stop i

B_{oij} = total number of off peak hour boarding passengers of route j at stop i

H_{oj} = average off peak hour bus headway (Min.) of route j

E_{sr} = 0.54629

(ii) For Potential Usage of Bus Stop by Alighting Passengers

- (a) Calculate the total alighting passenger hour usage at each route/stop
- $$W_{aij} = A_{ij} \times E_r \times * \text{ (passenger hours)}$$
- where W_{aij} = total alighting passenger hours of exposure to rain of route j at stop i
- A_{ij} = total number of alighting passengers at each route/stop in all hours of route j at stop i
- E_r = 0.08995
= probability of exposure to rain
- * hour = average duration of taking cover for rain

- (iii) Calculate the Total Passenger Waiting Times WT

$$WT = W_{pijb} + W_{oijb} + W_{aij}$$

Since the boarding and alighting volumes are obtained from historical studies, updating of WT for each route/stop by the passenger volume ratio is required.

$$WF = \frac{WT \times \text{Route Volume in September 1999}}{\text{Route Volume at Survey Time}}$$

- (iv) The adjacent WF is then weighted by the environmental index, EI of the route/stop:

$$WFEI = WF \times EI$$

- 2.6.1.4 This fairly exhaustive procedure has enabled a complete hierarchical breakdown of the bus stops under consideration and their ranking into an order of priority. Under normal circumstance and due to tight working schedule, the franchised bus companies will give priority to erect shelters at bus stops with heavy boarding activities and high public requests. The detailed computation to rank the stops will seldom be carried out.
- 2.6.1.5 When designing bus shelter, due consideration should be made to no impediment to the normal operation of existing and future facilities nearby. These include land status, road projects, water pipes, underground drains, geotechnical risks, police security implications, and shop owners' views. Consideration should also be given to reserve sufficient underground space for building the footings of shelters when laying cables and pipes near bus layby or stop. More specific requirements are given in the following paragraphs.
- 2.6.1.6 As a general guideline, a 1.5m all-round clearance should be maintained at fire hydrant's outlets and its ground valve. On the other, the bus shelter should cause no obstruction to the ingress/egress of any designated EVA.
- 2.6.1.7 The shelter should be at least 2 metres away from the tree trunk. No excavation or building materials stockpile against the tree trunk. No tree felling or pruning is permitted. Proper drain should be provided on the roof of the bus shelters to prevent accumulation of water thereon. Regular cleansing service should be provided to prevent accumulation of refuse on the roof of the shelters.
- 2.6.1.8 Isolated footings should be constructed for installation of bus shelter when there is existing/proposed water main in the vicinity. No footing of bus shelter should be constructed above any existing water main without the prior approval of WSD. All footings of bus shelter should be constructed to have a minimum clearance of 300mm from any existing water main in the vicinity. For drainage, no foundation of the bus shelters shall sit over or across any public drains, manholes, desilting openings and the like.

- 2.6.1.9 From landscape and visual point of view, the location should not adversely affect existing trees, pedestrian movement, cyclist at adjacent cycle track, traffic signs, access points and shop front. For narrow pavement adjacent to grassed area, possibility of placing the footings of bus shelter in the grassed area should be explored in order to maximise the effective width of pavement and shelter. Should the concerned section of pavement is already protected by existing canopy, no bus shelter should be erected.
- 2.6.1.10 In terms of the design, only shelter design accepted by the Advisory Committee on Appearance of Bridges and Associated Structures of Highways Department should be adopted. In order to maintain the character of the street, bus shelters in vicinity should be compatible in appearance. New bus shelter should either adopt a similar design of the existing one or otherwise, all existing shelter(s) should be replaced together with the new one as far as possible.
- 2.6.1.11 Basically, bus shelters should be forward facing. The reserve type should only be adopted when other possible options are found not feasible. T-shape shelter with its narrow section facing the carriageway should be considered as reserve type as people tend to stand on the other side of the shelter to keep distance from carriageway. Narrow type shelters provide little protection from sunshine and inclement weather. Its use should be restricted to narrow footpath where other wider shelter is found not feasible.
- 2.6.1.12 Clearance requirements as required by TD, Buildings Department and maintenance authority of adjacent structure are provided in Table 2.6.1.1. For situation that there is insufficient space to separate the bus shelter from pedestrian circulation, the bus shelter should be set back as much as possible to maximise the effective width of the footpath.

Table 2.6.1.1 Proposed Minimum Clearance for Erection of Bus Shelters under the most Common Scenarios

Minimum Clearance (metres)		Shop	Building without Shop Frontage		Wall/ Slope	Bus Terminus
			With Entrance/Exit	Without Entrance/Exit		
(a)	Horizontal clearance from roof of shelter to kerb for safety reason	0.5	0.5	0.5	0.5	0.5
(b)	Horizontal clearance from roof of shelter to frontage of adjacent structure for passage of pedestrians	1.8	1.1	0.35*	0.75*	---
(c)	Radial clearance # from roof of shelter to nearby wall/balcony/ floor for security reason	2.5	2.5	2.5	---	---

Notes:

* Shelters will be erected close to wall/slope or housing developments, wall/planters so that more spaces will be available on the pavement for pedestrian movements.

Radial clearance means the radius of the nearest point of the shelter roof to the nearby wall/balcony/first floor.

2.6.1.13 The main function of panels is to protect bus shelter users from sunshine and inclement weather. It is also important to maintain access to/from and view of adjacent areas, in particular of coming buses and adjacent pedestrian or cycling movement. For back panels, as a rule of thumb, an opening with a meter wide should be allowed for every 3 meters of advertisement panels. However, should there be a number of bus shelter placed in line, cumulative effect of advertisement panels as screen wall should be avoided by increasing the number of opening. For side panels, no side advertisement panel should be erected in the direction of coming buses.

2.6.2 Shelter Design

2.6.2.1 In the past, bus shelters were provided by franchised bus operators in accordance with Highways Department's design standards as shown in Diagram 2.6.2.1. In recent years, some franchised bus companies have provided new shelter designs at respective bus stops. The details are illustrated in Diagrams 2.6.2.2 to 2.6.2.4.

2.6.2.2 In designing bus shelters, a number of standards should be taken into account, namely:

- (i) Support pillars to be RSC box sections or tubular steel of 90 - 100mm in diameter.
- (ii) Structure to be capable of withstanding wind speeds between 80 - 133 knots. The design pressure range should be between 2.7 - 3.0 kN/m.
- (iii) Where kick panels and glazing are to be installed, these should be fixed in beading no less than 25 mm in width. Where steel rivets are used, cadmium plating is preferred.
- (iv) All structural members and fasteners, other than aluminium and stainless steel, to be hot-dip galvanised to BSEN ISO 1461:1999 or equivalent.
- (v) Glass shall be safety glass or Plexiglas.
- (vi) Rainwater from shelter roof should be drained to underground drainage system via down pipes.
- (vii) Provision for wheelchair access to the front of the queue.
- (viii) When transparent roof and panels have to be used, consideration in design should be taken in respect of their degree of transparency, and the proportion and distribution of the transparent parts so that passengers' comfort will not be adversely affected. Sunlight/heat reduction materials should be used for transparent roof and panels. Other installations that would improve passengers' comfort, such as ventilation fans (subject to availability of electricity supply) should also be considered.
- (ix) Installation of wind panels might be required for bus shelter where the bus stop is prone to strong wind.

2.6.2.3 The resultant design, being mainly of steel and glass, would give the impression of a lightweight airy structure, the large areas of glazing both reducing the impact of the shelter on the immediate surroundings and improving bus driver/passenger visibility and traffic sightlines.

2.6.2.4 The basic shelter unit could be further enhanced by the addition of various ancillary components which embrace advertising, publicity, and information panels, internal illumination, rainwater disposal, seating, public address systems, queue rails and litter bins.

2.6.2.5 A shelter module of this nature is usually constructed in two basic formats, known as the cantilever or enclosed type. For reasons of passenger safety, bus service identification, and accommodating front

entrance, centre-exit buses, all shelters should be located such that the queue faces approaching traffic, the bus stopping at the shelter exit point, the head of the bus queue. This positioning allows passengers to alight from the bus with a clear footpath free of queue railings or waiting passengers. It should be noted that when used at laybys, this arrangement has the inherent disadvantages of creating an area of potentially unusable space between the shelter and the carriageway. Consideration should be given in such instances as to how the area may be treated - e.g. landscaping or hard surface.

2.6.2.6 Of the two types of shelter format described, it is considered that the cantilever type is the most appropriate arrangement for Hong Kong – as it absorbs less pavement space and can be provided at lower cost. Its main disadvantages is the requirement to have a substantial foundation to counteract the effect of wind pressures on the cantilever roof, which could lead to problem of installation (conflict with services) in urban areas.

2.6.2.7 A potentially typical arrangement for a cantilever shelter is shown in Diagram 2.6.2.5, indicating basic dimensions, and structural details in accordance with design standard suggested in paragraphs 2.6.2.3 (i) to (vii).

DIAGRAM 2.6.2.1: BUS SHELTER-GENERAL LAYOUT
SCALE 1:50 OR AS SHOWN

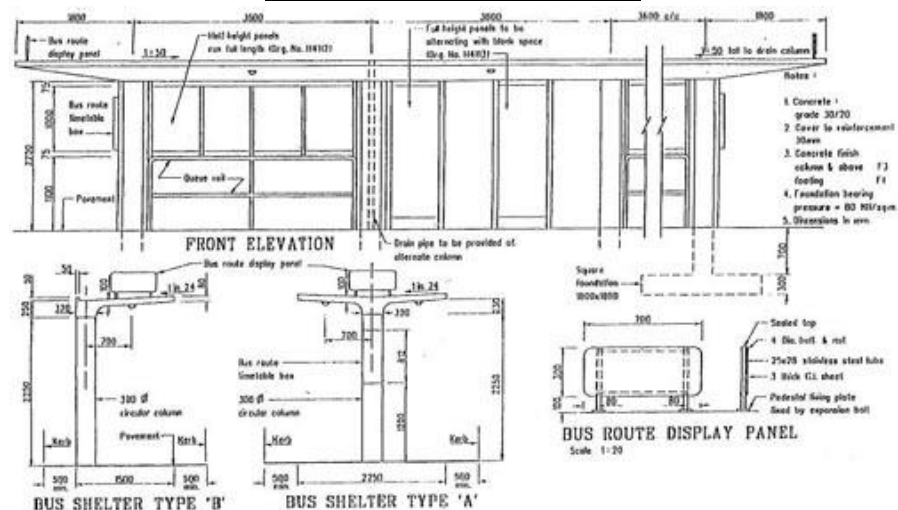

DIAGRAM 2.6.2.2: KMB BUS SHELTER (NOT TO SCALE)
ALL DIMENSIONS IN MILLIMETRES

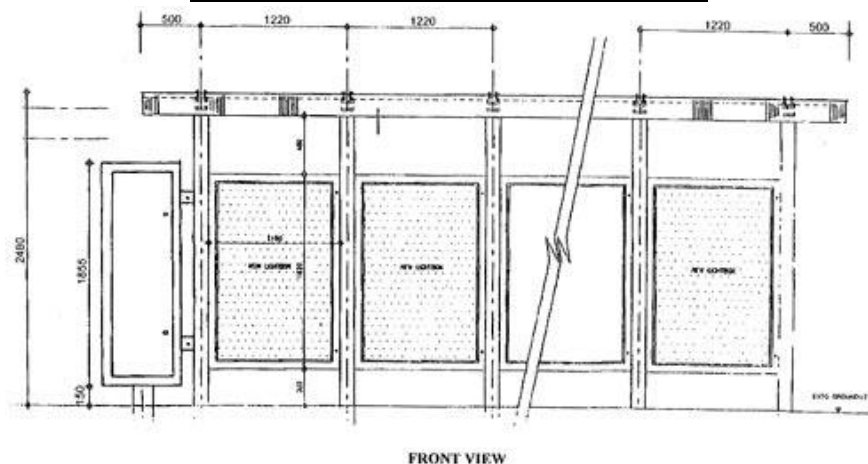

DIAGRAM 2.6.2.3: KMB BUS SHELTER (NOT TO SCALE)
ALL DIMENSIONS IN MILLIMETRES

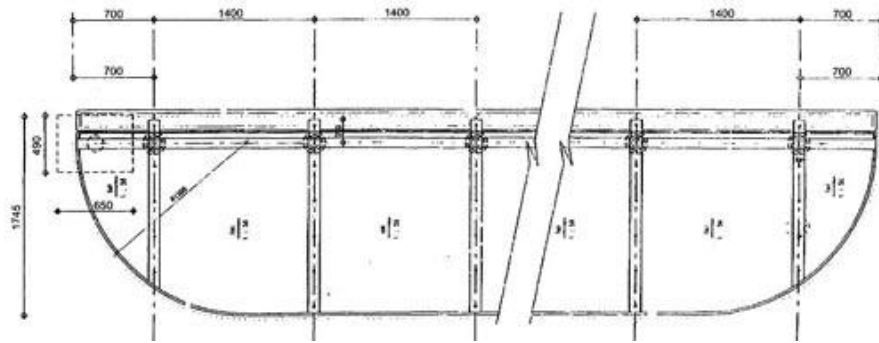

DIAGRAM 2.6.2.4: CITYBUS BUS SHELTERS (BY TEXON)

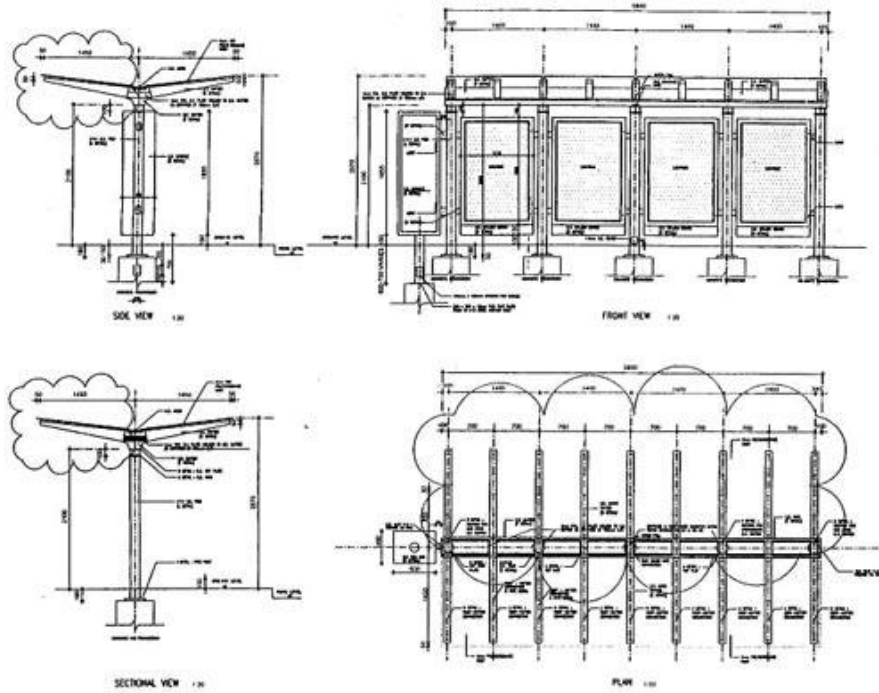
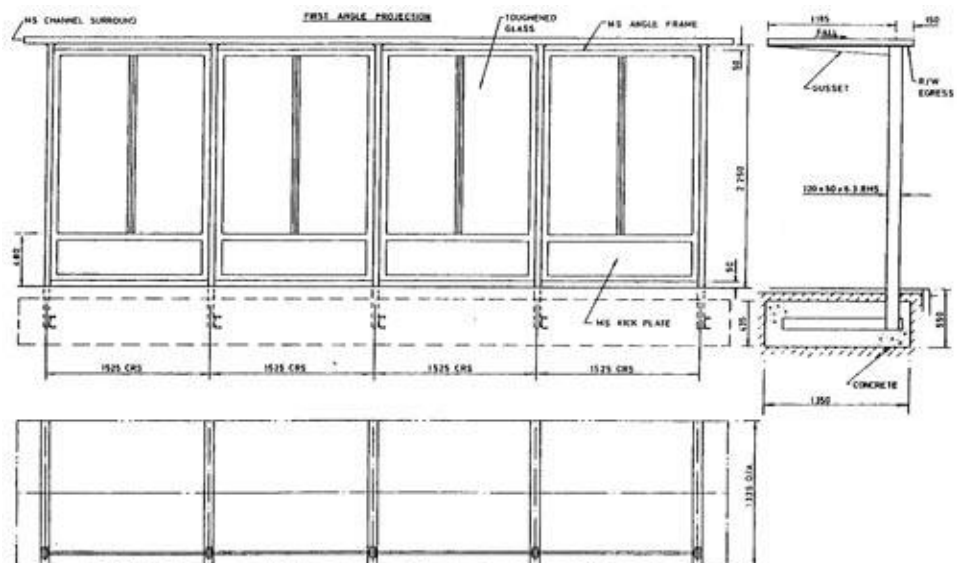

DIAGRAM 2.6.2.5: NEW MODULAR DESIGN FOR CANTILEVER SHELTER



2.6.3 Shelter Layout and Queuing Arrangements

- 2.6.3.1 Where bus shelters are provided, appropriate clearances must be maintained for general pedestrian traffic on footways. The Street Furniture and Greening Zone width should be increased for installation of bus shelters. If bus shelter exceeding 1m width is provided along the footway corridor, additional width up to 2m should be suitably allowed in the Zone. Volume 6 Chapter 10 Section 10.5 and Table 10.5.5.1 give some basic guidance. Flexibility could be allowed with justifications to cater for specific site and planning context and site circumstances.
- 2.6.3.2 Data on pedestrian flows in Hong Kong is fairly limited, but it would appear from transport related surveys that peak flows tend to occur at lunchtime where shopping crowds reach the highest levels.
- 2.6.3.3 From paragraph 2.6.3.1 and 2.6.3.2 it would seem reasonable to plan for a standard minimum pavement clearance of 3m where space permits.
- 2.6.3.4 Diagrams 2.6.3.1 (a) to (e) show some potential layouts for cantilever shelters without queue railing. These layouts can provide passengers with special needs to access easily to the front of the queue and board buses using the wheelchair ramp.
- (i) Layout (a) - Generally speaking, this layout is preferred as it affords maximum protection for intending passengers, encourages more orderly queuing and minimises any conflict with general pedestrian traffic.
 - (ii) Layout (b) - This layout is almost identical with (a), except for the addition of one end panel, which affords greater protection for passengers and allows the option of putting in an extra advertising panel in a prominent position.
 - (iii) Layouts (c) and (d) - These two layouts place the shelter at the back of the footway where sightline constraints render the establishment of shelter at the kerb edge unsafe from a road safety viewpoint. This has the disadvantages of mixing intending passengers with general pedestrian traffic, affords minimal protection on boarding/alighting from buses in the wet, and is limited in application due to the requirement to have a blank wall or absence of development behind the screen.
 - (iv) Layout (e) - This layout has the disadvantages referred to in paragraph 2.6.2.6.
- 2.6.3.5 Each layout is shown without the provision of queue railings which has the advantage that pedestrians can utilise part of the pavement space under the shelter roof, thereby reducing the overall pavement width requirement. Conversely, it has the disadvantage of having potentially less orderly queuing, and is therefore more suitably applied in those locations where pavement widths are restricted, or where pedestrian pavement flows and/or the usage of the bus stop is low.
- 2.6.3.6 Queue railings should be provided at most bus stops where boarding volumes are sufficiently high to generate regular queuing. At stops which are lightly used, or where they are located close to terminal points on the outward routing and are used mainly for alighting, no queue railing need be provided. Further, at locations where the available pavement width is severely limited and where the provision of a shelter is justified, queue railing may again be omitted.
- 2.6.3.7 Queue railing should be laid out in such a manner that passengers boarding the bus are able to step directly into the entrance of the bus and passengers alighting may do so without conflicting with queuing passengers or railings. Most existing queue railing layouts have been effectively designed for rear platform buses, and with the largely front entrance/centre exit arrangement now predominating alighting passengers are let down onto the small area between the queue rail and the nearside of the bus. With the large rear overhang of most modern double deckers, buses moving away from the kerb that subsequently apply some of the steering lock generate a potentially dangerous hazard to any

remaining passengers. This is particularly acute with buses having rear overhangs in excess of 3 metres, see Table 2.3.3.3.

- 2.6.3.8 Revised standards for queue railings are therefore recommended as shown in Diagram 2.6.3.2 (A) and (B). The standards shown relate to the recommended modular shelter design discussed in paragraphs 2.6.2.3 to 2.6.2.8. However, most configurations are suitable for the Highways Office Type "A" and "B" shelter, and are very similar to the dimensions applied in the layout of queue railing that is incorporated into the KMB shelter.
- 2.6.3.9 Queue railings may of course be provided at locations where there are no bus shelters, particularly in the urban areas where the presence of overhead canopies may render the provision of shelters unnecessary. Modifications to the traditional layout may also be considered at certain locations, if site conditions are particularly restrictive.
- 2.6.3.10 The configuration shown in Diagram 2.6.3.2 (A) is suitable where there are relatively narrow footways and the number of queuing passengers is low. Where there is greater demand, additional queuing space may be created by doubling up the rail as shown in Diagram 2.6.3.2 (B).
- 2.6.3.11 The width of the queuing aisle in both these examples is shown as 600 mm. This represents the absolute minimum, and is only recommended where the bus stop is used by one route. For stops observed by more than one route, the queuing aisle is recommended to be increased to a minimum of 900 mm in order to allow queuing passengers to pass one another.
- 2.6.3.12 En-route bus stops away from termini can usually accommodate several services that are operating to similar destinations. An existing example is shown in Diagram 2.6.3.3, reference to which indicates that little distinction has been made between the number of routes using each stop and the length of the queue railing. As such this type of layout is not recommended, and an arrangement based on Diagram 2.6.3.2 (B) with 900 mm aisle widths should be adopted.
- 2.6.3.13 There will be instances where queuing volumes en-route are sufficiently high to justify segregation of routes amongst adjacent bus stops. The existing standards for queue railings to cater for this situation where adjacent bus stops use the same shelters is shown in Diagram 2.6.3.4. It will be noted that this arrangement is contrary to the general layout proposed in Diagram 2.6.3.2 (A) and (B) and is therefore not recommended.

2.6.3.14

Diagram 2.6.3.5 shows the preferred setting out details for queue railing at adjacent stops, which incorporates the ideal spacing between stops described in paragraph 2.4.2.3, derived from tests conducted for linear bus stands which is shown in Diagram 2.9.5.1. The recommended stop spacing assumes that the driver pulls the bus up with the front entrance aligned at 90 degrees to the head of the shelter queue. This produces an effective stop spacing of 24 metres with a 17 metre spacing between queue railings. This spacing produces good results with regard to dimensions B and C (Diagram 2.6.3.5), which allows the bus to pull up virtually parallel to and adjacent to the kerb line, and to depart behind a stationary bus. Reductions in spacing A to say 12.7 metres will result in a value of 2.06 metres for spacing B and 0.23 metres for spacing C. This will cause the rear end of the bus to encroach across the centreline by 1.2 metres on a 6.75 metre carriageway, and such reductions in spacing are therefore not recommended.

DIAGRAM 2.6.3.1: SITING ARRANGEMENTS FOR CANTILEVER SHELTERS WITHOUT QUEUE RAILINGS

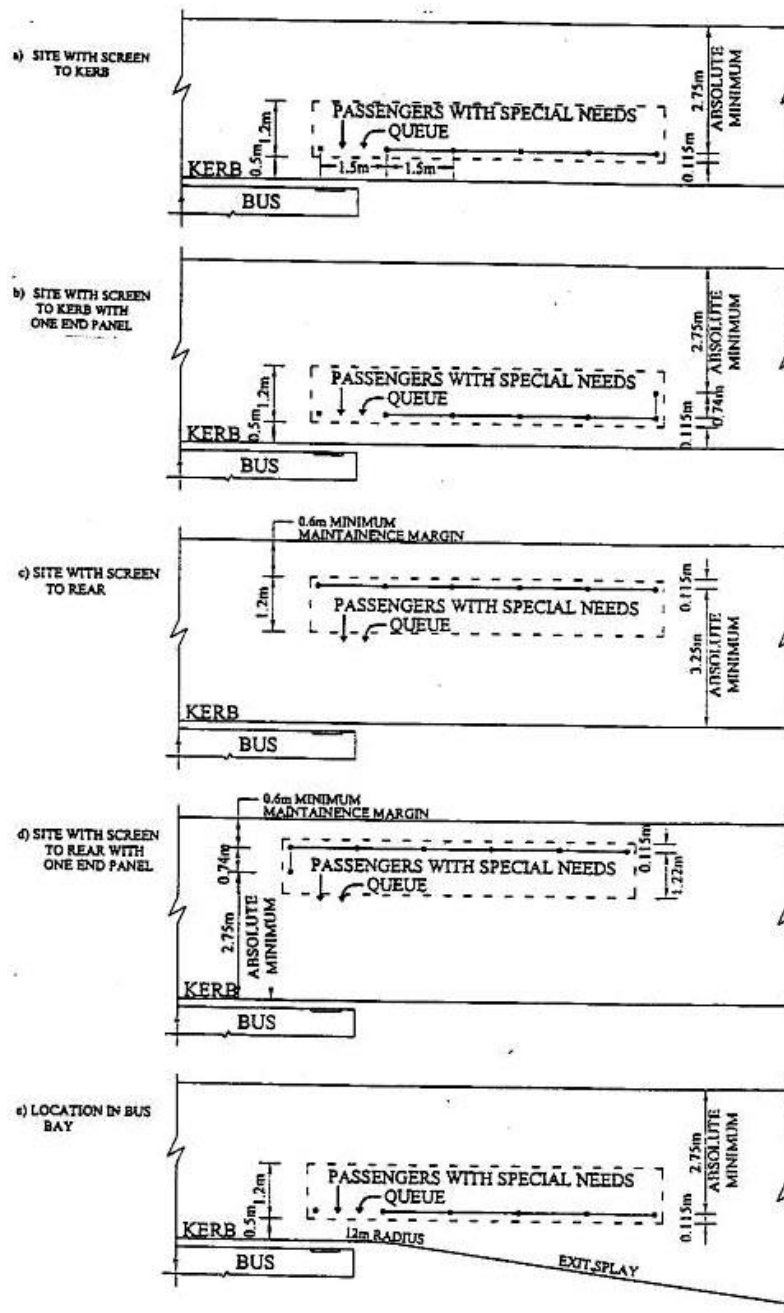

DIAGRAM 2.6.3.2: SETTING OUT DETAILS FOR STANDARD QUEUE RAILING WITHIN MODULAR SHETLER

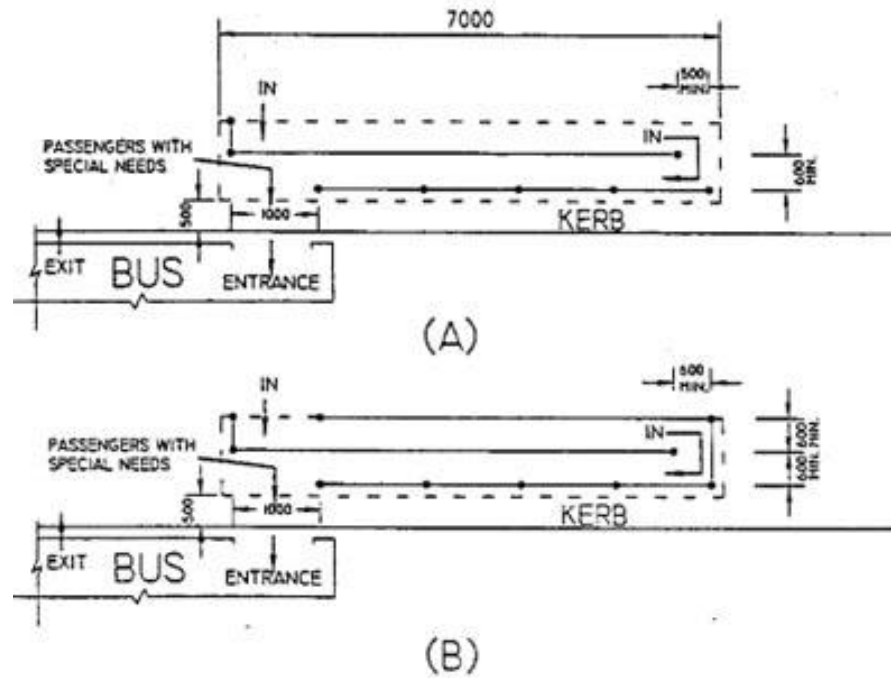
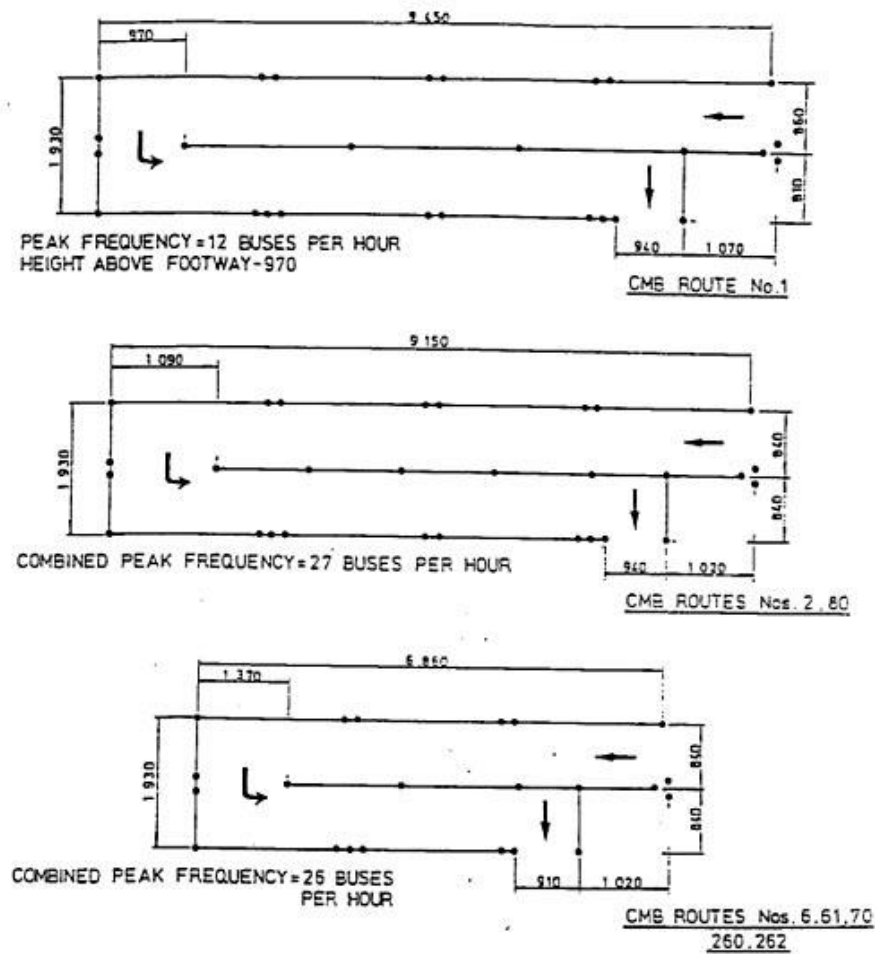

DIAGRAM 2.6.3.3: PREVIOUS BUS QUEUE RAILING ARRANGEMENTS ALL DIMENSIONS IN MILLIMETRES

CONNAUGHT RD.C. CITY HALL-HONG KONG



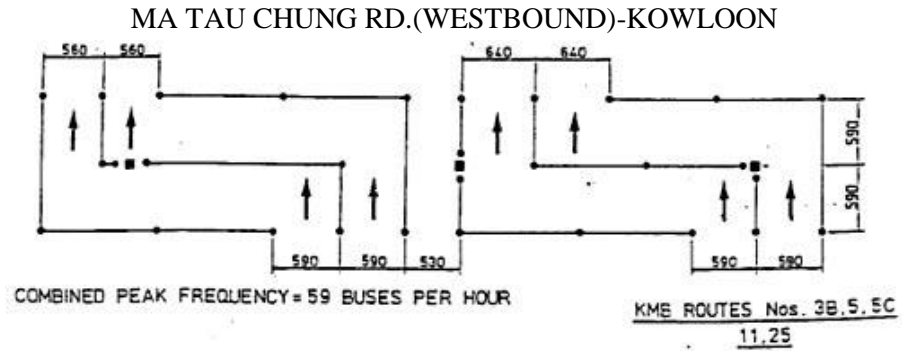

DIAGRAM 2.6.3.4: PREVIOUS BUS QUEUE RAILING ARRANGEMENTS FOR TYPE 'A' BUS SHELTERS FOR ADJACENT STOPS (NOT RECOMMENDED)
SCALE 1:100
ALL DIMENSIONS IN MILLIMETERS

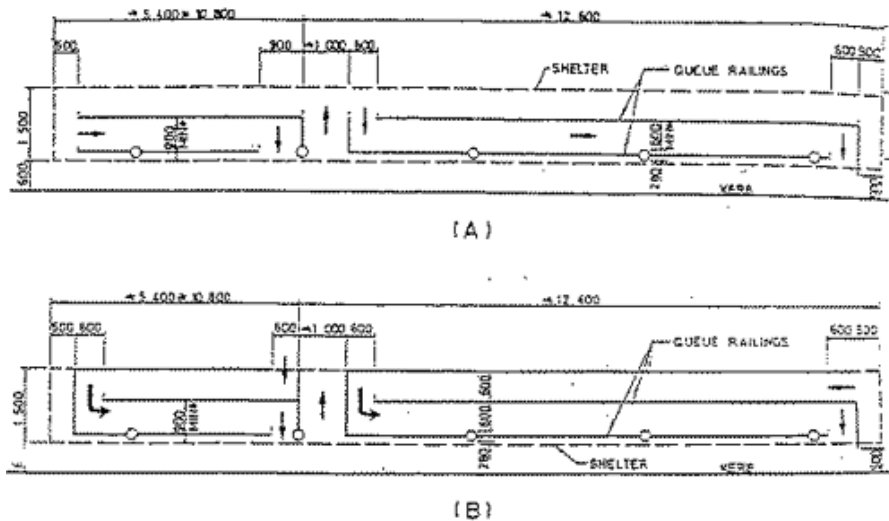
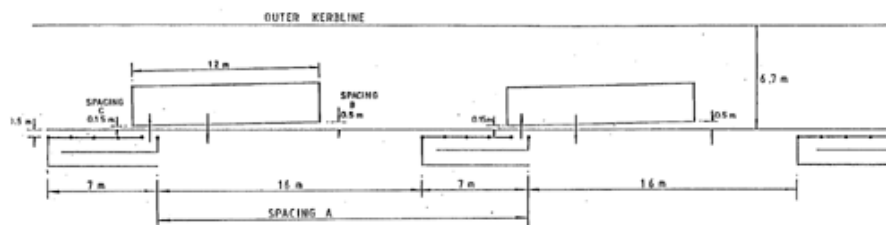

DIAGRAM 2.6.3.5: SETTING OUT DETAILS FOR STANDARD QUEUE RAILING AT ADJACENT STOPS
SCALE 1:200



2.7 Design Standards for Bus Terminal Facilities

2.7.1 Introduction

2.7.1.1 The purpose of this section is to introduce the latest standards set by TD and the Hong Kong Planning Standards and Guidelines (HKPSG) for the design of bus terminal facilities.

2.7.1.2 Most of the existing termini provide the basic passenger waiting facilities and they are not very effective in encouraging passengers to use public transport in terms of safety, comfort and convenience. Hence, the current designs have limited manoeuvrability for bus operators.

2.7.1.3 If the existing standard of the bus termini is to be upgraded by the bus operators, they have to bear all the cost incurred.

2.7.2 Categories of Terminal Points

2.7.2.1 In general, every bus route requires two terminal points which fall into three basic categories, namely:

- (i) a service terminal point which is a simple turning facility that gives access to a stacking area that may be in the form of an off-street lay-by;
- (ii) a bus terminus which includes bus turning, stacking and passenger waiting facilities and accommodates a number of routes; and
- (iii) a public transport interchange which includes provision for buses, minibuses, taxis and possibly park and ride facilities.

2.7.2.2 In general, the number of departure bays in the first type of facility is unlikely to exceed four. It accommodates one or two terminating routes with a maximum of 5 vehicles.

2.7.2.3 The last two types of facility are similar in concept, although different in terms of size and resultant layout. A minimum of 4 departure bays should be provided at the bus terminus. If bus-bus interchange is to be pursued at the bus termini, additional bays would be required. All facilities providing a greater number of bays for different modes will be termed as a public transport interchange. These are dealt with in Section 2.7.5.

2.7.3 Service Terminal Points (STPs)

Location

2.7.3.1 A service terminal point will usually comprise a simple local facility that enables buses to turn around. It will therefore take up little space and involve a simple geometric design with fairly low construction costs. In many cases, this can be achieved on the highway using a roundabout, gyratory, or 'round the block' route, or off the highway in a purpose-built bus terminus. A regulator's kiosk, a staff rest room and toilet facilities will be required at the service terminal point.

2.7.3.2 At some terminal points, particularly in the outer areas where no suitable facility may exist, a bus turn-round must be provided in order to eliminate the need for buses to reverse. The need to eliminate reversing is essential with the widespread introduction of one man operation using rear engined buses which are particularly difficult for vehicles to reverse.

2.7.3.3 If possible, STPs should be provided off-street, with access and egress points not in conflict with traffic circulation. In general, STPs should be located as close as possible to the main centre of demand. In order to enhance the attractiveness of public transport, the facility should be related to connecting pedestrian routes from adjacent housing estates, with a minimum of conflict with vehicular traffic.

2.7.3.4 Where STPs are provided in new housing estates, these should be located at the furthest side of the estate. The bus will then be routed through the estate picking passengers up en-route, thereby minimising their walking distances.

Layout

2.7.3.5 This manual mainly concentrates on the two dimensional aspects of design, with the exception of gradients and crossfall. Level sites are always preferable, but where this is not possible gradients should not exceed 7% on circulation roads or approach ramps, and along departure bays should not exceed 4%. Gradients across passenger platforms should not exceed 3.3% and longitudinally should not exceed 4%.

2.7.3.6 Dependent on the direction of circulation and side of carriageway, whether approach side or departure side, there is a wide range of layout designs for STPs. These are illustrated schematically in Diagram 2.7.3.6. From these layouts nos. A1 and A8 may be used for comparative purposes of sites adjacent to the Approach Side and similarly D1 and D8 for the Departure Side, as intermediate layouts merely relate to the direction of circulation, shape of available site and individual or combined entrance and exit.

2.7.3.7 Comparing layouts A1 and A8, it will be seen that both sites have the disadvantage that being immediately adjacent to the approaching bus the left hand entry turn will produce a very wide opening with all excessive pedestrian crossing length. However layout A1 does have the advantage that the exiting bus will be virtually square to the highway and have the best possible sightlines where the opposite is true of layout A8.

2.7.3.8 Comparing layouts D1 and D8 it will be seen that both will have acceptably narrow entrances as more of the space required for the swept path will be absorbed within the width of the highway; additionally D2 has the advantage of good exit vehicle positioning, and sightlines.

2.7.3.9 These foregoing examples relate to instances where the adjacent highway is straight. If the adjacent highway is curved, any site located on the outside of the curve will have much better sightlines than on the inner side, and again the site on the Departure Side of the outside curve has the advantage of turning movements over those where the outside curve is on the Approach Side. However, it should be noted that STPs should only be located on curves in exceptional cases when special facilities such as separate turning lanes can be provided.

2.7.3.10 In summary, sites located on the Departure Side of the bus route are to be preferred as:

- (i) the entrances (and hence pedestrian crossing facility) will be narrower.
- (ii) the right-hand entry turn off the highway and the left hand exit turn are easier to execute than that obtaining for Approach Side sites.

2.7.3.11 Of all the Departure Side layouts D8 is preferable on safety and general traffic circulation grounds, and it has the advantage of utilising the inside of the terminal as a passenger queuing and waiting area for both the terminating and passing services. Although pedestrians will have to walk across the carriageway, this can be safely provided as presented in Diagram 2.7.3.11.

- 2.7.3.12 Various alternative layouts for the service terminal point based on type "D1" are shown in Diagram 2.7.3.11. The basic layout shown in Diagram 2.7.3.11 (A) provides space for one terminating bus and allows the exit manoeuvre to be made without crossing the carriageway centreline. Diagram 2.7.3.11 (B) shows a modification incorporating a standard one-bus layby for a possible passing service. This layby can be used for a second terminating bus - Diagram 2.7.3.11 (C) - in which case the second bus has the facility to depart before the first bus. This overall layout as shown in Diagram 2.7.3.11 (D) has an operational capacity of five buses, all contained off the highway.
- 2.7.3.13 In Diagram 2.7.3.13, the typical layout dimensions are given for this design for 12 m vehicles on full lock. There will be many locations where the site characteristics or operational requirements do not permit the use of this standard layout and a specific design to meet the site constraints will have to be developed.
- 2.7.3.14 It should be noted that these designs are primarily for one route and there is no passing facility within the service terminal point. However, there are many examples in the Territory where service terminal points are used by one route only and where very rudimentary facilities currently exist for turning buses round, and where there is considerable potential for improvement, given available space. Where there is a requirement to accommodate more than one route, the lane width on the straight of the service terminal point can be increased to a minimum of 6.7m, with a preferred design width of 7.3m.
- 2.7.3.15 It is not considered economical to provide more than two stands at a service terminal point, and for termini catering for more than five buses, linear stands should be considered. Diagram 2.7.3.11 (D) illustrates the ideal maximum capacity of a service terminal point, and where larger facilities are required, the linear stand bus terminus should be considered.
- 2.7.3.16 All STPs should be constructed with concrete carriageways to minimise maintenance costs and disruption, and to avoid carriageway deterioration from diesel and oil spillage. In any design, provision should be made for bus stops, passenger shelters, queue railings, footpaths and lighting and where necessary, landscaping and barrier rails.

DIAGRAM 2.7.3.6: ALTERNATIVE CONFIGURATIONS FOR SERVICE TERMINAL POINTS

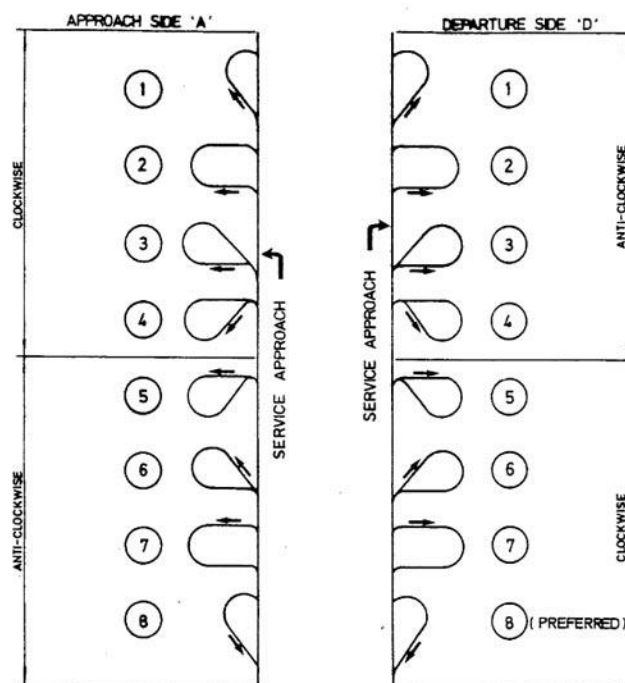

**DIAGRAM 2.7.3.11: STANDARD LAYOUT DESIGNS FOR SERVICE TERMINAL POINT
TYPE 'D1'**

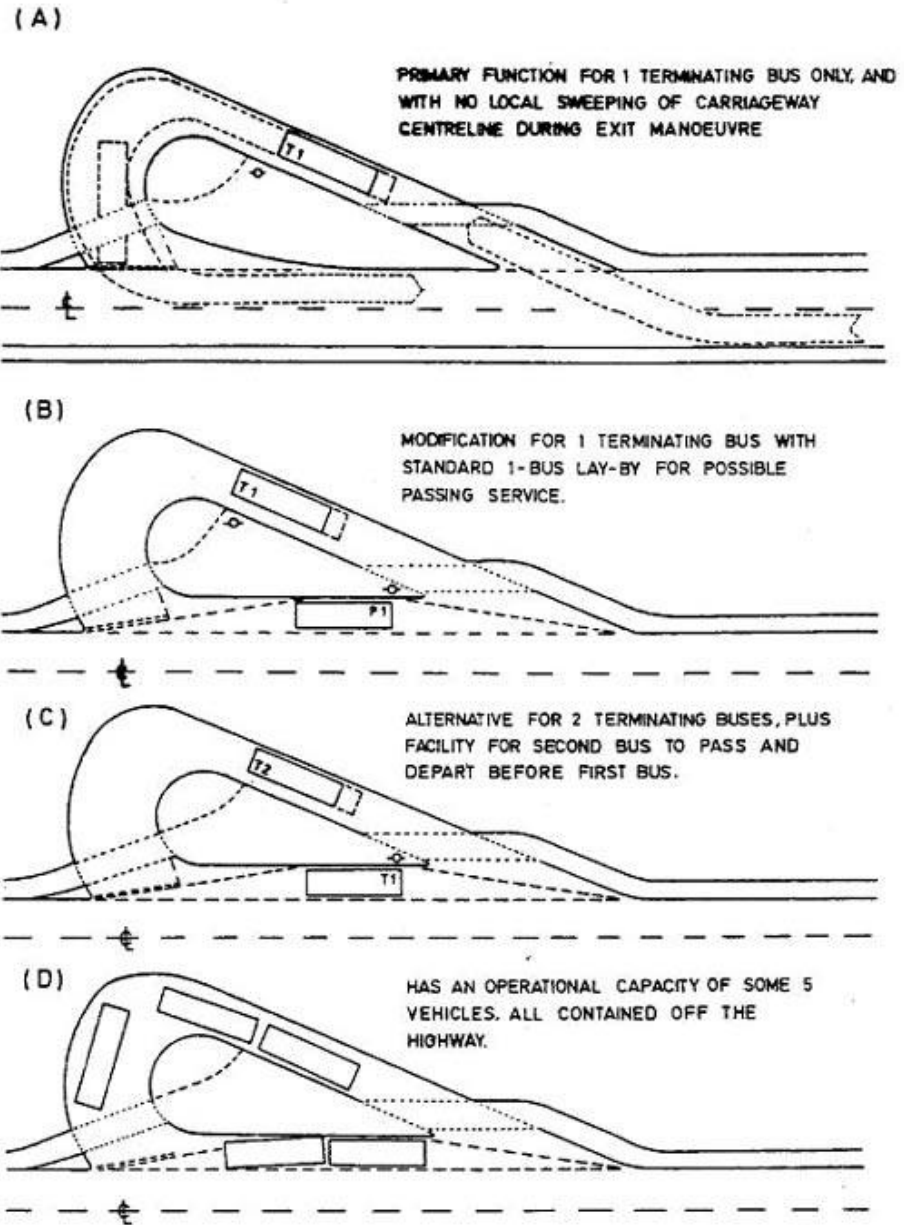
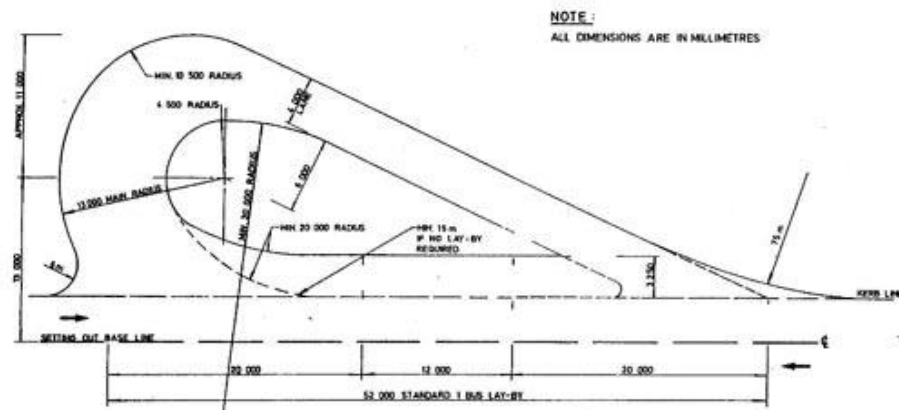

DIAGRAM 2.7.3.13 TYPICAL SETTING OUT DETAILS FOR STANDARD SERVICE

TERMINAL POINT

SCALE 1:250



2.7.4 Bus Termini

Location

2.7.4.1 Bus termini are usually provided in large residential developments, particularly public housing estates, and in localised commercial or industrial areas. For operational efficiency and passenger convenience and safety, all bus termini should be located off-street. A regulator's kiosk and the other ancillary provisions would be required.

Layout

2.7.4.2 The land requirement for a bus terminus is determined by several factors which include the number of routes served and their peak frequency, passengers waiting and pre-departure stacking, the mix of terminating and through service, overtaking and internal vehicle and passenger circulation. Normally, a linear bus terminus will have one double-width bay of 7.3m in width to permit overtaking of stationary vehicle for every 5 single-width bays. For single-width bays which do not allow for any overtaking, the desirable width between stands should be 3.5m. The nose of stand islands should be a bull nose, with a preceding taper not exceeding 2m provided by road markings not kerbs.

2.7.4.3 To enhance the accessibility of bus termini, all platforms should be wheelchair accessible, with passenger islands ranging in unobstructed clear width from 1.8m to 2.7m. The lower standard will be adopted if the peak hour carrying capacity of the bus route is less than 1,500 passengers. The width of the island refers to the unobstructed clear width, i.e. dimension excludes the presence of queue railing, shelter, or the width of supporting columns for termini with developments above.

2.7.4.4 Desirable length of the bays for bus termini is set at 40 metres. In terms of bus stacking and operation, a linear bay layout provides 1 boarding/alighting space and 2 spaces for stacking for each bay. If only one route is assigned to one bay, there will be 2 stacking spaces for each bus route. At both ends of the islands, entry and exit splays with 11.6 metre and 15.2 metre curve radii for inside and outside bends are to be provided, with allowance for reverse routing.

2.7.4.5 Within the circulatory arrangement of the bus termini, the layout must allow for a 12m bus to turn on an outside wheel radius of not less than 15m at any point. External radii within termini of 15m with an additional 3m being added to the circulation aisle is suggested.

2.7.4.6 Circulation aisle widths, assuming that the parking of buses along aisles will not occur, are:

- (i) 17m for 90 degree turn
- (ii) 14m for 60 degree turn
- (iii) 12m for 50 degree turn
- (iv) 8m for 30 degree turn

2.7.4.7 Internal radii at entrances and exits should not be less than 11m but larger radii may be necessary for some situations. Elaborate entry and exit lanes are to be avoided, whereas the straight-through entry and exit layout is advised with some guidance given on swept turning circles, these being 23.7 metres in diameter in most cases, whereas 22.5 metres is stated to be acceptable in certain cases.

2.7.4.8 It is recognized that the layout of bus terminus in the Territory is very much determined by site limitations. The rigid application of the existing standard will produce some very substandard facilities. It is highly desirable that the proposed detailed design of the terminus, including the layout, is circulated to the operator for comment before it is firmed up for construction. Road tests are required upon completion of the bus terminus to identify the necessary modifications. Considerations should also be given to the maximum dimensions of buses that will operate in the terminus.

2.7.4.9 Painting of alternate black and white striped marking at kerbs and alternate black and yellow striped marking at barriers could be considered at appropriate locations such as entrances, exits, bus bays, critical bends, etc. as necessary to improve the visibility and contrast of kerbs and barriers inside the bus termini. The striped markings should be uniform. Except the two ends of boarding platforms where striped marking at a pattern as shown in Diagram 8.9.1.1 of Volume 6 Chapter 8.9 should be applied, the striped markings at kerbs should be elongated at 1m interval in the direction of traffic because of the low angle at which the markings are viewed by the drivers. In addition, the striped markings at barriers should slope forward at an angle of 45° with respect to the direction of traffic. Typical details of striped markings at kerbs and at barriers are shown in Diagrams 2.7.4.1 and 2.7.4.2 respectively.

DIAGRAM 2.7.4.1: TYPICAL DETAILS OF ALTERNATE BLACK AND WHITE STRIPED MARKING AT KERBS

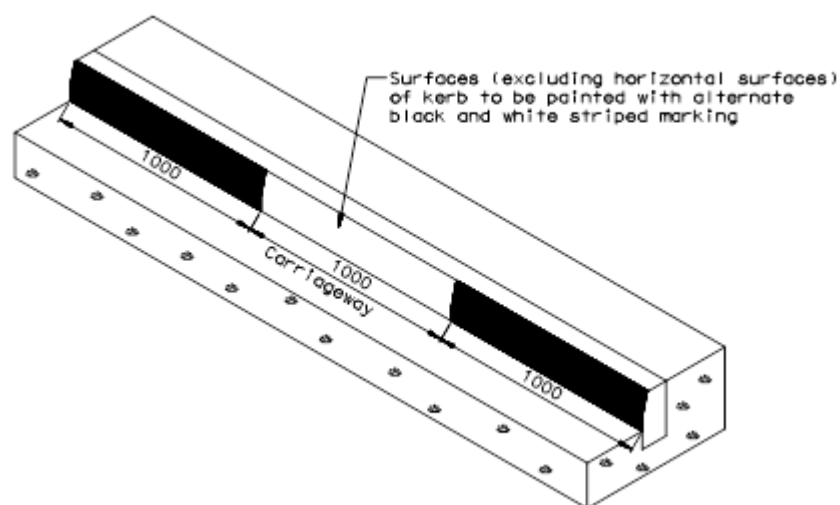
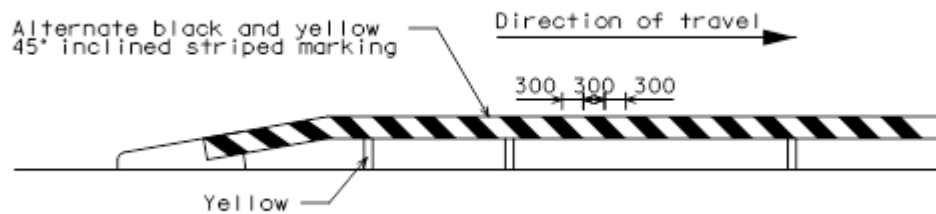

DIAGRAM 2.7.4.2: TYPICAL DETAILS OF ALTERNATE BLACK AND YELLOW STRIPED MARKING AT BARRIERS



2.7.5 Public Transport Interchanges (PTIs)

Location

2.7.5.1 PTIs are usually provided in town centres, or other regional focal points where passengers interchange between services and modes. In general, a public transport interchange should be centrally located so as to be conveniently accessible on foot to residential, commercial and industrial activities. Access to the existing and proposed road system should be convenient and the ingress and egress points so located as not to cause conflict with traffic circulation on the adjacent road system and to facilitate satisfactory internal circulation.

2.7.5.2 Theoretically, PTIs should be provided off-street as far as possible for the following reasons:

- (i) to avoid disruption to traffic
- (ii) to provide proper queuing areas for passengers
- (iii) to provide proper terminal space for operators
- (iv) to provide a turn round facility

2.7.5.3 The advantages of a PTI over a scattering of on-street stands can be summarised as follows:

- (i) Provides the opportunity to centralise control and staff facilities
- (ii) Provides an improved passenger environment and facilities; e.g. passenger information
- (iii) Provides for easy interchange between services
- (iv) Provides an easily-identifiable focal point for passengers
- (v) Removes stationary buses from the highway.

2.7.5.4 The main disadvantage lies in cost, both capital and bus operating, which will usually be substantial compared to on-street.

2.7.5.5 For bus terminus which forms part of a PTI, its access should be physically separated but walking distances between modes should be minimal. As bus termini have potential to cause air pollution and noise impacts on nearby sensitive uses, they should be so sited or designed in the PTIs as to minimise such impacts.

2.7.5.6 Bus-bus interchange schemes may be introduced at strategic or major PTI to reduce the number of buses accessing the urban area. Hence, additional bays should be included at bus termini of the PTI at the planning stage if the schemes will be pursued thereat.

2.7.5.7 Theoretically, there should be a PTI next to each railway/MTR station (excluding Light Rail Stations) so that the catchment for the railway station can be increased by feeder services. However, for MTR stations in Hong Kong SAR, especially those in business districts, such as Wan Chai, most passengers walk in/out. Rail passengers can also be fed to such stations through passing services.

Layout

2.7.5.8 Detailed design standards for PTI are given in Volume 9, Chapter 8 of the Transport Planning and Design Manual.

2.7.6 Determination of quantities, capacities and design concepts of bus stands

2.7.6.1 The capacity of a bus stand is determined by the number of buses per hour, layover time, passenger boarding flows and rates, and level of reliability. To determine the number of stands required, it is necessary to examine the service patterns to be operated. Diagram 2.9.4.1 illustrates the effect of reliability on capacity for a single bus stand. It can be seen that as reliability improves, stand capacity increases rapidly; conversely as layover and boarding times increase, stand capacity reduces. Table 2.7.6.1 indicates the capacities currently obtained from a sample of bus termini in the Manchester area of U.K. which illustrates the effect of layover/reliability on stand capacity.

Table 2.7.6.1 Examples of Stand Capacities in Manchester, U.K.

Type of service	No. of peak hour departures on arrival		
	Stand size	Mean	Maximum
Terminating	single	5	12
Terminating	double	9	16
Through	single	10	16
Through	double	14	35*

* on-street stand

2.7.6.2 It is important to consider other operational factors such as the need to accommodate inter-timed services, or routes serving common destinations, on the same or adjacent stands. It is also important to incorporate sufficient flexibility to take into account future changes in service patterns. There are three basic variations in design concept which are illustrated schematically in Diagram 2.7.6.2.

- (i) Buses arriving draw onto their appropriate stand for passengers to alight, to stand time (layover) and to allow passengers to board. This is one of the most common concepts in operation in the Territory.
- (ii) Buses arriving draw onto a common alighting stand and then pull onto the appropriate stand for layover and departure. This is a common arrangement at ferry piers e.g. Star Ferry at Tsim Sha Tsui. Pedestrian arrival and departure flows may be therefore segregated and walking distances reduced if passenger objectives are in the direction of incoming buses. The total number of stands will probably be little more than those required at (i).
- (iii) Buses arriving draw onto a common alighting stand and then pull into a ranking area to stand time, pulling onto a boarding stand about 2 minutes before departure time. A smaller number of departure stands will then be required, but a proportionately greater passenger queuing area

- 2.7.6.3 In both types (i) and (ii) in paragraph 2.7.6.2, a parking area for out-of-service buses will still be required to accommodate vehicles with long layover times, or on stand-by. The area required for ranking out-of-service buses is a significant problem in the Territory because of the following operational practices which are generally adopted by some franchised bus operators e.g. KMB:
- (i) Buses and drivers are allocated to the same routes for each working day.
 - (ii) There is very little interworking of services.
 - (iii) Mealbreaks are provided at termini (usually the town centre) by simply taking both the bus and driver out of service. This results, particularly when coupled with buses taking layover, in up to 75% of the buses allocated to a particular route being parked up at a terminus for limited periods.
- 2.7.6.4 Careful consideration must therefore be given to the requirements of the two types of out-of service parking, beginning with layover times.
- 2.7.6.5 Generally speaking, layover times are a function of the total round trip time on a service divided by its frequency. Layover can be calculated by multiplying the number of buses allocated to a route by the peak frequency, and then subtracting the total round trip time. An example is given below:
 Peak Bus Allocation = 20
 Peak Frequency = 5 mins
 Journey Time = 45 mins
 Peak Bus Allocation x peak frequency = 20 x 5 = 100
 Total round trip (journey time x 2) = 45 x 2 = 90 mins
 Total excess time (layover) = (100-90) mins = 10 mins
- 2.7.6.6 The above will result in a layover of 10 minutes, which will usually be divided equally at each end of the route. In this case, the layover time is equal to the frequency and this should mean that only one bus is on the stand at any one time. In reality however, once alighting and boarding time have been added onto the layover period, another bus will have arrived, and even in these instances high frequency services will require a double stand. Two layover spaces are recommended (excluding the space for active loading and unloading) for each terminating route. This is justified having regard to the above comments and the need to allow for bunching due to traffic congestion en-route and longer layover time during meal-break.
- 2.7.6.7 The off-peak situation is little different to the scheduled peak position. There is a problem of early arrival at termini during in the less congested parts of the territory. As the bus companies only schedule departure times from termini, this could generate excessive layover periods at termini with the resultant implications for overcrowding.
- 2.7.6.8 There are several ways that this problem can be minimised. Firstly, operators can adopt differential running times which reflect peak and off-peak journey times, thereby minimising late running in the peak and early running in the off-peak period. This can be added to by specifying scheduled arrival times at termini. The second method available to operators is to allocate the bulk of any layover within the working timetable to the outer termini, often patronised by one service. For example, KMB Route 89B (Pok Hong to Kwun Tong) has most of its layover allocated to the Sha Tin end of the route because of terminal problems in Kwun Tong. Conversely, NWFB Route 11 (Central Bus Terminal - Jardine's Lookout) is operated as a circular route with the bulk of its layover allocated to the Central end. In this case, reversing the position would provide more capacity in Central which is already grossly overcrowded.

2.7.6.9

Layover taken for mealbreaks is a different issue. Operators should be encouraged to spread the period over which meal-breaks are taken by developing mealbreak 'cycles' and minimising the number of buses that require to be parked up at the same time. Whereas this will entail drivers using more than their customary one bus per duty, and will increase the overall driver requirement, it will reduce the requirement for terminal space. As a matter of essential policy, this demand should be met by a separate area which should be set aside within the bus terminus for out-of-service parking, the only buses parking on departure stands being those operating the next departure on each service.

2.7.6.10

The requirement for mealbreak parking can also be reduced by encouraging operators to allocate the bulk of any mealbreaks within the bus working timetable to the outer termini, often patronised by the one service. Alternatively, buses can be relieved en-route at depots, and other strategic locations, drivers taking their mealbreaks at these points, whilst the bus continues in service with another driver. These are some of the many possible solutions to a complex problem that is becoming increasingly important to resolve if the pressure on central area termini is to be reduced and proper and safe facilities for passengers provided. The requirements regarding the lay-over of buses should be considered in the planning and design stage.

DIAGRAM 2.7.6.1: EFFECT OF RELIABILITY ON STAND CAPACITY

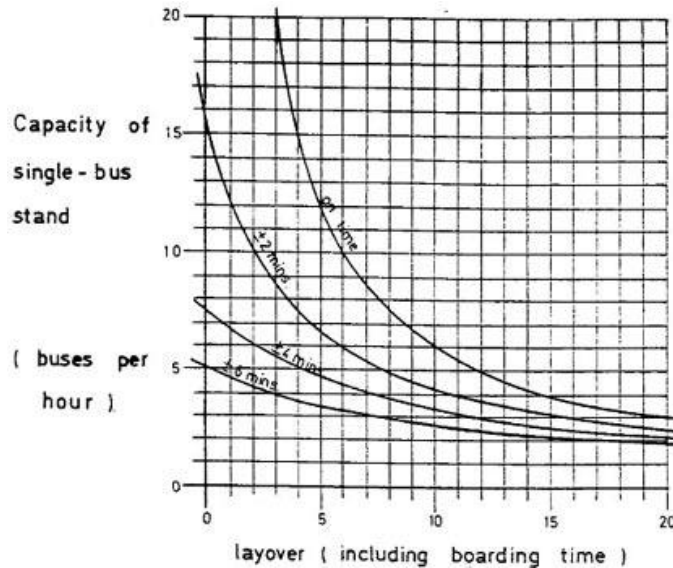
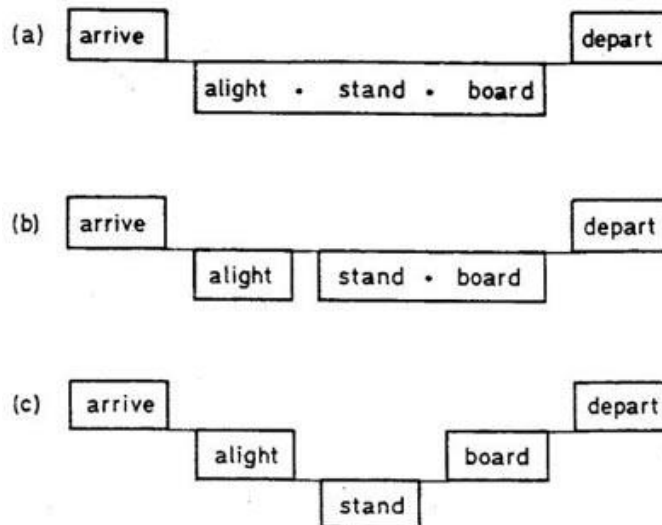

DIAGRAM 2.7.6.2: VARIATIONS IN DESIGN CONCEPT



2.7.7 Selection of Stand Type

- 2.7.7.1 There is an almost infinite range of stand types, depending on the position of a stationary bus to the kerbline. The critical angle of the bus to the kerbline is 15° , past which point buses have to reverse in order to depart. For this reason, only those stands which permit forward departure paths are considered in detail.
- 2.7.7.2 These stand types fall into two categories, namely linear and shallow sawtooth. Currently, most examples of stand exists in the Territory are of the linear type, where separate narrow passenger islands are provided for each service, and usually with no ability for buses to pass one another. However, the design of multiple pick-up/drop-off bays within the same platform has to be considered along with the overall layout of the bus terminus.
- 2.7.7.3 Linear bus stands are a straight forward arrangement whereby buses are positioned around one or more large passenger islands, the most important design element being the spacing between stands. Diagram 2.7.7.3 shows some typical results of several series of tests which have been carried out to determine the stop spacings required for a 12 metre bus, on a linear or straight kerbline, with a minimum-width carriageway of 7.3 metres, and without sweeping the footpath. As the suggested absolute lane width required for buses to pass on the straight is 3.5 metres, and as the width of the angled bus in the test is still 2.5 metres, the maximum kerb offset for parked buses on a 7.3 metre wide linear carriageway is 0.7 metres which virtually rules out the first two tests as being too close to practical limits.
- 2.7.7.4 The range of practical stop spacings for the 12 m bus falls between 13.7 m and 29 m depending on the standard of parking that is acceptable in relation to the door positions of the bus in question. The optimum spacing of 29 m does allow the bus to pull parallel to the kerbline, but may be considered over-generous in most situations. A stop spacing of 24 m should therefore be adopted as the standard as shown in Diagram 2.7.7.3, with a minimum carriageway width of 7.3 metres. The sketch in Diagram 2.7.7.4 shows the standard setting out details for linear bus stands for 12 m vehicles.
- 2.7.7.5 The shallow sawtooth stand is a variation on the linear bus stand, and is designed to accommodate more buses along a given kerbline than is possible with linear stands.
- 2.7.7.6 Diagram 2.7.7.5 illustrates the basic layout of the shallow sawtooth stand and demonstrates its three main variables, namely
- (i) Length of the loading kerbline (in this case 14 metres) which determines (ii) below
 - (ii) Depth of the shallow sawtooth zone in relation to the spins of the pedestrian island, being in this case about 2.5 m
 - (iii) Width of the bus bay, in this case 2.5 m.
- 2.7.7.7 The above example allows buses to approach the stand on a straight path adjacent and parallel to the preceding bus, thereby eliminating the reverse curve-approach manoeuvre and permitting buses to achieve the desired parking position close and parallel to the kerb. However, it also produces an excessive pulling in and pulling out distance.
- 2.7.7.8 This latter factor can be eliminated by increasing the angle of the sawtooth (at the same time reducing the stop spacing) to such a point that relates all three variable factors above in the most economical way before reaching a point where reversing is required.
- 2.7.7.9 Diagram 2.7.7.9 illustrates the derivation of the maximum angle of exit assuming a forward transition distance of 2.5 in along the vehicle centreline, this being twice that required if full lock is applied when stationary, and two thirds that required if full lock is applied when moving.

- 2.7.7.10 A further variable dimension, the width of the bus bay, has been identified by adopting a minimum of 2.8 m, and the bus has been positioned 1 m back from origin 0 to allow for the transition to the exit lock and a 3 m kerb radius between boarding and exit kerblines, which leaves 1 m between rear of a 12 m bus and the sawtooth peak, or 3.25 for a 9.75 long vehicle.
- 2.7.7.11 By construction, the derived maximum angle between loading kerblines and exit kerblines is 34° . By simple calculation, dimensions $AO = 5.01$ m and $AB = 18.40$ m (overall stand length at stop spacing) and $AOB = 146^\circ$, thus producing a fixed relationship. On a continuous platform 'AB' must be parallel to the platform spine, and the resulting dimensions are derived in Diagram 2.7.7.9 producing an 'optimum' layout. A series of field tests have been carried out independently to derive actual dimensions, and these are compared in Diagram 2.7.7.11 with the 'optimum' theoretical dimensions. It can be seen that the differences between the two are small.
- 2.7.7.12 The relative advantages and disadvantages of adopting either a linear or a shallow sawtooth stand can best be illustrated by a worked example given in Diagram 2.7.7.12. The designs are single bus stands that can accommodate the 12 m design bus under a one-way operation; and with intermediate pedestrian crossing facility at a maximum of every third stand around a pedestrian island.
- 2.7.7.13 For reference purpose, Table 2.7.7.13 shows the comparative platform lengths required for a given number of stands.

Table 2.7.7.13 Comparative Platform Length Requirements

No. of Stands	2	3	4	5	6	7	8	9	10	11
No. of Pedestrian Crossings			1	1	1	2	2	2	2	2
Sawtooth (m)	32	56.3	68.6	86.9	105.2	123.5	141.8	160.1	178.4	196.6
Total Length (m)	32	50.3	71.1	89.4	107.7	128.5	146.8	165.1	183.4	201.7
Linear (m)	36	60	84	108	132	156	180	204	225	234

- 2.7.7.14 It can be seen from Table 2.7.7.14 that for platform lengths yielding five to eight linear stands, an extra shallow sawtooth stand can be accommodated, with either a reduction in platform length or additional space for other facilities, whereas a linear platform of nine or more stands yields two additional shallow sawtooth stands.

DIAGRAM 2.7.7.3: DIMENSIONS FOR LINEAR BUS STANDS AND TEST RESULTS

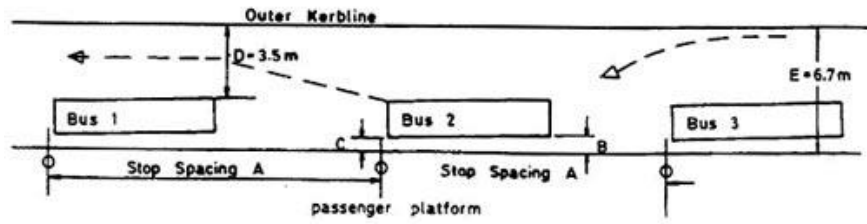

Dimensions (metres)	Test Numbers						
	1	2	3	4	5	6	7
Stop Spacing A	13.7	19.8	21.3	22.9	24	25.9	29
Rear End B	2.06	0.84	0.76	0.60	0.50	0.40	0.20
Front End C	0.23	0.38	0.46	0.18	0.15	0.15	0.20

Dimensions D and E remain fixed.

DIAGRAM 2.7.7.4: STANDARD DIMENSIONS FOR LINEAR BUS STANDS

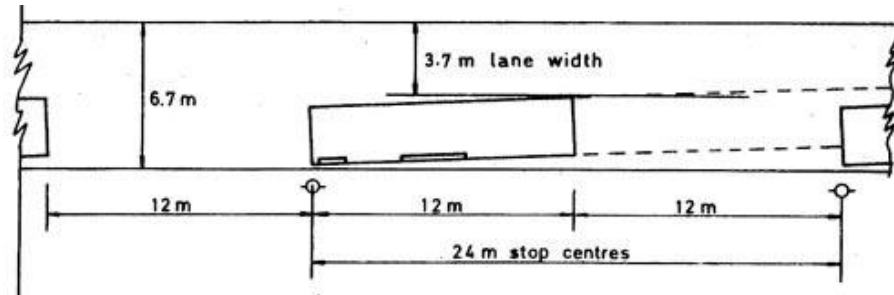

DIAGRAM 2.7.7.5: SAMPLE LAYOUT FOR SAWTOOTH BUS BAY AND PLATFORM

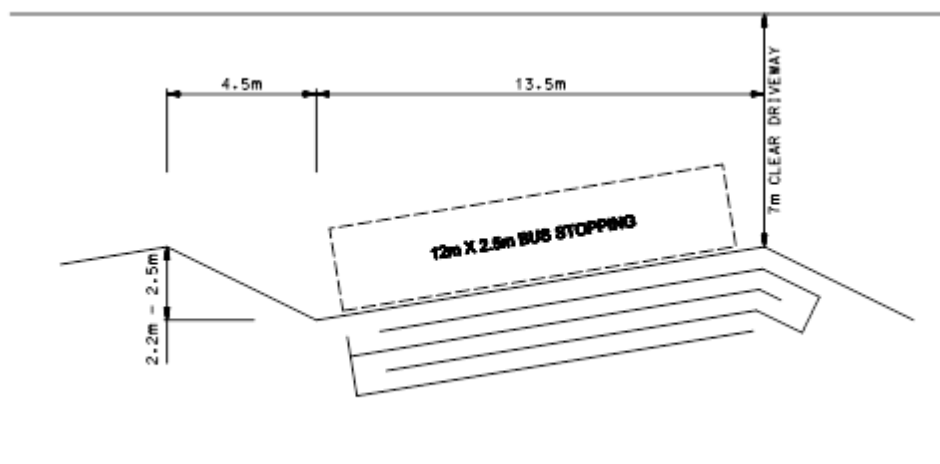
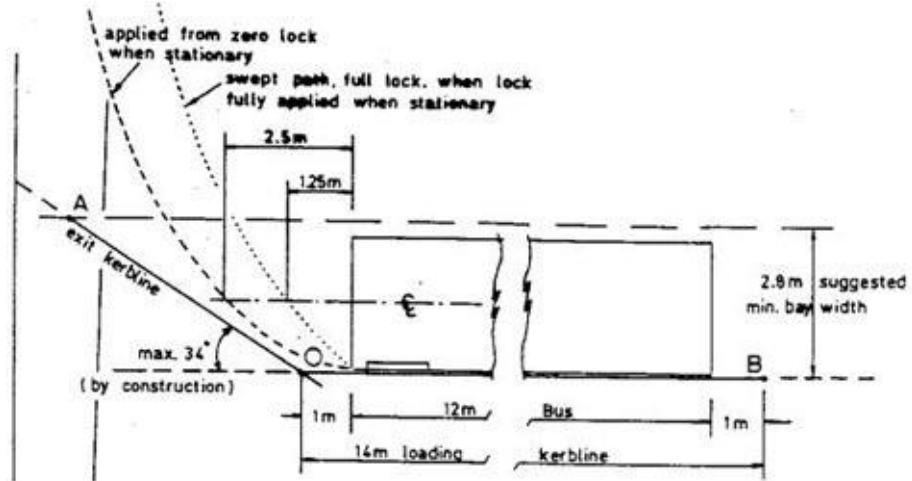

DIAGRAM 2.7.7.9: DERIVATION OF THE BASIC LAYOUT OF THE SHALLOW SAWTOOTH STAND

(A) Angle of exit kerbline in relation to loading kerbline



(B) derivation of dimensions for 'AB' parallel to platform spine

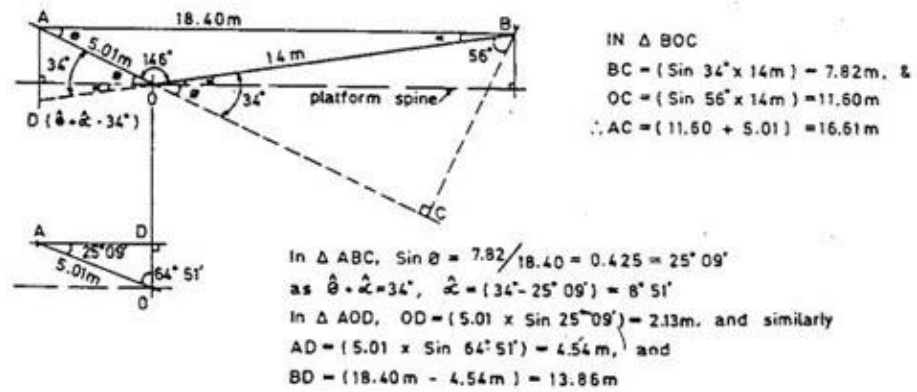
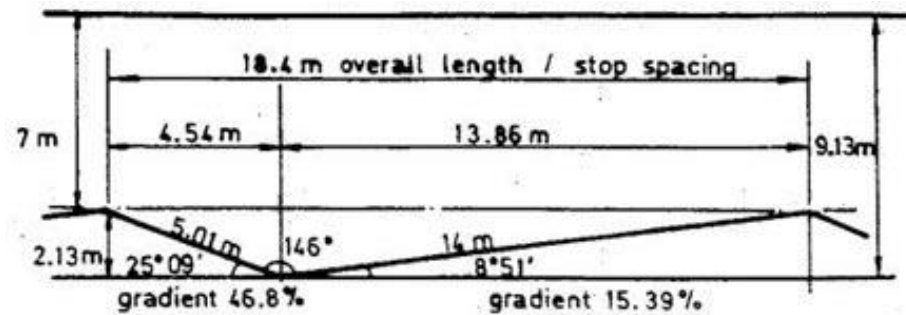

DIAGRAM 2.7.7.11: COMPARISON OF CALCULATED AND ACTUAL ARRANGEMENTS

(A) Optimum derived by calculation



(B) Derived by test

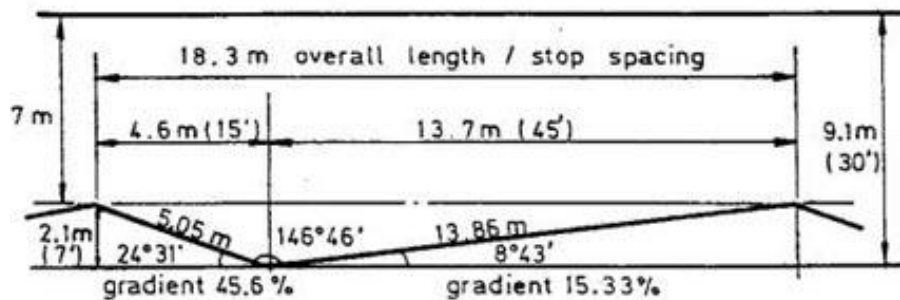
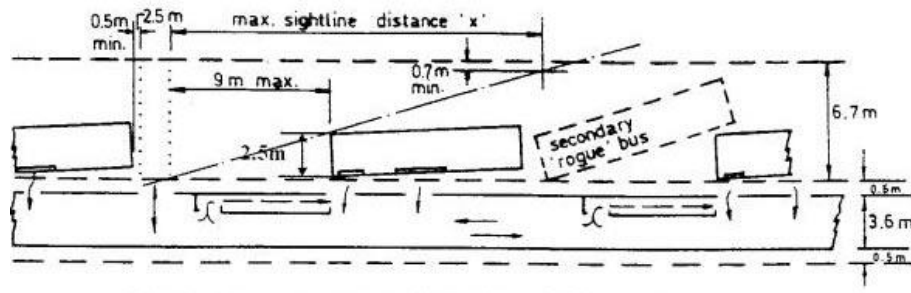

DIAGRAM 2.7.7.12: COMPARISON OF LINE AND SHALLOW SAWTOOTH STANDS

(A) Linear Stands



Sightline distance 'x' = $[9 \times (6.7-0.7) / 2.5] \text{m} = 21.6\text{m}$ maximum

(B) Shallow Sawtooth

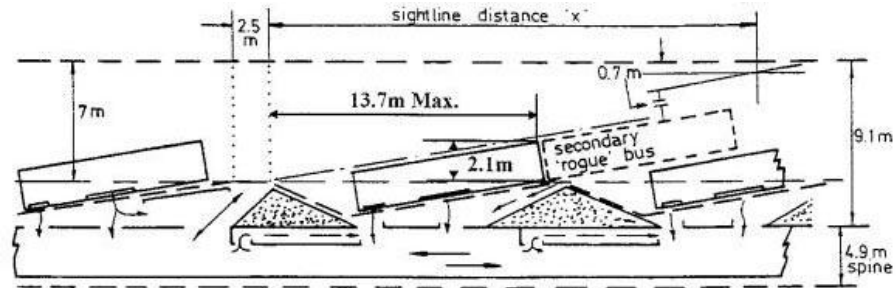

Sightline distance 'x' = $[13.7 \times (7.0-0.7) / 2.1] \text{m} = 41.1\text{m}$ minimum

2.7.7.15 For reference purpose, Table 2.7.7.15 shows the comparative widths required for linear and shallow sawtooth lanes :

Table 2.7.7.15 Comparative Lane Widths

No. of lanes	2	3	4	5	6
S. Sawtooth 14.0m	28	42	56	70	84.0 metres
Linear @ 11.6m	23.2	34.8	46.4	58	69.6 metres

2.7.7.16 It can be seen from Table 2.7.7.15 that there has to be sufficient site width to accommodate five shallow sawtooth lanes before an additional 6th linear lane can be introduced. If each of the 6 linear lanes yields 5 stands, site capacity = 30 stands, then each of the 5 sawtooth lanes yields 6 stands, site capacity = 30 stands or if each of the 6 linear lanes yields 9 stands, site capacity = 54 stands then each of the 5 sawtooth lanes yields 11 stands, site capacity = 55 stands.

2.7.7.17 Table 2.7.7.17 is derived from Table 2.7.7.13 and 2.7.7.15 and shows the area occupied per stand.

Table 2.7.7.17 Area Occupied by Different Number of Stands

No. of Stands	2	3	4	5	6	7	8	9	10
Linear Type (m2)	210.6	234.0	245.7	252.7	257.4	260.7	263.3	265.2	266.8
Sawtooth Type (including crossings) (m2)	224.0	234.7	248.9	250.3	251.3	257.0	256.9	256.8	256.8
Difference (m2)	+13.4	+0.7	+3.2	-2.4	-6.1	-3.7	-6.4	-8.4	-10.0
Difference per stand (m2)	+6.70	+0.23	+0.80	-0.48	-1.02	-0.53	-0.80	-0.93	-1.00

2.7.7.18 For platforms of between 2 and 4 stands, sawtooth arrangement occupies an average additional space of 2.6 m² per stand. As for platforms of between 5 and 10 stands, linear arrangement occupies an

average additional space of 0.8 m²per stand. It can therefore be seen that the comparative space requirements will vary according to the number of stands, platforms, and the overall site dimensions. If intermediate crossing points are not required, the advantage of the sawtooth layout are greater.

2.7.7.19 The advantage of the linear stand may be summarised as :-

- (i) A narrow overall width is required.
- (ii) The position of stands, and composition of single and double stands may be varied without physical changes to the kerbline.
- (iii) Intermediate pedestrian crossings may be added without increasing vehicle spacing.

2.7.7.20 The advantages of the shallow sawtooth stand may be summarised as:-

- (i) A shorter overall length is required, reducing walking distances by 25%.
- (ii) The reverse-curve approach path is eliminated, easing the driver's task and allowing the bus to park close to and parallel to the loading kerb, thus promoting easier and safer boarding and alighting. (NB - with a 200 mm kerb, the first step height is reduced to only a few centimetres)
- (iii) The straight approach path protects the platform structure from accidental damage, and reduces tyre wear. The structure and pedestrian zones can be further protected by safety rails or raised planting in the triangular 'pedestrian free' area.
- (iv) The area between loading kerb and platform structure forms 'pause zone' to assist alighting passengers to gather children and also allows safe egress from a secondary "rogue" bus.
- (v) A secondary bus will not block the passing lane (see Diagram 2.7.7.12).
- (vi) The sightline distance between approaching bus and pedestrian crossing is nearly twice that for a linear stand.
- (vii) The fluctuating width of the sawtooth platform enables additional features (e.g. storage areas, lift shaft, stairs) to be accommodated with little or no increase in platform width, a significant advantage where bus termini are part of multi-storey developments.

2.7.7.21 It will therefore be seen that the shallow sawtooth stand based around large passenger islands are preferable from a design point of view, particularly in the larger bus termini comprising 5-10 stands per passenger island. The design, where based around large passenger islands, will considerably improve the environment for the passenger, and increase the potential for reducing pedestrian vehicle conflict by reducing the number of access points to services. The advantages to the operator are that the terminal is more flexible in terms of the number of manoeuvres that can be conducted within it, will be more responsive to changes in the bus network, and will allow better marketing and regulation of services by concentrating them around a limited number of passenger islands. With reference to the advantage of shallow sawtooth stand as described in section 2.7.7.20, it is recommended that for new PTIs, it should adopt the sawtooth layout unless site configurations or constraints render such design unfeasible.

2.7.7.22 It should however be noted that the advantages generated by the shallow sawtooth stand only apply when there is sufficient demand to warrant the provision of more than 5 stands. There will also need to be a reasonably large site available to accommodate the greater space requirements of this design.

2.7.7.23 The possibility of designing shallow sawtooth single and double stands based around one or more central passenger islands should be given due consideration in the design of all bus termini.

- 2.7.7.24 The relative advantages of adopting the shallow sawtooth design in a 12 single stand bus terminus is shown in Diagrams 2.7.7.24 (A) and (B).
- 2.7.7.25 There will be many occasions where double shallow sawtooth bus stands are required and the general layout of these are shown in Diagram 2.7.7.25 (A), for the 12 metre design bus, retaining a shallow sawtooth zone depth of 2.1 metres and the single bus exit splay, with a loading kerb length of 26 metres.
- 2.7.7.26 In exceptional circumstances where the 12 metre design bus is considered to be inappropriate, the shallow sawtooth stand can be designed for specific vehicle lengths. A layout can be derived for any vehicle length by determining a stand length in relation to the bus length, the angle between the loading and exit kerblines and the bay width. Any reduction in the length of the stand kerb will produce corresponding reductions in the depth of the sawtooth zone, the carriageway width and the stop spacing. Diagram 2.7.7.25 (B) shows a shallow sawtooth for a 9.5 metre bus assuming an 11.5 m stand a 2.85 m bay and a valley angle of 146°.
- 2.7.7.27 To protect waiting passengers from exhaust emissions and heat, it is recommended that new PTIs should as far as applicable to have air-conditioned waiting areas. The criteria for provision of air-conditioned waiting area at PTIs includes the following:
- (i) The layout should either be central stacking with loading and unloading berths at the periphery of the PTI or central island passenger platform with all boarding and alighting activities at the island and stacking of buses at the periphery of the PTI.
 - (ii) Priority to be given to PTIs located at
 - (a) areas of high background pollution like Central, Admiralty, Wan Chai, Causeway Bay, Tsim Sha Tsui, Mong Kok, Kwai Chung, Tsuen Wan and Kwun Tong;
 - (b) at railway stations to encourage use of railway;
 - (c) at bus-to-bus interchanges to encourage interchange between buses;
 - (d) at tourist spots e.g. Disney Park, Tsim Sha Tsui, the Peak and Stanley to improve the image of the public transport facilities in the city;
 - (e) at housing estates where utilization is high; and
 - (f) at PTIs and BBIs where the design of which do not allow free air flow.
 - (iii) Priority should also be accorded to PTIs to integrate with air-conditioned surroundings like railway concourse and big shopping arcade.
 - (iv) If provided, the air-conditioned waiting area should be used by passengers on all PT modes using the PTI unless site constraints render this not feasible.

DIAGRAM 2.7.7.24: EXAMPLE OF A PREFERRED BUS STATION LAYOUTS

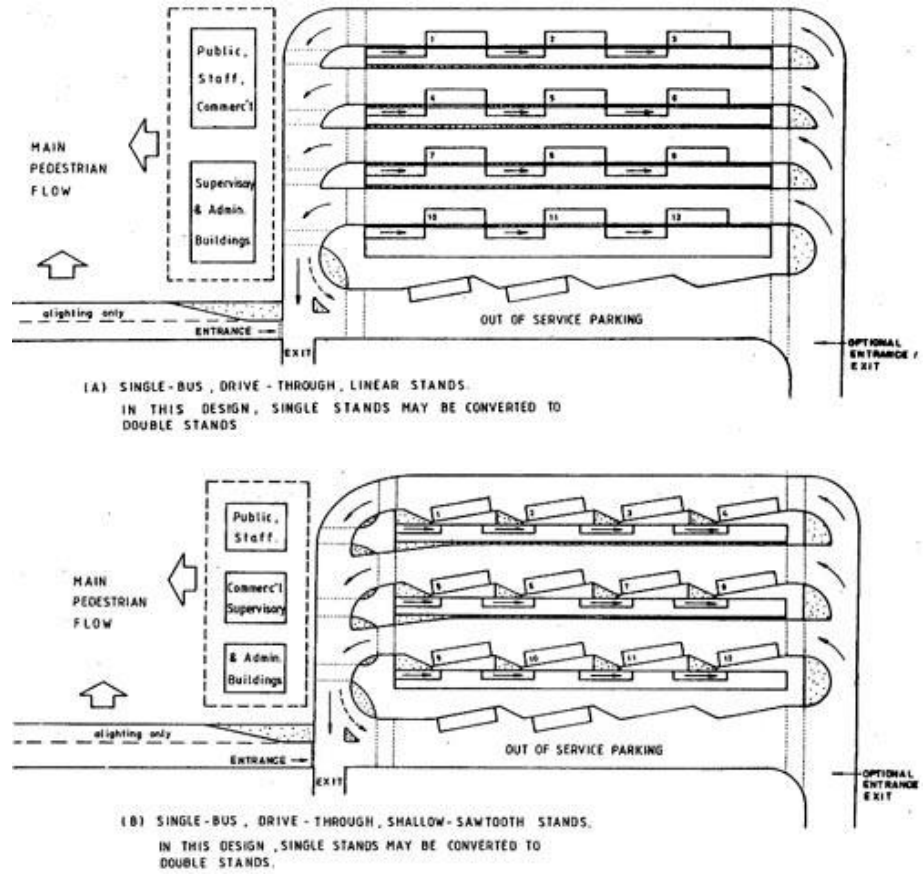
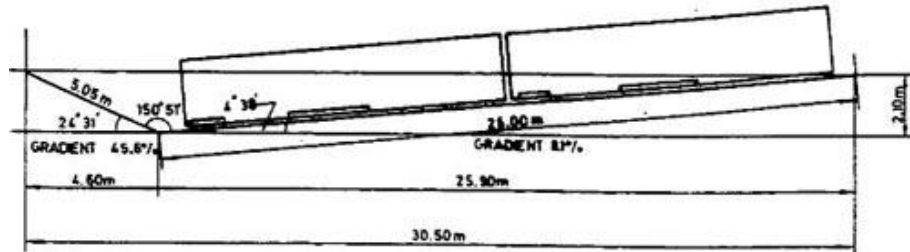
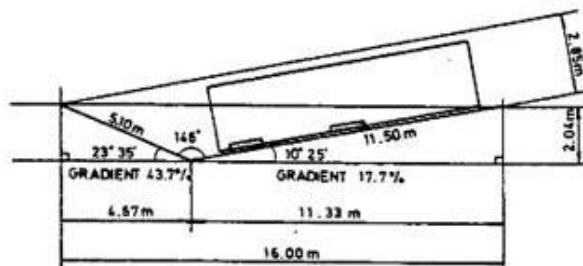

DIAGRAM 2.7.7.25: VARIATIONS ON STANDARD SINGLE SHALLOW SAWTOOTH SETTING OUT DETAIL

(A) Double bus stand on shallow sawtooth-12 metre vehicle



(B) Modified sawtooth dimensions for 9.5m vehicle



2.7.8 Lane Widths in Bus Termini

2.7.8.1 For linear stand bus termini, clear lane widths should be of a minimum of 7.3 metres. The clear lane width for sawtooth bus termini is 7.0m; and 9.2m to 9.5m when measured from the kerbline depending on the sawtooth angle. These dimensions are applicable where the nearside kerbline is straight. Where the carriageway is curved, allowance has to be made for the swept path of buses, based on the 3 axle Leyland Olympian or Volvo Olympian. As demonstrated in Table 2.7.8.2 the width of the swept path on full lock is more than twice the overall width of the vehicle. The lane widths shown are therefore recommended for use in bus termini for specific inside corner radii. Further lane widths can be derived by use of the formula depicted section 2.3.

2.7.8.2 It will be noted from Table 2.7.8.2 that the required lane widths increase substantially with decreasing values for r. This is due to the large swept path of the Leyland Olympian 3 axle bus and it is therefore desirable to keep the nearside radii within bus termini to a minimum of 10 metres.

Table 2.7.8.2 Minimum Lane Widths on Bends in Bus Termini

Internal Kerb Radius (metres)	Single (2) Lane (metres)	Double (2) Lane One or Two Way Operation
10	6.6	11.0
15	5.8	10.3
20	5.4	9.5
25	5.1	9.0
30	4.8	8.7
40	4.5	8.5
20	4.3	7.9
100	4.0	7.3
150	4.0	7.3
Straight (1)	4.0	7.3

Note (1) : Lane widths on the straight relate to linear bus termini, sawtooth widths require 7m of clear driveway.

Note (2) : Lane widths are for bus termini which are exclusively used by buses.

2.7.9 Entrances and Exits in Bus Termini

2.7.9.1 Entrances and exits to the bus terminus will need to be in accordance with the standard junction design for the road fronting the terminus. To achieve greater flexibility in bus route planning, full traffic movements should be allowed, wherever practicable, for entrances and exits to bus termini.

2.7.9.2 From bus operational point of view, it will be better to have the greater number of options that exist for approaching and departing from the bus terminus. Normally, the two separate 2-way entry/exit points represent the ideal situation. This presents the greatest possible level of flexibility, e.g. permitting the operation of both terminating and through services without the need to run several laps of the bus terminus. Separate accesses should be provided for franchised and non-franchised vehicles whenever practical, unless the site is too small or extensive land requirements would result. Separate access is also required for route to bicycle park, although this can be integrated with the footpath.

2.7.9.3 Conversely, where it is only possible or desirable to provide one combined entrance/exit, the shallow sawtooth/linear stand central island(s) type of bus terminus is an obvious attraction, as all turning manoeuvres are provided for off the highway (see Diagram 2.7.7.24). This is in contrast with the standard Hong Kong bus terminus arrangement, which in nearly all cases requires the provision of separate entrances/exits. If taxis or other vehicles are present, the design should ensure that tailing back from their picking up / setting down would not affect franchised bus operation.

2.7.9.4 In all cases, the arrangement of entrances and exits in relation to the immediate highway network should be in accordance with the general principles laid down in paragraphs 2.7.3.6 to 2.7.3.16.

2.7.10 Curved or Cranked Carriageways in Bus Termini

2.7.10.1 Although it is not recommended that bus stands be arranged around a cranked or curved carriageway, there may be instances where for space reasons this is unavoidable.

2.7.10.2 The following information has been derived by means of theoretical calculation rather than test and should therefore be regarded as advice only. Additionally, specific circumstances will have different solutions based upon individual sets of conditions such as the available carriageway width and radius in the case of curved carriageways. For cranked carriageways, the degree and position of the crank is also important.

2.7.10.3 In Diagram 2.7.10.3 (A) a 35° crank is shown on the external kerb, and it can be seen that the approach to stand 'E' is the critical factor, as the departure path from stand 'D' is easier than if tire relationship between stand 'D' and 'E' were straight, in that the normal reverse-curve exit path is virtually eliminated.

2.7.10.4 In this example, the exit kerb of stand 'D' has been produced through distance 'x' to a point from which the 35° crank can be set-out. This distance has been utilised to form a pedestrian crossing, and, by chance, has set the loading kerb of stand 'E' on almost the same alignment as the Stand 'D' exit kerb. Distance 'x' will have to increase as the angle-of-crank increases in order to produce a practical approach path to stand 'E'. It is also an advantage if distances 'Y' and 'Z' are multiples of the building module although, as a special unit has to be provided to accommodate the crank in the platform structure, it can also absorb any variation in the length of each leg.

2.7.10.5 With an internal crank as in Diagram 2.7.10.3 (B), it is the exit path from stand 'D' that is critical, having a worse reverse-curve manoeuvre than if straight. Stands 'D' and 'E' are therefore separated from the point-of-crank at distance 'x', which again will increase with the increase in the angle-of-crank, and the resultant kerb length has been used for pedestrian crossing purposes. Also, the comments above regarding dimensions 'x' and 'y' apply again here.

2.7.10.6 Diagram 2.7.10.3 (C) shows a curved platform on the external kerb. As with the external stands in the cranked situation, it is the approach to each stand which determines whether or not a layout is practical. Therefore, the larger the radius of the stand-line, the closer the layout approaches the basic straight-line arrangements, and, as above, the stands may be "hung" on the design radius as a series of chords, the length of which being the overall Length of the appropriate stand design.

- 2.7.10.7 Where the design radius 'r' is small, as in Diagram 2.7.10.3 (D), the arrangement departs more from the original, straight basis, and the overall stand length has to be increased in order to provide an adequate approach path. A radius R has been introduced which exceeds design radius r, and the appropriate stand detail has been set-out with the approach end on radius r and the departure end on radius R. The exit kerb has then been produced to intersect design radius r, thus increasing the stop spacing by distance 'x' and giving the opportunity for crossings at virtually every stand. The difference between radii R and r will have to increase as radius r decreases. In common with all designs on the external radius or crank, pedestrian/bus sightlines at crossing points are excellent.
- 2.7.10.8 Diagram 2.7.10.3 (E), shows a curved platform on the internal kerb. As with the internal stands in the cranked situation, it is the departure path from the proceeding stand that is critical and determines the practicality of a layout. As before, the larger the radius the closer the arrangement comes to the basic straight relationship. Again, the stands have been 'hung' from the design radius on chords equal to the overall length of the chosen stand design, and the pedestrian crossing points require additional platform length.
- 2.7.10.9 Where the design radius is small as in Diagram 2.7.10.3 (F), the overall stand length has to be increased to provide an acceptable departure path. The basic stand design can be 'hung' on the design radius but the depth of the stand has been taken from the design radius, not the chord, so that the indentation does not become unnecessarily deep and the relationship between the loading kerbs of adjacent stands do not become too severe. The stand length has been increased by distance 'x' and, as 'x' increases, the situation will be reached whereby the loading and exit kerbs share the same alignment and each stand becomes a simple chord. In common with all designs on the internal curve or crank, pedestrian/bus sightlines at crossing points tend to be poor.
- 2.7.10.10 All bus termini should be constructed with concrete carriageways to minimise maintenance costs and disruption, and to avoid deterioration from diesel and oil spillage.

DIAGRAM 2.7.10.3: CURVED AND CRANKED CARRIAGEWAYS-STAND LAYOUT

SCALE 1:500

(A) CRANK-EXTERNAL KERB

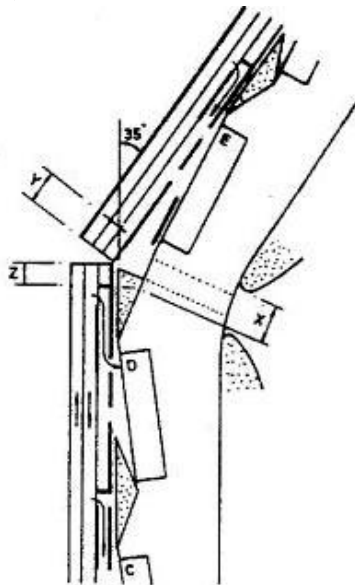

(B) CRANK-INTERNAL KERB

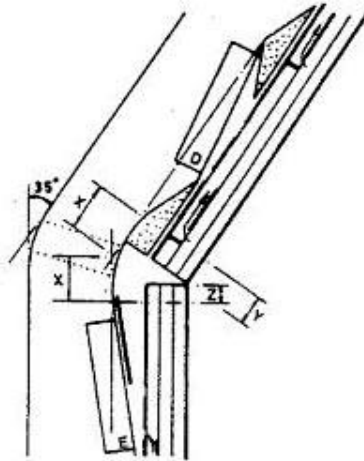

(C) CURVE-EXTERNAL KERB

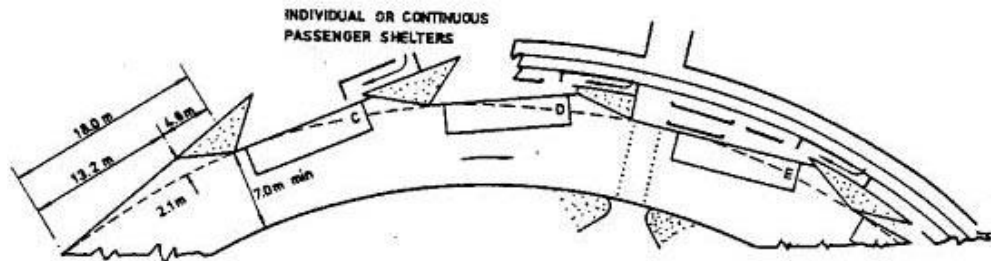

(D) CURVE EXTERNAL KERB SMALL RADIUS

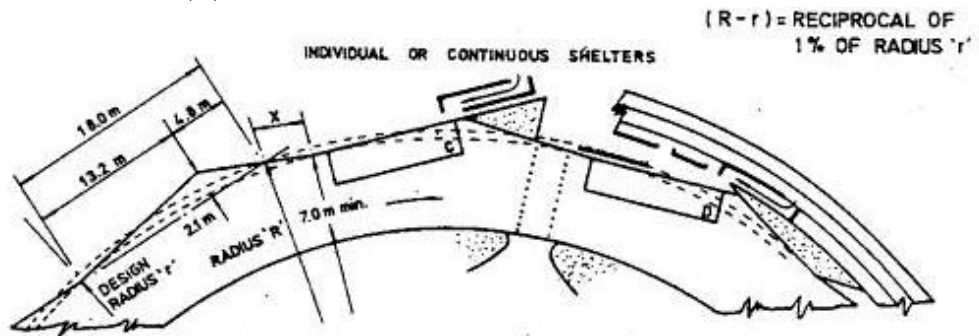

(E) CURVE-INTERNAL KERB

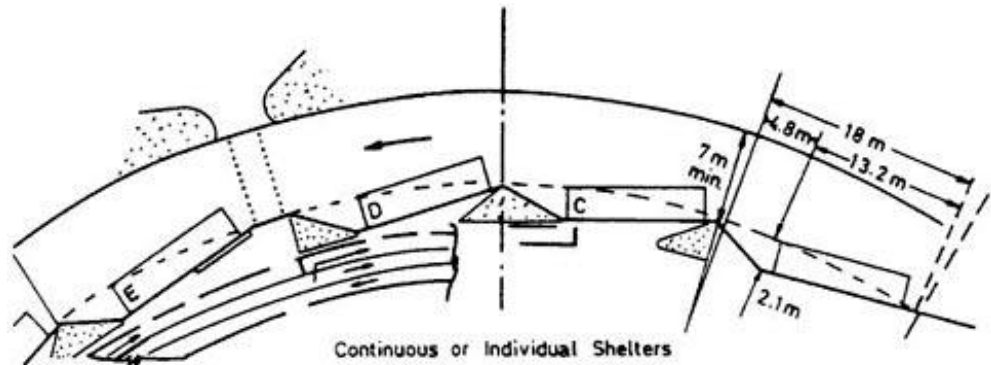

(F) CURVE-INTERNAL KERB, SMALL RADIUS

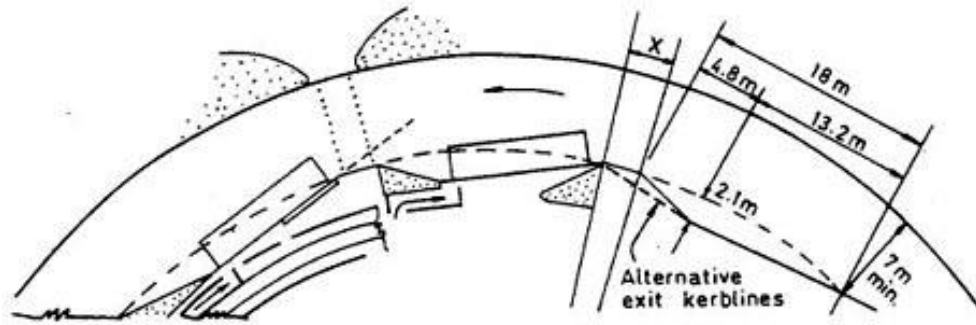

2.7.11 Operators' Requirements

- 2.7.11.1 Although some 'through' services may call at a bus terminus, most bus services are likely to terminate there. The facility should be capable of handling the required numbers of vehicles and passengers safely and efficiently at minimum cost.
- 2.7.11.2 In some designs, the same stands are used for both unloading and loading bus passengers. In other designs, passengers are set down at a common unloading point or area and buses then proceed to separate loading stands. Buses on terminating services are also required to take layover or to be parked for longer periods out of use or for driver meal breaks.
- 2.7.11.3 Buses should be able to enter and leave a bus terminus with minimum delay and without major detours from a direct route, especially in the case of through services where through passengers may be inconvenienced by long detours. Streams of arriving and departing buses should not conflict and there should be the minimum of conflicting moves within a bus terminus.
- 2.7.11.4 Other operators' requirements include toilet, rest facilities for bus operator's staff and Regulators' offices (staff ancillary facilities) should be treated as a standard requirement and as part and parcel of the bus terminal facilities. The facilities are required by bus operators to facilitate regulators (inspectors or duty despatchers) work at the major termini, as well as bus captains for reporting and taking duties and having meal and rest breaks at bus termini. The facilities are essential to bus operations and have to be provided.
- 2.7.11.5 Built-in structures for the staff ancillary facilities have to be provided in permanent bus termini with two or more bus bays. For bus termini provided for temporary use or roadside bus service terminal points with only one bus bay, enough space has to be reserved to facilitate bus operators to install their own facilities.
- 2.7.11.6 Since a bus terminus in Hong Kong normally accommodates two bus operators, there shall be adequate space of the staff ancillary facilities to facilitate the use of their staff. An area of 72m² is the reference areal for such facilities provision in bus termini with two to seven bus bays. For larger bus termini with eight or more bus bays, more space for staff rest area and toilets are required and the reference provision is increased to 80m². It is desirable wherever possible to further segregate the rest facilities into a rest area and a meal area. The main functional areas and breakdown for each functional part of the facilities in bus termini with different sizes are as follows:

Staff Ancillary Facilities		Area for bus termini with 2 – 7 bus bays (m ²)	Area for bus termini with 8 or more bus bays (m ²)
Regulator Offices with storage area		22	22
Staff Rest Area		34	40
Toilet	Male	8	8
	Female	4	6
	Disabled	4	4
Total		72	80

¹ The reference area of 72m² is provided for bus termini with two bus operators. For bus termini with only one operator or with three operators, the standard may be adjusted after consulting the Transport Department.

2.7.11.7 Subject to the site condition of each planned bus terminus, the built-in structure of the bus operators' staff ancillary facilities shall better be provided in an integrated structure and it shall be placed in a bus terminus with front side fixed with window and facing most bus bays for facilitating bus regulators to oversee the bus operations. The staff ancillary facilities shall be provided in a bare shell with water and electricity supply; data link and telephone line; lighting, ventilation system, fire services installation and sanitary fittings (urinal, water closet, and basin, etc.). Except for constructing partition wall for toilets and for separating each operator's accommodation, there shall be no partitions within the accommodation so that bus operators can arrange their own decoration for suiting their own needs. A sample layout of the staff ancillary facilities to be provided in a bus terminus is shown in Diagram 2.7.11.1.

DIAGRAM 2.7.11.1 SAMPLE LAYOUT OF STAFF ANCILLARY FACILITIES TO BE PROVIDED IN BUS TERMINI

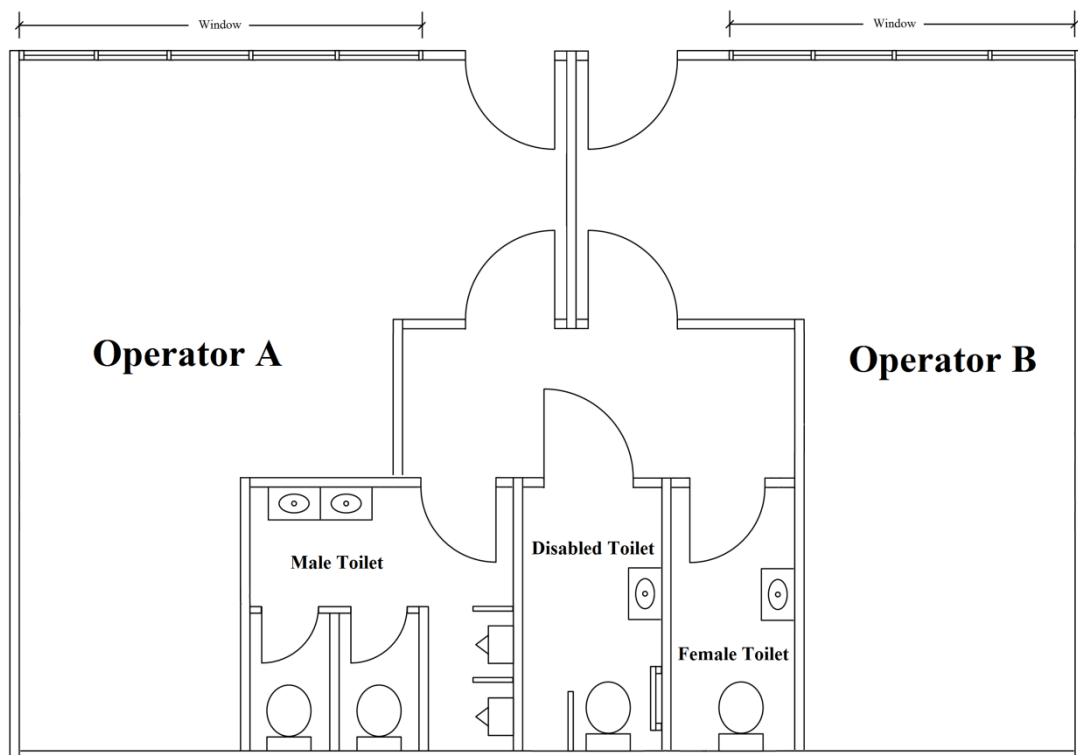

2.7.11.8 The Transport Department and bus operators should be consulted on the location and design of the staff ancillary facilities in the planning stage of bus termini.

2.7.11.9 To facilitate bus captains accessing the bus stacking areas, bus loading bays and staff ancillary facilities, crossing facilities should be included as appropriate in the planning stage of bus termini.

2.7.12 Passenger Facilities

2.7.12.1 Urban bus services are generally operated at high frequencies and hence the waiting time at bus termini should be minimal. As a result, only basic queuing facilities are required, with shelter where appropriate.

2.7.12.2 To upgrade the quality of bus services and maintain competitiveness with other modes, most bus operators are keen to provide more advanced passenger facilities.

2.7.12.3 From a passenger perspective, the general principles/guidelines for provision of passenger facilities at bus termini are summarised below. Although they can be used as a check list, it is not necessarily a list of essential requirements as they depend on the location, size, nature and surrounding environment of a bus

terminus:-

- (i) Integrated design of bus terminus;
- (ii) Minimisation of walking distances between services;
- (iii) Provision of column-free area for reducing obstruction to and enhancing safety of public transport operations (Departmental Circular No. 4/2020);
- (iv) Provision of travelators, lifts and escalators, and ramps for long walks, level differences and handicapped pedestrians respectively;
- (v) Provision of adequate pedestrian network with safe environment including adequate capacity and lighting, weather protection (air-conditioning and/or good ventilation), crossing facilities, minimisation of pedestrian-vehicular conflicts and personal security;
- (vi) Provision of congenial waiting environment with adequate capacity seating and quality information on services;
- (vii) Provision of facilities including kiosks, refreshment facilities, sales of smartcards and smarted added value machine, toilets, newsagents and retails;
- (viii) Provision of adequate directions for passengers, particularly first time passengers;
- (ix) Provision of on-line real time passenger information system;
- (x) Provision of staff and use of CCTV for information and security purposes;
- (xi) Use of raised platform at boarding point in association with low-floor buses with a kneeling facility; and
- (xii) Provision of adequate capacity for terminating and passing buses.

2.7.13 Pedestrian Routes

- 2.7.13.1 The primary consideration is to consider the needs of the pedestrian, both in terms of minimising the horizontal and vertical distances involved in walking to passenger objectives at nearby markets, shops, offices, schools, commercial and leisure facilities, and in terms of maximising his safety.
- 2.7.13.2 Special attention should be given to the design of pedestrian routes to and from the bus termini with the aim of segregating pedestrians and vehicles wherever possible. Ideally, the bus terminus should be connected to a comprehensive system of pedestrian ways giving safe, quick and covered access to adjacent facilities. This system should be enhanced by appropriate directional signing. In addition, all platforms inside the bus terminus should be accessible by wheelchair, which includes the provision of dropped kerbs of 1m width. Reference should also be made to Chapter 8 of Volume 6 on the design and provision of facilities for people with disabilities.
- 2.7.13.3 Within the bus terminus itself, the safety of the pedestrian is of paramount importance, particularly in those situations where bus and pedestrian flows are high and concentrated in a relatively small area. It is therefore desirable wherever possible to segregate these conflicting flows by providing pedestrian routes which are as safe and direct as possible. When designing the pedestrian crossing points, consideration should be given to the possible pedestrian movement within the bus terminus, such as pedestrian accesses to nearby amenities (e.g. markets, shops, offices, schools, commercial and leisure facilities), bus bays, and pick-up and drop-off points for public light buses and taxis. Raised platforms should also be provided at boarding points.
- 2.7.13.4 It is not desirable that passengers interchanging between services should be required to cross public roads at-grade or that they should be required to use open (unsheltered) walking routes. Segregation does not

necessarily mean the provision of subways or overbridges, as these tend to encourage unauthorised pedestrian movement on bus carriageways, causes hardship to the disabled, the elderly, and mothers with young children. Bus Termini can be built on a completely different concept with peripheral bus bays where bus passengers do not have to cross vehicular traffic at all.

- 2.7.13.5 Where at-grade crossing facilities are provided, the judicious use of barrier railing, raised areas, good signing and other physical features would encourage the pedestrians to use the authorised routes only. The sketch in Diagram 2.7.13.1 (A) shows a typical arrangement applicable to the shallow-sawtooth stand. Although the openings in the structure at each stand present an opportunity to cross the carriageway, this can be minimised with one-way platforms because there should be no corresponding opening on the other side of the carriageway. The arrangement shows the ideal exit layout where site length allows the buses to clear the Perimeter Crossing Point before the exit manoeuvre, thus divorcing the hazard of pedestrians from the exit turn whilst maintaining the footpath facility of the adjacent public highway. The Intermediate Crossing Point is shown at the suggested maximum of every third single-bus stand, or every other double bus stand.
- 2.7.13.6 All the crossing points can be highlighted with yellow striped marking and linked longitudinally by paved areas of a different colour texture to alighting areas and queue zones, in order to develop a network of authorised routes. In addition, each crossing point should be provided with drop-kerbs to ease the transition from footpath to carriageway.
- 2.7.13.7 Where the relative levels of a particular site lend themselves to the provision of subways or overbridges, or where escalators and lifts can be incorporated to supplement staircases then vertical segregation of vehicle and pedestrian routes may improve safety and ease of movement. However, to be successful such systems must be designed so that no alternative unauthorised routes exist across vehicle carriageways. Further, adequate provision must always be included for the disabled, elderly, and mothers with children.
- 2.7.13.8 The sketch in Diagram 2.7.13.1 (B) shows a lift and escalator in relation to a minimum width platform. Some surface crossings may still be required for emergency situations when power supplies are affected, but these should be closed off during normal operation.

DIAGRAM 2.7.13.1: HORIZONTAL AND VERTICAL PEDESTRIAN FACILITIES IN BUS TERMINI

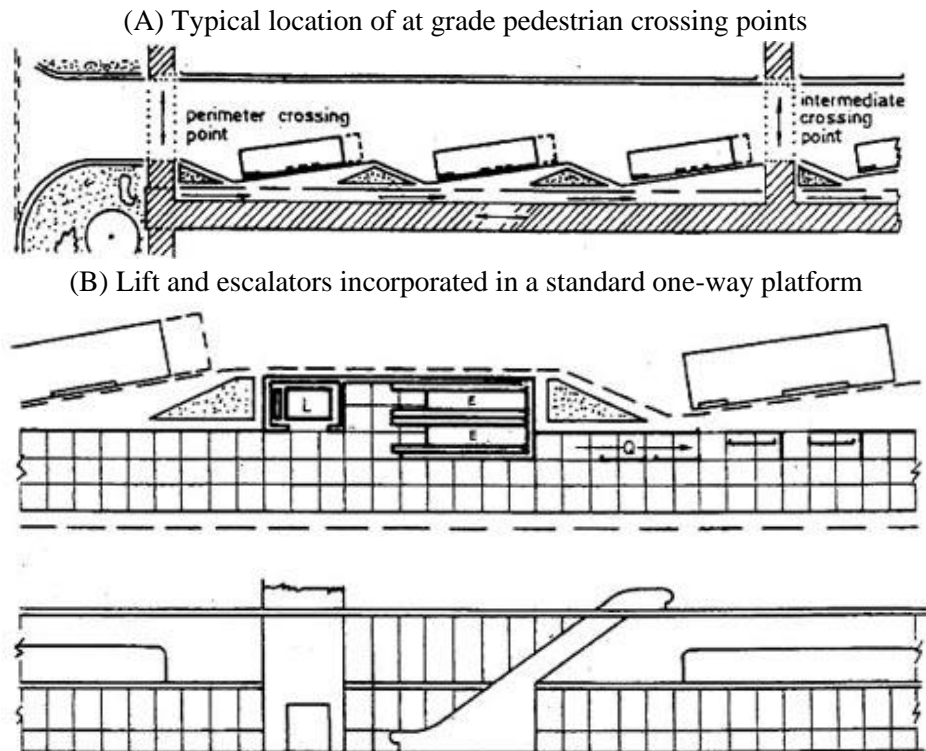

2.7.14 Passenger Queuing and Circulation Areas

- 2.7.14.1 Passenger queuing and circulation areas should be based around one or two-way island platforms with careful segregation of queuing and walking lanes.
- 2.7.14.2 Diagram 2.7.14.2 (A) shows setting out details for shelters aligned longitudinally along a one-way island spine around shallow sawtooth stands. Shelter lengths and capacities can be increased to suit double-bus stands and if the overall stand lengths and pedestrian crossing widths are compatible with the longitudinal shelter module, the individual shelters may be linked together at a future date, thus forming continuous cover for pedestrians.
- 2.7.14.3 Diagram 2.7.14.2 (B) shows the two-way arrangement based upon (A) and upon 1.016 metres wide shelters. Despite the fact that pinch-points only occur at shelter positions, it can be deemed necessary to add a third pedestrian lane in view of the extra passenger traffic generated by twice the number of stands, but this has been ignored for comparative purposes, which results in a 1.5 metres saving in width per two-way platform.
- 2.7.14.4 Diagram 2.7.14.4 (A) shows continuous, fully enclosed shelters based upon the standard 1.2 metres modular grid, with spine-edge set-backs in excess of the 0.5 metres minimum, for an extra margin of safety between carriageway and structure, and to bring spine and sawtooth zone to around 7 metres overall width, thus producing a 14 metres wide lane of 2 x 7 metres bands.
- 2.7.14.5 The layout for a two-way platform with continuous shelters is shown in Diagram 2.7.14.4 (B). Again, the possible third pedestrian lane has been omitted and the two-way layout shows a width-saving over the one-way layout, in this case some 1.9 metres.
- 2.7.14.6 Two-way platforms can not only double the number of bus stands giving better interchange opportunities, but also, if the third pedestrian lane is omitted, show a reasonable saving in the required overall width. However, they also produce pedestrian crossings with a minimum length of 14 metres, plus two directional bus flows for the pedestrian to contend with. Pedestrian refuges will be required for such crossings which may produce a central reservation effect and this negates the advantage of the initial reduction in width. This requirement for refuges can have further detrimental effects at the entrance/exits

to the bus station, particularly if the traffic flow on the adjacent highway is one-way, as indicated in Diagram 2.7.14.6.

- 2.7.14.7 It will be noted that a minimum of 1 metre is recommended for passenger lanes and queuing zones, whilst the standard shelter module shown produces alternatives of 1.016m or 1.525m.
- 2.7.14.8 Queuing arrangements within the islands should be such that passengers face the approaching bus (Standard Queue) so that passengers may identify the service as early as possible, have more time to prepare for boarding, and improve safety. Also passengers alighting from both the front and central doors have a direct and unobstructed path to the covered area and the general pedestrian circulation lanes, see Diagram 2.7.14.8 (A).
- 2.7.14.9 Queues with their backs to the approaching bus (Reverse Queues) as in Diagram 2.7.14.8 (B) have none of the above advantages, and have the added disadvantage of forcing centre-exit passengers to either conflict with boarding passengers or to pass behind the queue zone which is unsatisfactory particularly if the pedestrian focal point is on the left-hand side of the stand. These problems are further compounded at double-bus stands with longer queue zones.
- 2.7.14.10 However, Reverse-queues can be tolerated in certain circumstances such as when the last stand only is reversed in order to make the best use of the available platform length Diagram 2.7.14.8 (C) and where perimeter pedestrian crossings are not required across the carriageway in question.
- 2.7.14.11 Having located the queue zone in relation to the structure, the area can be completed by the addition of a series of in-lane standard barrier rail units over the required length of the queue zone. As an alternative to the standard queue rail these could be of a simple design with a top horizontal rail only and gaps of 0.4 to 0.6 metres, similar to the amenity barriers provided on-street, so that :
- (i) in emergency, passengers may vacate the queue area as easily as possible;
 - (ii) any pedestrian, particularly the elderly or infirm, when approaching a short queue from the boarding end, may join the queue without being obliged to walk the full length of the queue zone; and
 - (iii) passengers in the queue who wish to board a related-service bus at an adjacent stand, may vacate the queue zone with as little disruption as possible. This can be important at double-bus stands where intending passengers have a choice of services using the stand.

However, in most situations queue railing of the more traditional design is considered to be most appropriate.

- 2.7.14.12 Wherever possible, all stands should have the same queue capacity, (double-bus stands having a correspondingly higher capacity) in order to permit as much flexibility as possible for the future relocation of services within the bus station. Where the majority of pedestrian movement is expected to occur to and from one particular end of a platform, there is a tendency to allocate the more heavily-utilised services to this particular end of the platform, quite reasonably, to reduce the walking-distance for the majority of passengers. However, if this arrangement is likely to produce concentrations of passengers which in turn will disrupt operations, some consideration should be given to spreading the services and passenger densities more evenly over the platform length.
- 2.7.14.13 Where a double-bus stand caters for several related services and when two buses appear at the stand at virtually the same time, the situation will arise where there will be at least two streams of alighting passengers and two streams of boarding passengers flowing simultaneously as in Diagram 2.7.14.13. Such occurrences may not be unusual in the Territory and the resulting conflict and confusion is common place. Diagram 2.7.14.13 (C) shows various ways of catering for this movement, in an attempt to improve upon the situation shown in Diagram 2.7.14.13 (A).

- 2.7.14.14 Generally, platform structures that follow the shape of the shallow sawtooth stand are not recommended in that they are more expensive than a straight structure, are more exposed to accidental collision damage, the structure may mask pedestrians when approaching a crossing point, and the zigzag of queue zones which follow this shape may confuse passengers. However, it may enable a narrower platform to be accommodated where site widths are restricted. A typical arrangement of this nature is shown in Diagram 2.7.14.13 (B) for a one-way platform, which demonstrates that such a layout is only acceptable for low shelter capacities, and hence is liable to be of limited application in the Territory, although the queue overflow area provides useful additional space, albeit for queuing in a fairly disorganised manner. The arrangement is therefore not recommended.
- 2.7.14.15 The sketches in Diagram 2.7.14.13 (B) to (E) show some of the alternative possible arrangements for the combined boarding and alighting stand, for both single and double bus capacities, on shallow sawtooth platforms for one-way operation and with continuous platform structures based on the 1.2 metre module.
- 2.7.14.16 Theoretical capacities of the queue zones are shown in parenthesis and are based on a crush capacity of 5 persons per 1.2m square grid. Additional areas designated 'S' could be used to provide seating, litter receptacles, or other passenger facilities. It will be seen that the queuing capacities compare favourably with that provided in the traditional linear arrangement. In this example, a crush capacity of 4 persons per 1.020m has been taken.
- 2.7.14.17 Peak queue lengths may exceed this number, particularly if the bus terminus is served by many through services which may be partly full on arrival. If more than the above quoted figure required to be accommodated, their only choice is to queue on the carriageway. With the examples shown in Diagram 2.7.14.13 (D) and (E) queuing capacities of around 210 passengers can be accommodated per double stand and around 90 per single stand. More importantly, any overspill can be accommodated on the central island spine.
- 2.7.14.18 These capacities can be further increased if a separate alighting stand is provided, thus negating the need to provide for alighting passengers on the stand. In all the arrangements shown in Diagram 2.7.14.13, provision has been made for boarding and alighting from front entrance, centre exit buses, thereby making it possible to cater for both terminating and through services.
- 2.7.14.19 In addition to the queue and barrier railing shown, there is scope for the addition of seating, litter bins, lighting, and passenger service information. Seating should only be provided on the lower frequency stands, if considered to be desirable. Further enhancement of the waiting environment may be achieved off the main passenger islands by the addition of toilets, kiosks and landscaping where appropriate.
- 2.7.14.20 It can be reasonably argued that the bigger the bus terminus, the greater the extent the principles / guidelines should be met. What is more important is their interpretation and application. It is considered necessary that a design brief is the first prerequisite for the planning and design of a bus terminus. In preparing such a brief, the location, size, nature and surrounding environment of a bus terminus will have to be carefully considered together with an assessment of volumes of passengers / pedestrians and their associated needs.
- 2.7.14.21 Volume 9 Chapter 8 of the Transport Planning and Design Manual should also be referred when designing the passenger queuing and circulation areas.

DIAGRAM 2.7.14.2: ONE AND TWO WAY PLATFORMS ON CENTRAL ISLAND SPINES WITH INDIVIDUAL SHELTERS

(A) ONE-WAY PLATFORMS WITH INDIVIDUAL SHELTERS

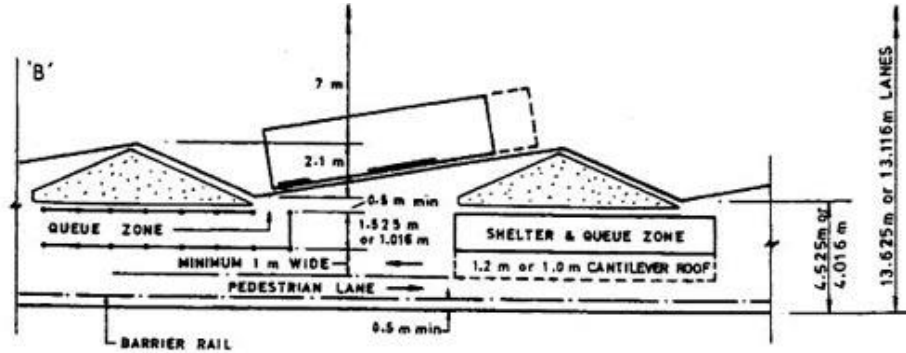

(B) TWO WAY PLATFORMS WITH INDIVIDUAL SHELTERS

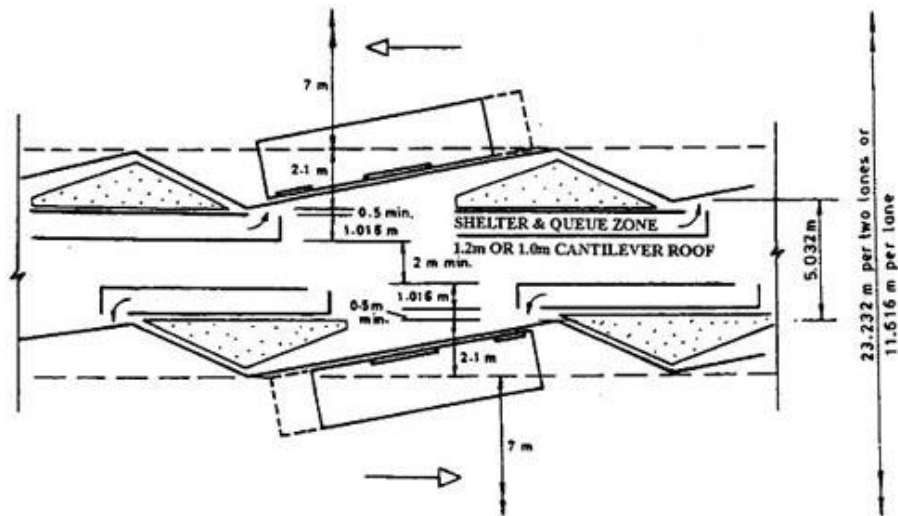
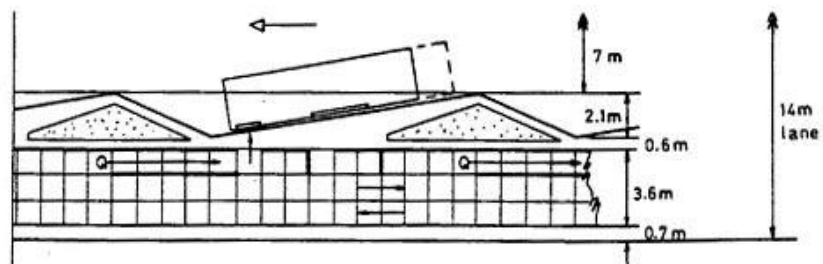

DIAGRAM 2.7.14.4: ONE AND TWO WAY PLATFORMS ON CENTRAL ISLAND SPINES WITH CONTINUOUS SHELTERS

(A) One-way platform with continuous shelters



(B) Two-way platform with continuous shelters

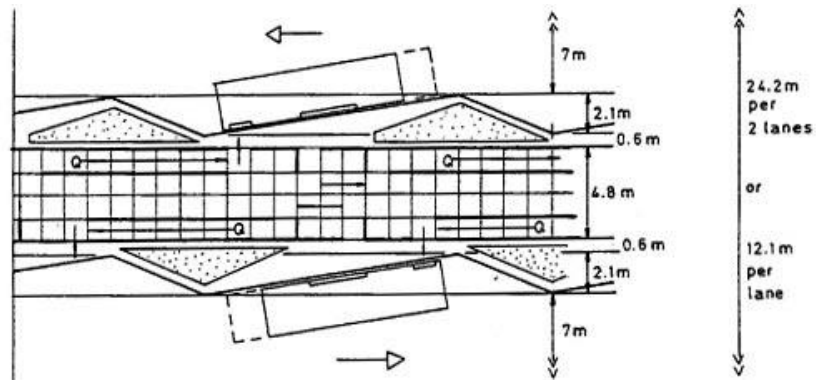

DIAGRAM 2.7.14.6: ENTRANCE/EXIT PATHS FROM TWO-WAY BUS STATION LANES

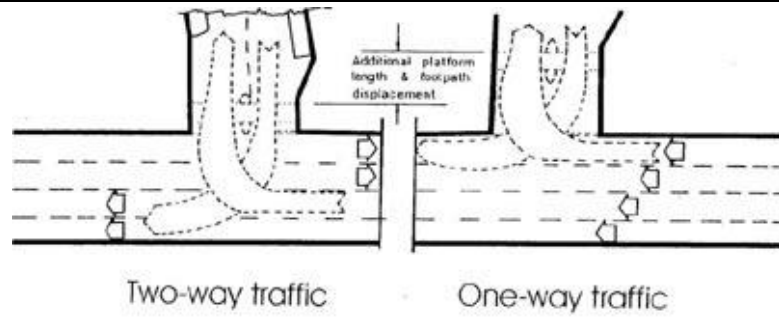

DIAGRAM 2.7.14.8: ALTERNATIVE PASSENGER QUEUING ARRANGEMENTS

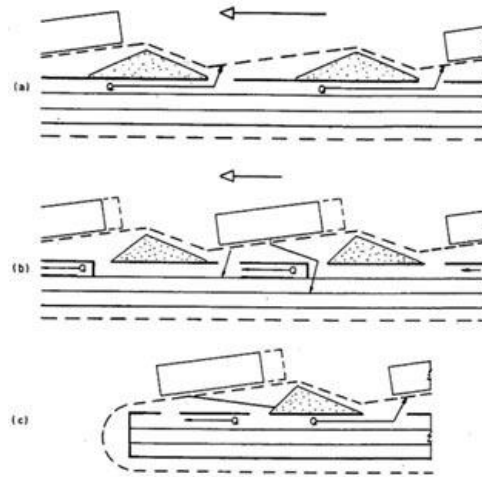
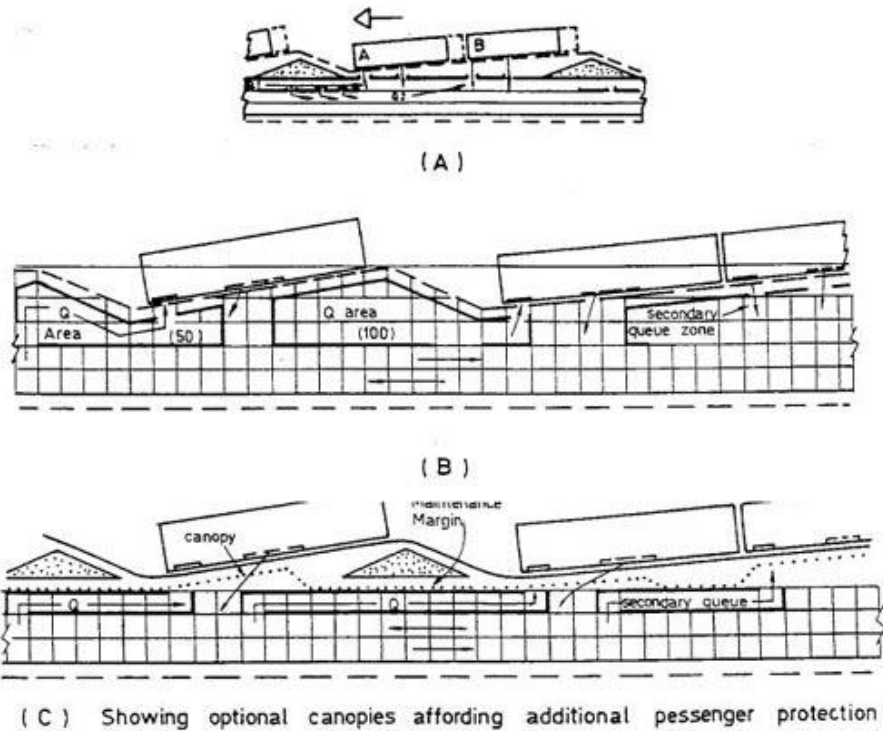
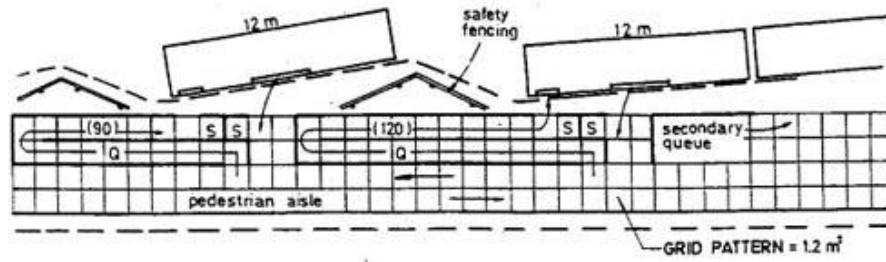

DIAGRAM 2.7.14.13: ALTERNATIVE PASSENGER QUEUING ARRANGEMENTS



Scheme (D) with double width queue zones



Scheme (E) alternative to (D) showing "split-queue" for double-bus stand service groups

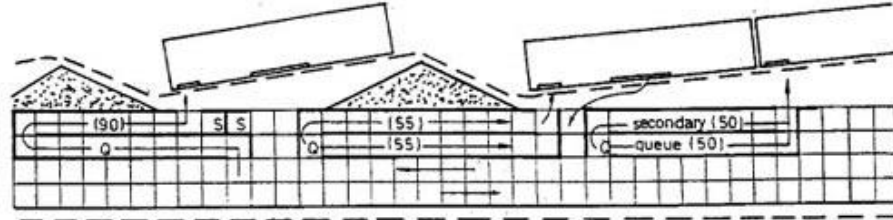

Scheme (F)

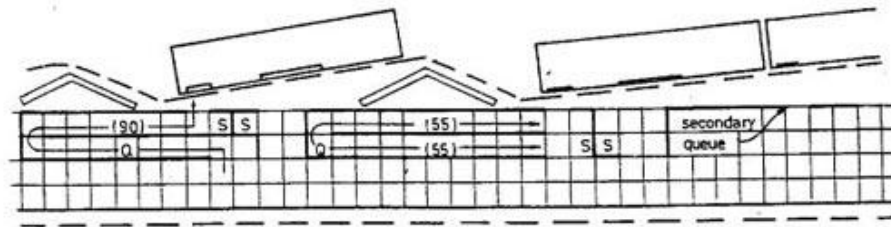

S: LOCAL SEATING OR LITTER BINS OR OTHER PASSENGER FACILITY.

2.8 Built Over Bus Termini

2.8.1 Introduction

2.8.1.1 Bus termini by their nature are usually sited on high value city centre land, and this may lead to consideration of more intensive use of the site by building over the bus terminus, either for car parking, shopping, offices, or other appropriate uses. While such multi-purpose developments are quite common and practicable in Hong Kong, there are a number of major factors which must be evaluated, and which may militate against the economic viability of the project.

2.8.2 Structural Grid Systems

2.8.2.1 One of the most significant problems is developing a structural grid system that is capable of accommodating the recommended platform module. Although there are a number of systems that are available, for the purposes of illustration a 1.2m square grid system has been adopted as there are several areas available on the shallow-sawtooth platform where relatively small structural members such as columns or stanchions may be easily accommodated, particularly in the layouts with wider platforms. There may however be problems in developing an economical and acceptable grid for major structural columns. It is virtually impossible to produce a square grid, and an optimum grid system has to be determined for each individual layout, and may require the layout to be modified to achieve compatibility with the platform module, or vice versa.

2.8.2.2 The sketch in Diagram 2.8.3.1 shows a simple layout of single-bus stands on one-way platforms of minimum width and with a platform structure based on the 1.2 metre module. This arrangement assumes that the columns have a maximum size in the order of 0.5 metres, at least in the latitudinal direction. The 14 metres primary span keeps the structural members out of the area of the platform structure, which is still required to provide an acceptable passenger environment.

2.8.2.3 However, there are many variables to be considered when developing a structural grid, including:-

- (i) the dimensions of the shallow sawtooth bays to be used;
- (ii) the relationship to any nodular platform structure;
- (iii) the width of the platform and the carriageway;
- (iv) whether the carriageways are to be one-way or two-way;
- (v) the positions of pedestrian crossing points;
- (vi) staircase, escalator, or lift zones; and
- (vii) the column-free area which is for reducing obstruction to and enhancing safety of public transport operations (Departmental Circular No. 4/2020).

2.8.2.4 Some existing built-over bus termini are designed within an irregular structural grid system where the bus stands have been fitted in around the available space, thus producing a poor passenger waiting environment.

2.8.3 Headroom Clearance

2.8.3.1 The TD minimum standard of 5.1 metres applies only to the new structures over public highways. A much larger area such as a built-over bus station needs a much greater clearance, not only for aesthetic reasons, but to allow a bus to be jacked up in case of accident, and to permit the recovery of broken-down vehicles by use of a tow truck and to allow the design of more economical lighting systems.

2.8.3.2 The height of the structure can be further affected by the need for a service zone above a suspended ceiling, particularly if a mechanical ventilation system is required, as indicated in Diagram 2.8.3.2. In order to account for such variables and achieve better ventilation, a clearance of 6 m is required.

DIAGRAM 2.8.3.1: STRUCTURAL GRID FOR ONE-WAY SAWTOOTH PLATFORMS

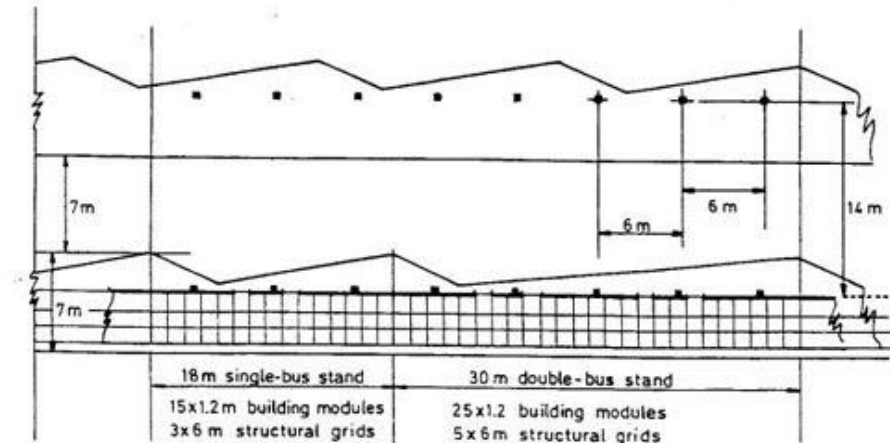
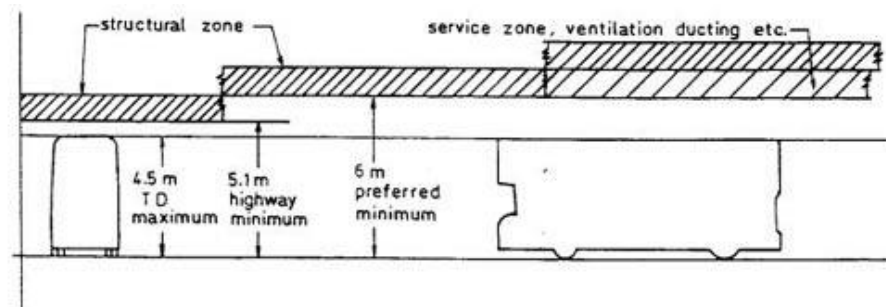

DIAGRAM 2.8.3.2: HEADROOM REQUIREMENT IN COVERED BUS TERMINUS



2.8.4 Ventilation

2.8.4.1 In designing the ventilation system, the Practice Note (PN) for Professional Persons on Control of Air Pollution issued by EPD in 1998 and 2022 should be reviewed. For new public transport interchanges with design (including the layout and ventilation system) already finalised at the time of issuance of PN 1/22 on 30 December 2022, the PN 1/98 shall continue to apply..

2.8.5 Drainage

2.8.5.1 Although under cover, an extensive drainage system is required for water carried in by vehicles, cleaning of platform structures, bursts, and for the cleaning of the carriageway areas. As there is no natural precipitation to help clear oil and grease deposits, and as exhaust fumes can fall on cold, damp days and produce a dangerous slimy film on carriageways, the carriageways may require cleaning as often as those bus garages. This requires large volumes of water and may dictate the use of a mechanical scrubber with the associated garaging facilities within the bus station.

2.8.5.2 The drainage system may also require the provision of petrol and grease interceptors, and, in common with all bus stations, the drainage gullies should be located on the opposite side of the carriageways from the loading kerbs.

2.8.6 Lighting

- 2.8.6.1 During daylight hours, lighting is required over both the passenger and carriageway areas of the covered bus terminus. The carriageway lighting in particular will have to be at its brightest on a sunny day as the level of lighting must be as near as possible the same on the inside as on the outside, there being no time to allow the eyes of the incoming driver to adjust to a lower intensity.
- 2.8.6.2 During the hour of darkness, however, the demands made on both the passenger and carriageway systems are identical and apply whether the bus station is open or built-over. Both systems will become fully operational at or before dusk until such time as services cease and the terminus is no longer manned, at which point both systems may revert to a lower intensity.
- 2.8.6.3 The specification for the lighting system shall comply with the Public Lighting Design Manual and should be decided in consultation with the Lighting Division of the Highways Department.

2.8.7 Maintenance

- 2.8.7.1 In addition to the normal maintenance requirements for an open bus terminus, the built-over bus terminus has further requirements for the cleaning of the carriageway, the maintenance of the ceiling lighting system, and mechanical ventilation system, and the repair, cleaning and decoration of the structure above and around the bus station.
- 2.8.7.2 In view of the primary function of the bus terminus, most of these activities would have to take place outside the peak operating periods, and may have to be confined to the costly, non-operational period during the early hours of the day.

2.9 Bus Depots

2.9.1 General

2.9.1.1 The total fleet of the 5 major franchised bus companies is 5,998 buses at end 1999. To maintain buses properly, the bus companies require depot facilities to support their operation. The purpose of this section is to set out the planning consideration and design guidelines for bus depots.

2.9.2 Policy Background

2.9.2.1 Prior to the 1980s, franchised bus companies built permanent multi-storey depots on land purchased in the open market and land acquired under private treaty grants. Under the old Profit Control Schemes (PCS), a bus company was permitted to earn a return up to a specified percentage of its Average Net Fixed Assets (ANFA). As the value of these depots was included in the company's ANFA, there was incentive for franchised bus companies to acquire land and build multi-storey depots.

2.9.2.2 Since the 1980s, land became increasingly expensive. In order to reduce the pressure on bus fares, it became the Government's policy to provide the bus companies with Short Term Tenancy (STT) sites to build temporary single-storey depots with minimum construction. Under this policy, the bus companies did not plan for depots beyond 4 or 5 years. With the misapplication of the PCS in the 1990s, there is even less incentive for the bus companies to build permanent depots. On the other hand, the heavy reliance on STT sites has led to problem: the frequent need to relocate from one site to another has resulted in hassles as well as extra expenses. Valuable land is not well utilized, and, as more sites are developed, it has become increasingly difficult to find replacements STT sites.

2.9.2.3 In August 1997, the following policy in respect of planning of bus depots was adopted by the Government:-

- (i) Suitable sites would be designated as "bus depots" on permanent basis;
- (ii) Sites earmarked as "bus depots" would be granted to operators in the form of short leases co-terminus with their franchise. Bus operators will be required to pay rental but not premium (or only nominal premium) so that they may be entitled to reimbursement for elderly concessions; and
- (iii) Use of the depot sites should be maximized.

2.9.2.4 Under this policy, bus operators are expected to draw up longer term depot plans (more than 5 years) and to build more multi-storey depots.

2.9.3 Existing Depot Needs

2.9.3.1 At present, 5 main types of activities are carried out at bus depots :

- (i) nightly servicing;
- (ii) overnight parking;
- (iii) minor repair and monthly inspection;
- (iv) major maintenance; and
- (v) body building.

2.9.3.2 In addition, bus depots are places where drivers report for duty at the beginning of their shifts, and receive briefings before the start of services. Sometimes, the top floor of the depots are used as an off-road driving school during daytime and for parking at night.

2.9.3.3 The details of the major activities are summarised below:

- (i) **Nightly servicing, overnight parking, minor repair and monthly inspection**
 Nightly servicing includes coin collection, refuelling, washing and minor repairs. Refuelling and repairs require ground floor space because fuel tanks and maintenance bays have to be provided, and have to be covered. Coin collection and bus cleaning can be carried out on upper floors. However, for efficient depot operation, nightly servicing is best carried out on a line basis with coin collection being done first or concurrently with refuelling and followed by bus washing. For planning purposes, a depot should be able to service 35% of the scheduled requirement within the peak hour between midnight and 1 am.
 Overnight parking can be accommodated on the upper floor of buildings. It does not have to take up ground floor space. It does not have to be covered. For efficient operations, overnight parking should be located in the same depot as, or close to, nightly servicing.
 Monthly inspections are carried out on buses usually in the same depots where nightly servicing take place. Monthly inspections involve the use of the pits and hence ground floor space. Pits have to be covered.
- (ii) **Major maintenance**
 Major maintenance includes Certificate of Road Worthiness (COR) which is required annually and Certificate of Fitness (COF) which is carried out at the ages of 10, 14 and 17 years and non-scheduled major repair/maintenance. These are Government's requirements under the Road Traffic Ordinance. Major maintenance involves the use of pits and hence ground floor space, although some workshop activities can be carried out on upper floors. Major maintenance has to be covered.
 COR/COF facilities are only required on a "regional" basis. They can be located relatively far away from the catchment areas. They can usually be accommodated within the servicing and parking depots.
- (iii) **Body-building**
 Body-building means adding of the bus frame and body panels to the chassis to form a bus. As the franchised bus routes expand, the fleet grows; hence there is an on-going need for body-building depots. Body-building does not involve the use of pits, but requires scaffolding and cover.
 Body-building can be provided far away from the operator's catchment area, even across the boundary.
- (iv) **Special needs**
 In addition, operators of long routes require depots at both ends of the route, in order to avoid the need to despatch empty buses over a long distance to operate the early morning

and late night trips. Typical examples are solely operated cross-harbour routes and routes between Chek Lap Kok and the urban areas.

2.9.3.4 Diagram 2.9.3.4 indicates the location of depots for the bus companies.

DIAGRAM 2.9.3.4: EXISTING DEPOT LOCATION



2.9.4 Territory Wide Planning Consideration

2.9.4.1 Bus depots should be provided in accordance with Section 19 of the Public Bus Services Ordinance on a regional basis to facilitate the building of bus body, repair and maintenance of buses and their parking when not in operation.

2.9.4.2 On the basis of existing distribution of depots, the long term needs of the bus industry and other policy and planning considerations, the territory can be divided into 14 “depot areas” as given below and each bus operator would require a depot for nightly servicing and overnight parking to support their bus fleet. For example, a major operator in NT & Kowloon such as KMB would need at least one temporary (STT)/permanent depot in each of eight depot areas in NT & Kowloon. At present, KMB has more than one depot in some of these depot areas, mainly because the sites provided are too small and are on STT basis.

2.9.4.3 An estimate of the long term needs of the 6 bus franchisees in each of the 14 depot areas in the territory is shown in Table 2.9.4.3.

Table 2.9.4.3 Long Term Depot Requirements (as at 31 December 1999)

District	Depot Areas	Existing Operators					Long Win	New Operator (Kai Tak Redevelopment)
		KMB	Citybus (HKI franchise)	(CLK franchise)	NWFB	NLB		
NT	Tseung Kwan O	N(1S/P)))	N(1S)))	
	Sha Tin & MOS	N (IP))))))	
	Tai Po & North	N(1S/P))))))	
	Yuen Long & TSW	N(4S/P)))))	D	
	Tuen Mun	N (3P) (1S))))))	
	Kwai Tsing & Tsuen Wan	N (1P) (1S))))))	
	Kowloon W	N (1P) (2S))))))	
	Kowloon E	N (2P))))))	N
	HKE)	N (2S))	D	N (1P) (2S)))
	HKI	HKW	D	D))	D (1S))
	HKS)	N (3S)))	N (1P) (2S)))
	Lantau S)))))	N (2S))
Lantau	Lantau N))	N (1S/P))	N (1S)	N (1S/P))
	Lantau W))	N (1S/P))	D	N (1S/P))

Note:

N – necessary to have at least one depot in these areas.

D – desirable to have a depot in these areas.

() Depot provision as at March 2000 is given in brackets. P denotes permanent depot.

S denotes STT depot.

2.9.4.4

In some of the depot areas mentioned in Section 2.9.4.3, existing operators have already built multi-storey depots which are sufficient for their needs in the foreseeable future. For permanent sites earmarked for depot use, TD is considering with operators concerned a phased programme for constructing multi-storey depots. To make up the shortfall of depot facility in adjacent area, TD has

requested KMB to examine more intensive multi-storey development of some sites, e.g. in West Kowloon Reclamation to make up the shortfall in Kwai Tsing.

2.9.4.5 In other areas, there is a need for additional depot sites to be identified for existing operators to meet their expansion needs or as replacement for STT sites which they will be required to give up, and for new operators to be brought into the market.

2.9.5 Local Planning Consideration

2.9.5.1 In addition to the territory wide planning consideration as described in section 2.9.4, the following local planning consideration should also be taken into account:

- (i) bus depots should be on level terrain with suitable vehicular access to the road system;
- (ii) the site should preferably be of regular shape;
- (iii) depot sites should be located in the areas where bus activities would not cause nuisance to residents, e.g. industrial areas;
- (iv) depot should be centrally located in relation to bus termini to enable dead mileage to be minimized;
- (v) depot should be located where they are readily accessible to supporting services such as tankers from oil suppliers, and
- (vi) the siting of bus depots should take into account the environmental intrusion that may result from 24-hour operation of maintenance and repair activity.

2.9.6 Responsibility of Site Search

2.9.6.1 The Planning Department is responsible for co-ordinating and conducting all permanent sites searches at the request of policy bureau and departments. Policy bureau or departments should complete a Site Search Form and forward the completed Site Search Form to -

- (i) Chief Town Planner/Standards and Studies if the proposed facilities are of territorial/sub-regional significance (e.g. gas production plant, zoos, tertiary education institutions, vehicle emission, testing centres); or
- (ii) respective District Planning Officers if there is a district locational requirement for the facilities or if the facilities are of a local nature.

2.9.6.2 To ensure optimum site utilization, policy bureaus or department should copy their requests for site searches to the Government Property Agency (Attn. Chief Property Manager, Estate Development Division) and the Architectural Services Department (Attn. Chief Architect/CMB) for consideration at the same time when they forward the requests to the Planning Department.

2.9.6.3 If the search for a site is for temporary use, the client bureau or department should forward its request (also in the form of a completed Site Search Form) to the relevant District Lands Office of the Lands Department and copy the request to the Government Property Agency and the Architectural Services Department.

2.9.7 Guidelines in the Design of Depots

2.9.7.1 This section is to provide the design guidelines for development of bus depot. These include:

- (i) Area of depot
The size of a depot in terms of gross floor area depends very much on the size of the fleet to be serviced. In terms of site area, the current policy is to encourage multi-storey depot development on permanent sites provided there is no undue pressure on bus fares. Partly

22m and an inner swept path of diameter of 13m should be adopted.

- (e) To accommodate these dimensions, driveways from which buses reverse into parking bays must be at least 12m in width. One-way driveways should be at least 6m in width, and two-way driveways should be at least 8m in width.
- (f) Ramp gradients should ideally not exceed 10% but greater is possible if site constraints offer no alternative.

2.9.8 Sample Layout

- 2.9.8.1 As an example, a layout for a 500 bus depot is to be drawn up. Assuming a young fleet and efficient practices, a maintenance space requirement equal to 10% of the fleet is required, ie., 50 spaces. Thus 450 buses should be in service each day.
- 2.9.8.2 It will also be assumed that about 35% of the fleet return to the depot for nightly servicing in the peak one hour ending 1 am. Thus about 158 buses are to be serviced. Assuming each line can handle 40 buses per hour there would be a need for 4 lines of refuelling and bus washing. The layout for conventional pumps is shown in Drawing 2.9.8.2.
- 2.9.8.3 A schematic layout showing a general ground floor layout which provides this capacity is shown in Drawing 2.9.8.3. In addition to the bus areas shown there would be a need for workshops and stores, staff roistering areas and offices, canteens, etc. These have not been shown as their location would depend on the site layout. The buildable area required for this layout is $75\text{m} \times 125\text{m} = 9,375\text{m}^2$ and therefore the site area would need to be over $10,000\text{m}^2$ if allowable coverage was about 90%.
- 2.9.8.4 Drawing 2.9.8.4 shows a schematic upper floor layout used purely for parking. It can be seen that the site dimensions provide a layout which is absolutely ideal with all three driveways being double loaded to provide six rows of parking. A total of 100 parking spaces can be provided on each floor and so, if there were no available terminus parking, a total of five parking floors would be required to fully accommodate the fleet. Thus the depot configuration would be Ground +1+2+3+4+Roof.

**DIAGRAM 2.9.8.2: NIGHTLY SERVICING AREA
(WEST KOWLOON RECLAMATION PROPOSED NEW BUS DEPOT)**

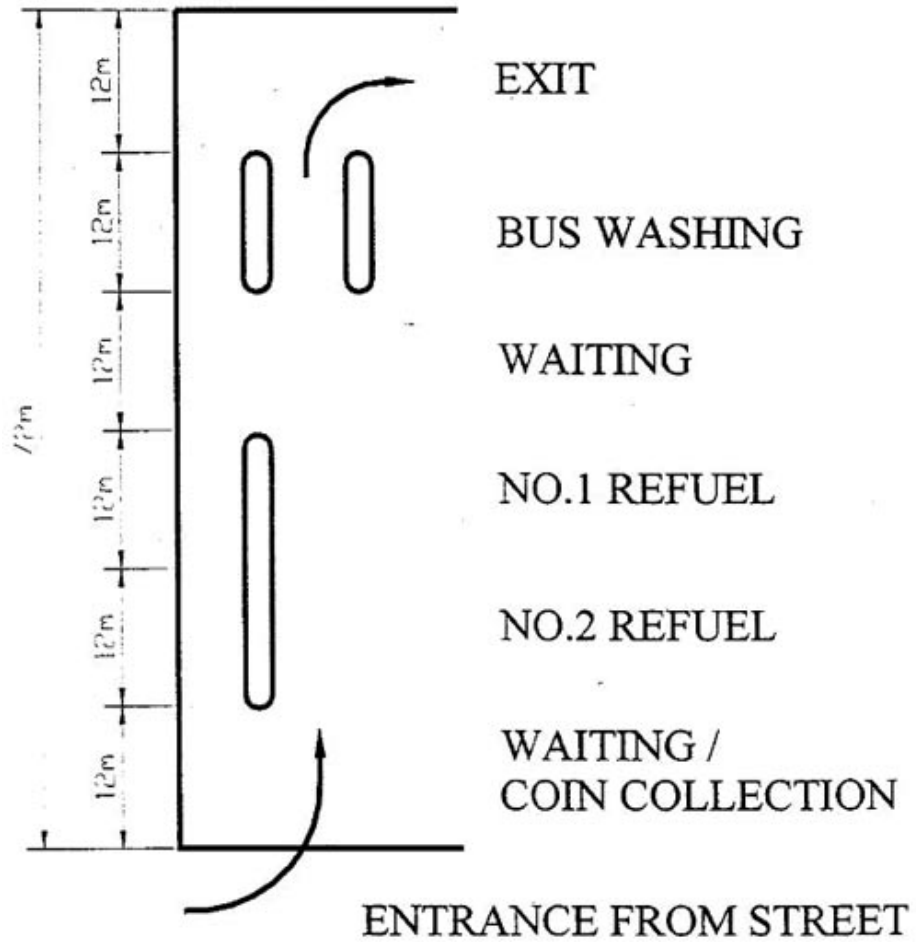

**DIAGRAM 2.9.8.3: GROUND FLOOR LAYOUT
(PROPOSED NEW BUS DEPOT)**

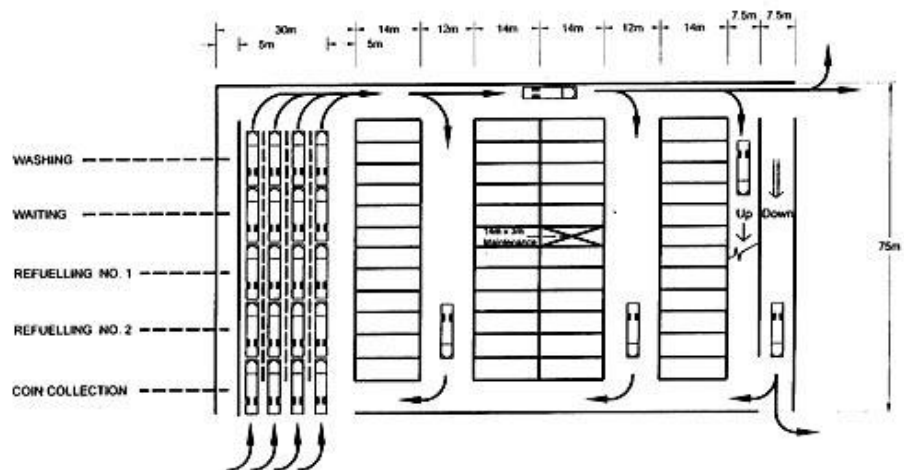
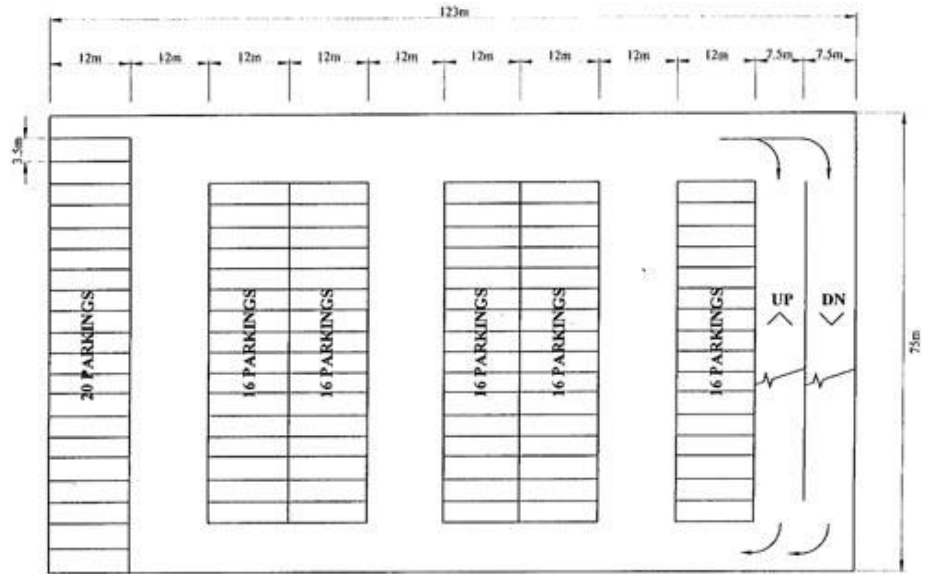

DIAGRAM 2.9.8.4: UPPER ELOORLAYOUT
(PROPOSED NEW BUS DEPOT)



TPDM Volume 9 Chapter 3 – Public Light Buses

3.1 References

- 1 Road Traffic Ordinance, Cap. 374
- 2 Road Traffic (Construction and Maintenance of Vehicles) Regulations
- 3 Road Traffic (Public Service Vehicles) Regulations
- 4 Road Traffic (Registration and Licensing of Vehicles) Regulations
- 5 Road Traffic (Traffic Control) Regulations
- 6 White Paper on Internal Transport Policy, May 1979
- 7 Departmental Instructions, Chapter 2, Traffic Management
- 8 TAC Report of Public Light Bus Policy Review, June 1997

3.2 Introduction

- 3.2.1 Public Light buses (PLBs) were introduced in 1969 to regulate the illegal minibus trade at that time. All PLBs are operated under passenger service licences issued by the Commissioner for Transport. There are two types of PLB operations: Red Minibuses (RMBs) and Green Minibuses (GMBs).
- 3.2.2 RMBs operate on non-scheduled routes in response to market demands and provide an alternative service for people. They are not required to operate on fixed routes or timetables and they are subject to certain restrictions on service areas
- 3.2.3 GMBs were introduced in 1972 through the conversion of RMBs. They operate scheduled services with fixed routeings, fares, vehicle allocation and timetables stipulated by Transport Department. Their primary function is to provide supplementary transport services along routes which do not justify a normal franchised bus service or in areas where access by other modes of public transport is limited.
- 3.2.4 The maximum dimensions of a light bus including PLB as stipulated under the First Schedule to Road Traffic (Construction and Maintenance of Vehicles) Regulations (Cap. 374A) are as follows, except permitted in writing by the Commissioner for Transport (effective from 5 July 2020):
overall length 7.5 metres*
overall width 2.3 metres
overall height 3.0 metres
- 3.2.5 It is stipulated in Section 2 of the Road Traffic Ordinance (Cap. 374) and the Second Schedule to the Road Traffic (Construction and Maintenance of Vehicles) Regulations (Cap. 374A) that the permitted gross vehicle weight (GVW) of a PLB should not exceed 8.5 tonnes except permitted in writing by the Commissioner for Transport (effective from 5 July 2020).

*The vehicle length of the existing low-floor wheelchair-accessible PLBs deployed for operation is around 8.0 metres.

3.3 Policy Guidelines

3.3.1 With the rapid development of high capacity carriers, PLBs has been performing a supplementary role in the provision of public transport services. The Government's policy is to limit their total number and maintain their level of activities. In gist -

- (i) the PLB fleet has been frozen at 4,350 since 1976 by an order of the Executive Council which was extended from time to time through resolutions made by the Legislative Council;
- (ii) PLBs are encouraged to operate scheduled services in the form of GMBs through the conversion of RMBs. GMBs may operate in new towns and on expressways;and
- (iii) RMBs may operate in existing service areas but not in new towns or new housing developments, and there are restrictions on RMBs using expressways.

3.3.2 The policy on PLBs was reviewed and reaffirmed by the Transport Advisory Committee in its 1997 PLB Policy Review. In term of the role and function of PLBs, the report pointed out that:

- (i) the primary function of PLBs to supplement the mass carriers should be maintained, in particular GMBs should play an important role in linking up new towns and villages with railway stations and bus termini, and in providing services to areas where patronage does not justify the provision of high capacity modes or where bus services are not economical or constrained by road terrain;
- (ii) RMBs are not allowed to operate in new towns because apart from being less efficient road users, their aggressive manner of stopping and waiting for passengers at kerbside and at road junctions is one of the main causes of traffic congestion/problems;
- (iii) local stopping restrictions should continue to be imposed to relieve traffic problems caused by RMB activities; and
- (iv) it is desirable to convert more RMBs to GMBs.

3.4 Public Light Bus (Scheduled) Services - Green Minibuses

3.4.1 Criteria for determining green minibus routes

3.4.1.1 The basic objective of providing GMB services is to supplement the mass carriers in the public transport system. Opportunities for planning new GMB routes may arise from identifying gaps in the network, or ranges of public transport services. Network gaps may include areas where mass carriers like franchised buses and railways cannot physically or economically operate or where there is a market for a higher quality service, which can be met by a green minibus route.

3.4.1.2 For route planning purpose, new GMB routes can be considered:

- (i) where the infrastructure is inaccessible to franchised buses;
- (ii) where the demand is insufficient to warrant franchised bus services;
- (iii) where there is demand for a higher quality transport service;
- (iv) a new GMB route should avoid duplicating an existing franchised bus or GMB route as far as possible; and
- (v) traffic impact should be assessed arising from the new GMB route which should avoid busy and congested areas as far as possible; and
- (vi) each package of GMB routes should be viable.

3.4.1.3 Opportunities for planning new GMB routes include:

- (i) to replace loss-making bus routes;
- (ii) to replace service provided by goods vehicles with excess passenger permits (EPP);
- (iii) to meet demand where bus services provided are inadequate and an increase of bus allocation would not be cost-effective; and
- (iv) to provide high-frequency feeder routes to railway stations or centers of activity.

3.4.2 Planning and design of green minibus routes

3.4.2.1 The above criteria provide the framework for designing new green minibus routes. Potential new routes can be identified from the following sources:

- (i) suggestions from members of public either directly to Transport Department or through other channels like the news media, other government agencies such as the Transport Complaints Unit;
- (ii) suggestions from District Council members made on behalf of their constituencies or Area Committees;
- (iii) suggestions from public transport operators including proposals from public light bus operators;
- (iv) traffic and transport studies and surveys;
- (v) review of bus route development programme items which call for substitution of unprofitable franchised bus services by green minibuses;

- (vi) programme for substituting rural routes operated by goods vehicles with excess passenger permits; and
- (vii) new land use/housing developments both in the public and private sectors, and new temporary housing proposals.

3.4.2.2 The next step is to determine the operational feasibility of the proposed new routes. Further examinations including visits on site may be conducted with respect to :-

- (i) best routeing in terms of patronage and under prevailing traffic conditions. Past experience indicates that short and direct routes, in particular those feeding to major transport interchanges, are the most viable routes. It should also be noted that the overlapping sections of green minibus routes may create uneconomic over-capacity and should be avoided;
- (ii) terminal points/turn around area : whether a proper PLB stand can be designated and if not, what alternative arrangements can be made, e.g. operate as a circular route with layover at only one end;
- (iii) major picking up/setting down points and arrangements to cater for these, e.g. exemption from stopping restrictions;
- (iv) journey distance of the route which will determine fare (the approved maximum scale of fares for green minibuses is distance-related);
- (v) basic frequency, which may be determined from an estimate of peak hour demand. Where the intention is to replace an existing bus route, the peak hour passenger demand for the bus service can be taken as a guide, and likewise in the case for replacing an EPP service. Where the proposed route is intended as the sole public transport service for a development, the peak demand can be estimated from the planned population using peak hour trip generation rates derived from appropriate transport studies;
- (vi) round trip journey time, which may be obtained through actual measurement along the route with due allowance made for en-route stopping. Alternatively, journey time may be assessed from available data of relevant journey time surveys;
- (vii) vehicle requirement, which is calculated as :-

$$\frac{\text{round trip journey time} + \text{layover time}}{\text{basic frequency}}$$
 where the layover time can be taken as 1/6 of the journey time;
- (viii) operating periods : whether the service is operated daily, or on certain days, or just over-night should depend on the requirement of the local environment for which the route is intended to serve; and
- (ix) prohibition/restrictions of public light buses required to protect the economic viability of the proposed green-minibus route and to reduce conflict between the two especially in the use of stands.

3.4.2.3 The next step is to formulate package of routes which is usually done on geographical basis. The concept of cross-subsidization may be adopted to ensure financial viability. It is common practice to group one or more profitable route(s) with one or more unprofitable but socially desirable route(s) together as a package.

3.4.2.4 Consultations with interested parties will be needed and the procedures laid down in para. 3.2 of the Departmental Instructions, Chapter 3 should be followed. The Police Traffic Headquarters, in particular, should be consulted where routes would involve sensitive areas, such as the Frontier District, or where there is

likely to be a reaction from existing operators. The consultations may subsequently lead to revision of the original proposals. Test runs may be conducted to resolve and differences in opinion before proposals are finalized.

3.5 Public Light Bus Stands and Termini

3.5.1 In places where there is high demand for public light bus services, the designation of public light bus stand will provide terminal facility for either RMBs or GMBs to stand and pick up/set down passengers, and will help both passengers and vehicles to form queues, leading to better order of kerbside activities. The facilities, however, should be provided in such a way that RMB and GMB activities are segregated.

3.5.2 The siting of a PLB stand is dependent on traffic demand, passenger convenience, environmental and traffic management considerations. It should as far as possible be designed to segregate PLB movement from other traffic, and should preferably be provided off-street in main commuter corridors. Accordingly, in assessing the suitability of the site, attention should be paid to the following aspects:

- (i) The stand should be designated at a location convenient to passengers.
- (ii) The stand should be sited at an appropriate distance away from road junctions, bends, bus stops and zebra and signal controlled crossings. On street locations should preferably be located in side streets to avoid causing congestion on main roads. Kerbside activities, their need and routeing in the area should be taken into account in determining a suitable arrangement for the stand.
- (iii) The stand should be provided with adequate street lighting.
- (iv) The width of the footpath at the stand should be sufficient for accommodating queuing passengers as well as for the circulation of pedestrians at the same time.
- (v) No stand should cause any obstruction to existing run-ins or fire hydrants.
- (vi) Whether it is necessary to cancel parking spaces or remove guardrails to facilitate the provision of the stand.

The procedures for designating public light bus stands are set up in Chapter 3.2.3 of the Departmental Instructions, Chapter 3. For information regarding the appropriate signs and markings for PLB stands, para 2.3.5.3 and 5.3.4.5 of Volume 3 of this Manual should be referred to.

3.5.3 There is no hard and fast rule on the size of PLB stand. The actual size depends on local environment and passenger demand. The desirable minimum size of a PLB stand should be large enough to accommodate 3 PLBs where site conditions permits.

3.5.4 The design of a PLB termini and stand should be able to cater for the use of existing PLB models which have 8.0 meters in length as far as possible.

3.5.5 Off-street PLB termini should be provided for GMBs in new developments where traffic demand warrants, or for RMBs from on-street relocation when opportunities arise. The designer of a PLB termini (both off-street and on-street terminus) should also provide night-time PLB parking therein as far as possible. The number of departure bays and passenger platforms will depend on either the number of red PLBs that may accumulate during peak periods or the number of green minibus routes planned for the development. Departure bays should be 3.0 metres wide between kerbs, and long enough to accommodate at least 3 PLBs. At least one double-width bay should be required to facilitate shared use and bypassing. Passenger shelters should be provided for all new purposely built green minibus termini. The desirable minimum width of the passenger platform should be 2.5 metres to

accommodate the shelter and queue railings. Where no passenger shelter is provided, the minimum width can be reduced to 2 metres.

- 3.5.6 For erection of passenger shelters at stands or existing termini and regulator's kiosks, Transport Department shall examine the proposals from the operational need and traffic management viewpoint, and consult the Advisory Committee for Aesthetics of Bridges and Structures (for new design only), the Regional Highway Engineer and other concerned departments in accordance with Departmental Instructions.

3.6 Stopping Places

- 3.6.1 Stopping places may be designated within prohibited/restricted zones for GMBs to pick up/set down passengers. All such stopping places must be specified in the schedule of service of the route issued under the passenger service licence. Permits are issued to green minibuses for operation or stopping within the prohibited/restricted zone in accordance with regulation 50 of Road Traffic (Registration and Licensing of Vehicles) Regulations.
- 3.6.2 Stopping places for green minibuses may be designated outside restricted zones at strategic locations at major transport interchanges, or other locations where circumstances require.
- 3.6.3 Since RMBs are unlikely to be allowed to pick up or set down passengers within restricted zones, the application of stopping place for RMBs is much more limited as compared with GMBs. However, consideration may be given to carefully selected locations outside restricted zones where circumstances require.
- 3.6.4 In determining the exact locations of stopping places, factors such as passenger convenience, road safety and other traffic management objectives must be considered.
- 3.6.5 For information regarding the appropriate signs and markings for stopping places, para. [2.3.5.2 and 5.3.4.2] of Volume 3 of this manual should be referred to.

3.7 Public Light Bus Prohibition and Stopping Restriction

- 3.7.1 PLB prohibitions are normally imposed under the following circumstances :
- (i) for traffic management reasons;
 - (ii) for protection of green minibuses services; and
 - (iii) in pursuance of the policy guidelines as set out in para. 3.3.2.
- 3.7.2 Prohibition on RMBs may be imposed in the immediate vicinity of the terminal points of green minibuses routes so as to protect the operations of green minibuses and to eliminate possible conflict between the two.
- 3.7.3 Stopping restriction for PLBs may be considered under the following situations :-
- (i) where PLB activities are found to be a significant factor affecting the free flow of traffic;
 - (ii) where it is necessary to exercise the policy of containment as set out in para. 3.3.1(iii).
 - (iii) where stopping activities of public light buses are identified as a contributory factor of traffic accidents.
- 3.7.4 Where stopping restrictions are introduced as part of the local traffic management scheme for improving road safety and traffic flow, alternative facilities for picking up or setting down passengers should be provided as far as possible, usually in side streets. The facilities provided may be in the form of a stand, or a stopping place, or just unspecified kerbside space as appropriate.
- 3.7.5 To ensure public light buses pick up/set down passengers within PLB stand only, consideration may be given to designating stopping restrictions for public light buses in the immediate vicinity of the PLB stand.
- 3.7.6 GMBs can normally operate on bus only lanes along the specified routeing through the issue of permits. This, however, is not applicable to RMBs.

TPDM Volume 9 Chapter 4 – Taxis

4.1 Reference

- 1 Motor Vehicles (First Registration Tax) Ordinance, Chapter 330
- 2 Road Traffic Ordinance, Chapter 374
- 3 Road Traffic (Construction and Maintenance of Vehicles) Regulations, Chapter 374A
- 4 Road Traffic (Public Service Vehicles) Regulations, Chapter 374D
- 5 Road Traffic (Registration and Licensing of Vehicles) Regulations, Chapter 374E
- 6 Road Traffic (Safety Equipment) Regulations, Chapter 374F
- 7 Road Traffic (Traffic Control) Regulations, Chapter 374G
- 8 Transport Planning and Design Manual Volume 3, Traffic Signs and Road Markings
- 9 Transport Planning and Design Manual Volume 6 Chapter 8, Facilities for People with Disabilities
- 10 Licensing Conditions for Taxi

4.2 Introduction

4.2.1 Definition

4.2.1.1 As defined under Motor Vehicles (First Registration Tax) Ordinance, Chapter 330, 'taxi' means any motor vehicle, constructed or adapted for use solely for the carriage of a driver and not more than five persons and their personal effects, which stands or plies for hire and in which the passengers are carried for hire or reward under a contract express or implied for the use of the vehicle as a whole at a rate indicated by the taximeter.

4.2.1.2 The Road Traffic Ordinance Chapter 374 defines taxi as 'a motor vehicle which is registered as a taxi under this Ordinance.' Taxi is specifically classified in Schedule 1 of the Road Traffic Ordinance for registration and licensing purpose.

4.2.2 Categories of Taxis

4.2.2.1 There are three categories of taxis in Hong Kong, namely, Urban taxis, New Territories (N.T.) taxis and Lantau taxis. The N.T. taxis and Lantau taxis were introduced in 1976 and 1983 respectively. The total registered number of the Urban, N.T. and Lantau taxis as at 30 April 2004 are 15,250, 2,838 and 50 respectively.

4.2.2.2 Each category of taxi is differentiated in appearance by specific colour scheme :-

- (i) Urban taxis - roof panel including all support pillars in silver and lower portion of the body work including bonnet and boot panels in red.
- (ii) N.T. taxis - roof panel including all support pillars in white and lower portion of the body work including bonnet and boot panel in green.
- (iii) Lantau taxis - roof panel including all support pillars in white and lower portion of the body working including bonnet and boot panels in light blue.

4.2.2.3 Regulation 47 of the Road Traffic (Construction and Maintenance of Vehicles) Regulations, Chapter 374A has made provision for the Commissioner for Transport, to specify the colour scheme for taxis by notice published in Gazette.

4.3 Administration and Control

4.3.1 Licensing of Taxis

4.3.1.1 Under Section 23 of the Road Traffic Ordinance, Chapter 374, the Chief Executive in Council by notice in the Gazette may limit the number of vehicles which may be registered as taxis. Taxi licences have been issued by public tender since 1964 to provide the registered holders a right to own and operate a taxi. Since 1994, it has been Government policy to issue new taxi licences as and when necessary, having regard to -

- (i) the demand for taxi services;
- (ii) the financial viability of the trade; and
- (iii) the likely impact of the increase in number of taxis on traffic conditions.

There is no pre-set quota on the number of taxi licences to be issued in a given period of time so as to avoid manipulation in the bidding and trading of taxi licences.

4.3.1.2 Part IV of the Road Traffic (Registration and Licensing of Vehicles) Regulations, Chapter 374E has made provisions to empower the Commissioner for Transport to license taxis. On licensing a taxi, the area within which the taxis can operate would be specified.

4.3.1.3 Regulation 26(1)(b) of the Road Traffic (Registration and Licensing of Vehicles) Regulations, Chapter 374E has made provisions for the Commissioner for Transport to license taxis by calling for tenders on the payment of a premium. Taxi licences have been issued by public tender at a premium since 1964. Bidders are required to pay a deposit of \$50,000 for each licence applied for. A successful tenderer has to settle payment of premium within 14 days and license the taxis within six months.

4.3.1.4 The Road Traffic Ordinance and its subsidiary legislations have made no provisions to limit the operating area of Urban taxis.

4.3.1.5 Regulation 29 of the Road Traffic (Registration and Licensing of Vehicles) Regulations, Chapter 374E stipulated that the operation of N.T. and Lantau taxi is subject to area limitations. The permitted area within which the N.T. and Lantau taxis can operate is specified in Schedule 7 of the Road Traffic (Registration and Licensing of Vehicles) Regulations, Chapter 374E.

4.3.1.6 Lantau taxis, licensed to operate on the island of Lantau and Chek Lap Kok only, are also issued with closed road permits under Regulation 49 of the Road Traffic (Registration and Licensing of Vehicles) Regulations, Chapter 374E to allow their operations on the closed roads in Lantau.

4.3.2 Vehicle Specifications

4.3.2.1 The construction and design requirements of a taxi are specified in the Road Traffic (Construction and Maintenance of Vehicles) Regulations, Chapter 374A. The maximum dimensions and weight of taxis as specified in Schedules 1 and 2 of the above Regulations are as follows:-

- overall length 6.3 metres
- overall width 2.3 metres
- overall height 2.0 metres
- maximum gross vehicle weight 3.0 tonnes

4.3.2.2 The overall height mentioned above includes the permissible height of the roof-top advertisement. The maximum height of the advertisement structure should not exceed 450 millimetres.

4.3.2.3 Apart from complying the general vehicle designs and maintenance requirements as stipulated in Part II of the Road Traffic (Construction and Maintenance of Vehicles) Regulations, Chapter 374A, taxis

should also be constructed and equipped in accordance with the specific provisions in Part III of the Regulations.

4.3.2.4 Schedule 3 of the Road Traffic (Construction and Maintenance of Vehicles) Regulations, Chapter 374A has specified that the maximum passenger seating capacity of taxi is five.

4.3.2.5 Every taxi registered on or after 1 January 2001 should be equipped with approved seat belts for the driver's seat and all passengers' seats in the front and rear in accordance with Road Traffic (Safety Equipment) Regulations, Chapter 374F.

4.3.2.6 The owner of a liquefied petroleum gas (LPG) taxi shall fix a plate, which contains the taxi's registration mark in Braille and in tactile form, inside taxi at its rear left-hand door. The specifications of such plate and the place at which it should be fixed are shown in Annex A of Licensing Conditions for Taxi.

4.3.3 Advertising on Taxi and inside Taxi Compartment

4.3.3.1 In accordance with Regulation 54(1)(b) of the Road Traffic (Construction and Maintenance of Vehicles) Regulations, Chapter 374A and Condition 11 of the Licensing Conditions for Taxi, taxis are permitted to display/broadcast advertisements upon approval of the Commissioner for Transport.

4.3.3.2 The areas for the display/broadcast of advertisements on taxis and inside taxi compartments are limited to :-

- (i) The front and /or rear door panels and fenders.
- (ii) Bulkheads, roof (side) panels and seat-backs in the vehicle compartment.
- (iii) Exterior roof of the vehicle.
- (iv) Boot panel of the vehicle.
- (v) Interior parts of the vehicle.
- (vi) The upper end of rear windscreen

4.3.3.3 (i) The advertisements on the door panels may be displayed below the windows, on either or both sides, provided that sufficient space remains on the sides of the vehicles for the painting of the 'TAXI' markings in compliance with Regulation 45(b) of the Road Traffic (Construction and Maintenance of Vehicles) Regulations, Chapter 374A.

(ii) The advertisements on the fenders may be displayed on either or both sides, provided that the logos for liquefied petroleum gas (LPG) taxi are conspicuous if the taxi is an LPG taxi.

(iii) For advertisements on the rear windscreen, the maximum height of the sign shall not exceed 127 millimetres measured from the uppermost transparent point of the rear windscreen excluding the black tinted surround and the width of the sign shall not exceed the width of the rear windscreen.

4.3.3.4 (i) For advertisements on roof, the structure carrying the advertisements (except Light Emitting Diode (LED) panel) shall not exceed 1250 millimetres in length nor exceed 450 millimetres above the roof at any point and the overall height of sign should not exceed 350 millimetres. It shall be designed and constructed to prevent leakage of any illumination other than through the advertisements or statutory TAXI signs. The structure shall be mounted along the longitudinal centerline of the roof and must incorporate the statutory 'TAXI' signs required to comply with Regulation 45(a) of the Road Traffic (Construction and Maintenance of Vehicles) Regulations, Chapter 374A.

- (ii) If advertisements are displayed on Light Emitting Diode (LED) panel, the following conditions should be complied:
- (a) The display panel should not exceed 1,250 millimetres in length and the overall height of the panel should not exceed 350 millimetres. The panel should not exceed 450 millimetres above the roof at any point;
 - (b) The light emitted from the display panel shall be diffused and should not cause distraction to other road users;
 - (c) The illumination, color and shape of the display shall not be such that they would be confused with traffic signs, traffic signals and all traffic management facilities. The display shall be in single color and the color shall not be blue, red, white or green;
 - (d) The display shall not contain flashing animation and shall not be in rolling or moving motion. Only simple symbols, graphics and characters are allowed;
 - (e) The period of each advertisement display shall last for more than 15 seconds;
 - (f) The time to change from one display to a new display shall not be more than 3 seconds. The change of display shall not jolt the other road user;
 - (g) The display shall not be switched on roads with speed limit exceeding 70 kilometres/hour; and
 - (h) The electric wiring system pertaining to the display panel shall be secured and protected.

4.3.3.5 For advertisements on boot panel, the structure carrying the advertisements shall be mounted on the rear of the taxi boot panel and shall not bear any sharp corners, edges or contours and affect the opening and closing of the boot lid. The maximum height of the uppermost part of the sign board shall not project more than 25 millimetres above the lowest transparent point of the rear window excluding the black tinted surround and the width of the structure shall not exceed the width of the boot panel. The structure shall be painted the same colour as the taxi boot panel. The advertisements shall be displayed on the rear vertical surface only and shall not use reflective material or have any kind of illumination. The advertisements and structure shall be maintained at all times in a sound and safe condition.

4.3.3.6 For advertisements displayed on Light Emitting Diode (LED) panel inside compartment, the display panel should not exceed 400 millimetres in length and both the overall height and the overall width of the panel should not exceed 70 millimetres. The light emitted from the display panel shall be diffused and should not cause distraction to other road users.

4.3.3.7 Video broadcasting system/TV/Liquid crystal display (LCD) for advertisements should be equipped only inside compartment and in compliance with the guidelines and conditions for advertisements in or on taxis.

4.3.3.8 Guidelines and conditions for advertisements in or on taxis are laid down in the letter of 'Approval for Display/Broadcasting of Advertisements on Taxi and inside Taxi Compartment', a copy of which is shown in the Appendix.

4.3.4 Revision of Permitted Area

4.3.4.1 Schedule 7 of the Road Traffic (Registration and Licensing of Vehicles) Regulations, Chapter 374E specifies the permitted areas in which the N.T. and Lantau taxis can operate. Amendments to Schedule

7 is required for any changes to the 'permitted areas'.

4.3.4.2 The permitted area of operations of N.T. taxis is kept under review and, where appropriate, adjusted in the light of changing circumstance such as the opening of new roads, major changes in land use and changes of transport needs. In examining any boundary revision, the following factors should be taken into account :-

- (i) The implications on the level of public transport service in rural areas as the result of the revision.
- (ii) The traffic management problems arising from the influx of N.T. taxis to the more lucrative built-up urban areas.
- (iii) The role of N.T. taxis in serving the rural population.
- (iv) Possible resurgence of illegal pak pai activities and request for Excess Passengers Permit service in rural area.
- (v) Control and enforcement difficulties.
- (vi) Implications of Urban and Lantau taxi service.

4.3.4.3 The affected District Councils and taxi operators (i.e. the Urban, N.T. and Lantau taxi associations) should be consulted about the proposal of 'permitted area' revision. The proposal will then be submitted to the Transport Advisory Committee and the Executive Council for policy approval. A LegCo resolution on the amendments to Schedule 7 of the Road Traffic (Registration and Licensing of Vehicles) Regulations, Chapter 374E is required to effect the change.

4.3.4.4 To indicate the end of the permitted areas for N.T. taxi operation, traffic signs of the type shown in Figure No. 1 in Schedule 11 of the Road Traffic (Registration and Licensing Vehicles) Regulations, Chapter 374E should be erected on roads leading from inside the permitted area for N.T. taxis to any place outside that permitted area.

4.3.5 Stopping Restrictions for specified vehicles (including taxis)

4.3.5.1 Readers of this section should make cross reference to Volume 3 Chapter 2 Section 2.3.2.

4.3.5.2 The delineation of the no stopping zone is made by traffic sign and road markings as set out in para. 2.3.2.89 - 91 in Volume 3.

4.3.5.3 Before designation of no stopping restriction, the Police, relevant District Offices and the taxi trades should be consulted.

4.3.6 Guidelines for Relaxation of Restricted Zones on Sundays and Public Holidays (for taxis and all vehicles)

4.3.6.1 As traffic is generally lighter on most roads on Sundays and Public Holidays, the general principle is to relax peak hour only (i.e. 8am-10am / 5pm-7pm) and (7am-7pm) restrictions on Sundays and Public Holidays for all vehicles.

4.3.6.2 In exceptional areas where traffic is still busy or even busier on Sundays and Public Holidays, relaxation of restricted zones should continue to be examined on a street by street basis. As far as practicable, restrictions should be relaxed to give maximum benefits and convenience to motorists and passengers unless such relaxation will cause safety hazard or serious adverse impacts on traffic.

4.3.6.3 As 24-hour and 7am-12midnight restrictions are usually imposed for safety reasons and in business areas where traffic volume is high at all times, relaxation will continue to be examined on a site by site basis.

For blanket relaxation of peak hour and 7am-7pm restrictions, implementation programme is as follows:

- Review existing restrictions: 3 months
- Consultation: 3 months
- Implementation: 6 months
- Total: 12 months

The above programme is for implementation over the whole territory. Implementation for individual districts may be staggered within this time frame. Consultation with taxi operators is mainly through regular conferences held between Transport Department and representatives of major taxi associations.

4.3.7 Guidelines for Designation of No Stopping Restrictions (Except Taxis), Taxi Pick-up and Drop-off Points and Taxi Drop-off Points

4.3.7.1 No Stopping Restrictions (Except Taxis)

- (i) This is introduced before Schedule 1 of the Road Traffic (Traffic Control) Regulations, Chapter 374G was amended to allow the designation of taxi pick-up and drop-off points. The exception allows taxis to pick up and set down passengers within a restricted zone during its hours of restriction.
- (ii) Where traffic conditions permit, relaxation of no stopping restriction should apply to all vehicles as far as possible. The implementation of no stopping restriction (except taxis) should be examined on a case by case basis. For traffic reasons, and easy understanding of taxi drivers and passengers, no stopping restriction (except taxis) should be implemented as a taxi pick-up and drop-off point using Figure 430 of Schedule 1 of the Road Traffic (Traffic Control) Regulations, Chapter 374G. Such an arrangement will replace the existing practice of no stopping restriction (except taxis), of which will be discontinued upon successful trial and implementation of the taxi pick-up and drop-off points.
- (iii) Where demand for boarding or alighting from taxi is high and where taxi stand cannot be established in the vicinity, the alternative of providing taxi pick-up or drop-off points and taxi drop-off points should be considered.
- (i) For the proposed locations of taxi pick-up and drop-off point, prior consultation with the Police and the taxi trades is required.

4.3.7.2 Taxi Pick-up and Drop-off Points

- (i) Taxi pick-up and drop-off point is intended to facilitate taxi to provide point-to-point service by allowing them to pick up and set down passengers in busy areas while minimizing adverse traffic impact. Waiting of taxis at the taxi pick-up and drop-off point is not allowed. The use of taxi pick-up and drop-off point should be considered on its own merits taking into account traffic conditions and actual experience. If the arrangement is causing adverse traffic impact due to abuse by the taxi trade, the taxi pick-up and drop-off point should be withdrawn.
- (ii) Only taxis are allowed to use the taxi pick-up and drop-off facility because of its role to provide a point-to-point service to the public. The facility is not available to other vehicles including private cars.
- (iii) The following should be taken into consideration when formulating taxi pick-up and drop-off points:
 - (a) the carriageway should have at least 2 lanes or at least 10.3 metres wide for two way single carriageway to allow other vehicles to overtake the stationary taxi;

- (b) the traffic condition during the restriction period should not be adversely affected as a result of the designation of the taxi pick-up and drop-off point;
- (c) there is no similar facility available within walking distance of 300 metres;
- (d) the taxi pick-up and drop-off point should have good sightline and should be located close to major pedestrian activities, e.g. pedestrian entrance to housing estates, shopping centres, GIC facilities, etc.;
- (e) the taxi pick-up and drop-off point should be provided at periphery of pedestrians priority/traffic calming areas.
- (f) the taxi pick-up and drop-off point should desirably be accommodated in a layby wherever possible to minimize traffic disruption;
- (g) taxi pick-up and drop-off point can be designated at the periphery of congested commercial/shopping areas so that taxis can avoid entering such areas to set down passengers;
- (h) no taxi pick-up and drop-off point should be designated at location within 30 metres from road junction or pedestrian crossing;
- (i) taxi pick-up and drop-off point should not normally be designated immediately next to a bus stop. However, consideration may be given to the designation of taxi pick-up and drop-off point not less than 10 metres in front of a bus stop if there is no safety implication;
- (j) no taxi pick-up and drop-off point should be provided on road with speed limit above 50 kilometres/hour; and
- (k) to contain traffic disruption within tolerable limits, the length of road section at which taxi pick-up and drop-off point is to be designated should generally not exceed 10 metres.

4.3.7.3 Taxi Drop-off Points

- (i) Taxi drop-off point is intended to facilitate taxi setting down passengers only within restricted zones in busy areas while minimizing adverse traffic impact. Picking up of passengers is not allowed. The use of taxi drop-off point should be considered on its own merits taking into account traffic conditions and actual experience. If the arrangement is causing adverse traffic impact due to abuse by the taxi trade, the taxi drop-off point should be withdrawn.
- (ii) Only taxis are allowed to use the taxi drop-off facility because of its role to provide a point-to-point service to the public. The drop-off facility is not available to other vehicles including private cars.
- (iii) The following should be taken into consideration when formulating taxi drop-off points:
 - (a) the carriageway should have at least 2 lanes or at least 10.3 metres wide for two way single carriageway to allow other vehicles to overtake the stationary taxi;
 - (b) the traffic condition during the restriction period should not be adversely affected as a result of the designation of the taxi drop-off point;
 - (c) there is no similar facility available within walking distance of 300 metres;
 - (d) the taxi drop-off point should have good sightline and should be located close to

major pedestrian activities, e.g. pedestrian entrance to housing estates, shopping centres, GIC facilities, etc.;

- (e) the taxi drop-off point should desirably be accommodated in a layby wherever possible to minimize traffic disruption;
- (f) taxi drop-off point can be provided at the front end of a taxi stand to facilitate setting down passengers without the vehicle having to join the taxi queue;
- (g) taxi drop-off point can be designated at the periphery of congested commercial/shopping areas so that taxis can avoid entering such areas to set down passengers;
- (h) no taxi drop-off point should be designated at location within 30 metres from road junction or pedestrian crossing;
- (i) taxi drop-off point should not normally be designated immediately next to a bus stop. However, consideration may be given to the designation of taxi drop-off point not less than 10 metres in front of a bus stop if there is no safety implication;
- (j) no taxi drop-off point should be provided on road with speed limit above 50 kilometres/hour; and
- (k) to contain traffic disruption within tolerable limits, the length of road section at which taxi drop-off point is to be designated should generally not exceed 10 metres.

4.3.8 Guidelines for Provision of Laybys within Restricted Zones for Picking Up and Setting Down of Passengers

4.3.8.1 General

- (i) Where existing pedestrian footway is 5 metres wide or more and the pedestrian flow thereof is anticipated to be low, consideration should be given to provide general laybys within restricted zones for picking up/setting down passengers. Particular attention should be given to locations where there are no side streets available for kerbside activities and the restricted zone continues for a distance of 500 metres or more along the main street. Local narrowing of the carriageway to form a layby may be considered where road capacity is not critical.
- (ii) On roads with speed limit of 70 kilometres/hour or above, provision of laybys would not be appropriate as vehicles pulling into and out of a layby would create a safety hazard to passing traffic. Nevertheless, where there are service roads parallel to a trunk road or primary distributor, provision of laybys on the service roads can be considered.

4.3.8.2 On-street Laybys

For existing streets which cannot satisfy the requirement mentioned above, opportunities should be taken to provide laybys under:

- (i) Road widening schemes
Where there is a high demand for picking up/setting down activities, consideration should be given to provision of laybys under a road widening scheme, provided that the existing traffic volume has not exceeded the link capacity. Otherwise, provision of additional traffic lanes will be more appropriate.
- (ii) Pedestrian schemes
In general, facilities for loading and unloading are provided at the periphery of pedestrian priority areas. At part-time pedestrian streets, laybys are provided for loading and

unloading. Facilities for loading and unloading are also provided at traffic calming streets. One-lane traffic calming street should consist of a driveway with adjoining laybys, a clear cross width of 6 metres should be maintained along the street.

4.3.8.3 Off-street Laybys

- (i) There are standard requirements for the provision of laybys for taxis and private cars for different types of developments given in the HK Planning Standards and Guidelines (HKPSG), and these standards should be strictly adhered to unless there are insurmountable site constraints. Free access to such laybys for taxis during day time if not 24 hours need to be secured through conditions in the lease and when designating Restricted Roads within public housing estates.
- (ii) Even where there are no specific requirements under the HKPSG for laybys for certain new developments, consideration should be given at the planning stage to provide laybys within the lot and to secure free access for taxis through the lease conditions.

4.3.8.4 Signs and Markings

For laybys with a high demand by taxis and other vehicles, warning traffic signs ‘Waiting vehicle will be prosecuted’ together with yellow hatched markings should be provided to deter vehicles standing within the layby.

4.3.9 Guidelines for Provision of Spaces for Short Term Taxi Parking

4.3.9.1 As a general measure, short term metered parking spaces should be provided near public toilets, as far as practicable, to facilitate taxi drivers and other motorists.

4.3.9.2 Consideration should be given to provide laybys, as far as practicable, near new public toilets when commenting on town plans.

4.3.9.3 As registered taxi owners are required to provide designated parking spaces for their taxis, there is no requirement to provide parking space for overnight taxi parking.

4.3.9.4 To facilitate shift changing, meal break and rest, arrangements will be made to allow taxis to use the rear portion of taxi stands at selected locations for temporary parking during non peak hours, say from 10:00 am to 12 noon for day shift drivers, and from 3:00 pm to 6:00 pm for night shift drivers. Taxi drivers must switch off the engines when they park their taxis temporarily at the taxi stand.

4.3.9.5 In the site search process for provision of space at the rear portion of taxi stands for temporary taxi parking, consideration is given to:

- (i) The taxi stand should have adequate space (or long enough) to accommodate both temporary taxi parking and active taxi operations at the same time;
- (ii) Temporary taxi parking at the taxi stand will not create obstruction to normal taxi operations and other traffic;
- (iii) Temporary taxi parking at the taxi stand will not cause noise and other environmental nuisance to the nearby shop tenants and residents; and
- (iv) Adequate traffic signs and road markings should be provided to delineate the exact location(s) or space(s) for temporary taxi parking at the taxi stand.

4.3.10 Consultation with Taxi Operators

4.3.10.1 Consultation with taxi operators is mainly through regular conferences between Transport Department and representatives of major taxi associations. For each type of taxis, three conferences will be held

annually.

4.3.10.2 To deal with operators of different types of taxis, three separate conferences are held : -

- (i) Conference on Urban Taxi Operations – chaired by Assistant Commissioner for Transport (Management and Paratransit) or Chief Transport Officer (Taxi Planning)
- (ii) Conference on N. T. Taxi Operations – chaired by Assistant Commissioner for Transport (Management and Paratransit) or Chief Transport Officer (Taxi Planning)
- (iii) Conference on Lantau Taxi Operations – chaired by Assistant Commissioner for Transport (Management and Paratransit) or Chief Transport Officer (Taxi Planning)

4.3.10.3 Applications to be a new member of these conferences will be dealt by Transport Department. To be eligible as a member of the conferences, the taxi association should meet the following requirements :-

- (i) The associations should be registered by either the Company Registrar or the Registrar of Societies. The association has to provide proof of its bona fide and to submit its memorandum and articles of association for checking.
- (ii) The general objectives of the association are to promote interest of the trade and better service to the public.
- (iii) The membership of the association (except for Conference on Lantau Taxi Operations) is generally not less than 200. For new applicants for membership of the Conferences with effect from 2002, the minimum membership requirement or number of taxis owned are as follows:

Conference on Lantau Taxi Operations	30 Lantau Taxi Drivers/Owners
Conference on N.T. Taxi Operations	200 N.T. Taxi Drivers/Owners
Conference on Urban Taxi Operations	200 Urban Taxi Drivers/Owners

- (iv) The membership of the existing associations in the above conferences could be retained if the total membership of these associations is not less than 95% of the level when they first joined these conferences, or the above-mentioned minimum membership requirement (whichever is the lower).

4.4 Taxi Stands

4.4.1 Roadside Taxi Stands

4.4.1.1 Regulation 30 of Road Traffic (Public Service Vehicles) Regulations, Chapter 374D has made provision for the Commissioner for Transport to designate taxi stands on road (i.e. an area within which a taxi may stand or ply for hire). Traffic aids for designation of taxi stands are set out in Figure Nos. 4, 7, 9, 10, 10A, 11 and 12 of Schedule 4 of the Road Traffic (Public Service Vehicles) Regulations, Chapter 374D.

4.4.1.2 In areas where there is high demand for taxis, the designation of taxi stand will help passengers and taxis to formulate queues leading to order of kerbside activities.

4.4.1.3 The general criteria for designation of taxi stands are as follows :-

- (i) The stand should be sited at location of popular demand for the convenience of passengers. As such, taxi stands should be provided at major commercial/business/industrial areas and major transport interchange where passenger interchanging activities are envisaged (e.g. railway station, ferry pier etc.) The stand should also be sited at perimeters of pedestrian priority areas/streets and traffic calming areas. Provision of separate taxi stands for cross harbour taxis should be considered at districts adjacent to the cross harbour tunnels at both sides of the harbour.
- (ii) If site condition permits, the stand should be designed in such a way that the head of taxis are facing pedestrian desire path. This is to avoid situation whereby taxis are stacked at the tail of the stand causing disruption to the queuing order. If such a design is not feasible because of site constraint, the stand can be designed along the passenger queue as an alternative.
- (iii) Consideration should be given to the traffic routeings in the area to facilitate the departing taxis to take a more direct route to the desired destination and avoid taxis being trapped by traffic in the area.
- (iv) Taxi stands should normally be accommodated in the Street Furniture and Greening Zone of the footpath. The footway adjacent to taxi stand should be wide enough to ensure adequate queuing space for potential taxi passengers as well as other pedestrian movements. For taxi stands without passenger shelters or queue rails, a minimum footway clear width of 3m as stipulated in Volume 6 Chapter 10 should be encouraged. If taxi shelters or queue rails are provided, additional width should be allowed in the Zone and a wider footway should be provided to allow other pedestrians to pass.
- (v) The stand should not be located in such a way as to obstruct traffic movement. On-street taxi stand should be accommodated in layby as far as possible.
- (vi) It should not be located as to cause road safety concern. Minimum vehicle/vehicle and pedestrian/vehicle conflicts should be ensured.
- (vii) The stand should not be located as to reduce the recommended visibility distance.
- (viii) Where different categories of taxis operate, separate stands for each type of taxi is recommended where site condition permits. Supplementary plates should be added to differentiate the use of the stands. Figure No. 10 and 11 of the Fourth Schedule to the Road Traffic (Public Service Vehicles) Regulations are used for N.T. Taxi stand.

4.4.1.4 Taxi stands or laybys should also be provided at major housing estates/private residential developments where demand for taxis is high (in particular those estates/residential developments which are surrounded by main roads with 24-hour no stopping restriction imposed). For small developments

where provision of taxi stands or laybys inside the estate is difficult, consideration may be given to allow some exceptions. For new major developments, provision of taxi stands, and loading and unloading facilities for other public transport modes should be stipulated in the planning brief if there is one, or it should be carefully examined when the Traffic Impact Assessment is being undertaken. In case there is no transport interchanges provided within the housing estate, a layby for taxi is usually required. The design of a taxi layby is shown in Diagram 4.4.1.1.

- 4.4.1.5 The requirements for provision of taxi stands or laybys for loading and unloading should be indicated to the Housing Department to ensure provision of access, taxi stand or loading and unloading facilities for taxis within housing estates before approving designation of housing restricted roads.
- 4.4.1.6 For preparation of pedestrian schemes, taxi stands should be considered at locations on peripheral roads near the proposed pedestrianised areas to ensure the pedestrianised area can still be conveniently served by taxis.
- 4.4.1.7 Taxi stands may be used for parking provided that a supplementary plate as shown in Figure No.9 of Schedule 4 of the Road Traffic (Public Service Vehicles) Regulations, Chapter 374D, is added to the 'Taxi stand' sign. Before designation of a taxi stand for parking purpose, the Police, District Office and the taxi trades should be consulted.
- 4.4.1.8 There is no hard and fast rule on the size of a taxi stand. The actual size depends on local environment and passenger demand. Nonetheless, it is recommended that a taxi stand should at least be long enough to accommodate at least 5 taxis (and at least 10 taxis for cross harbour taxi stand. The overall maximum length of a taxi as specified in the Road Traffic (Construction and Maintenance of Vehicles) Regulations, Chapter 374A is 6.3 metres.
- 4.4.1.9 Some of the commercial/business districts may not allow the establishment of long taxi stands but for planning purpose stands with spaces ranging from 5-10 taxis should be considered. In industrial areas where demand for taxis is high but provision of taxi stand is not feasible, consideration should be given to provide taxi pick-up and drop-off points to facilitate taxi operation.
- 4.4.1.10 For on-street taxi stands which have over five to ten spaces, a space in front of the stand should be designated as a taxi drop-off point to facilitate taxi driver who does not want to wait in the taxi queue to set down his passengers.

DIAGRAM 4.4.1.1 : STANDARD TAXI LAYBY SETTING OUT DETAILS

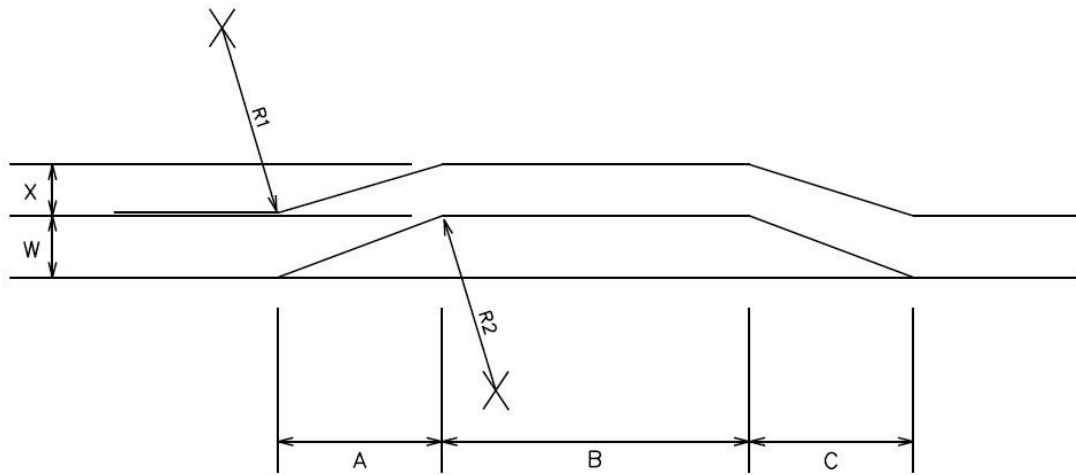

	R1 (m)	R2 (m)	A (m)	B (m)	C (m)	W (m)	X (m)
STANDARD SETTING OUT DETAILS	8.0	5.0	8.0	15.0	8.0	3.0	2.5
MINIMUM SETTING OUT DETAILS	6.0	5.0	6.0	15.0	6.0	2.7	2.0

4.4.2 Taxi Stands at Transport Interchange

- 4.4.2.1 Taxi stands should be provided at major transport interchange such as ferry concourses, railway stations, etc. to form part of the interchange facilities.
- 4.4.2.2 To cater for the influx of passengers alighting from such mass carriers as ferries, train etc., taxi stands at transport interchanges are usually of larger size than normal on-street stands. It is suggested that the minimum size of such taxi stands should be capable of accommodating 6 taxi spaces.
- 4.4.2.3 The maximum width of a taxi is 2.3 metres. A single-width departure bay should be 3.0 metres wide between kerbs. A double-width bay should be provided, if feasible, to allow taxis which do not want to join the queue to by-pass. It is recommended that the minimum width of the passenger platform should be 2.5 metres if passenger shelter is to be erected. Where no passenger shelter is provided, the minimum width may be reduced to 2 metres.
- 4.4.2.4 For taxi stand at major transport interchange, a passenger alighting area near the taxi stand should be provided, if site condition permits. This arrangement facilitates taxis to alight passengers before proceed to the stand and to alleviate the taxi stacking problems as the empty taxis may choose to wait at the taxi stand or leave the terminus for hire elsewhere.
- 4.4.2.5 At transport interchanges where different types of taxis will operate, separate stands for each type of taxi is recommended. Supplementary plates should be added to differentiate the use of the stands. Figure Nos.10, 10A and 11 of Schedule 4 of the Road Traffic (Public Service Vehicles) Regulations, Chapter 374D are used for N.T., Lantau and Urban taxi stand respectively.
- 4.4.2.6 At such transport interchanges as international ferry pier, railway stations and airport, special consideration should be so located that they are as close to the departure/arrival halls as possible. In particular, passengers should not be required to cross a large number of bus or PLB bays in order to get to/from the taxi stand.
- 4.4.2.7 Taxi drop-off points should be provided at the front end of a taxi stand in a double-width bay to

facilitate setting down passengers without the vehicle having to join the taxi queue.

4.4.3 Queue Rails and Shelters

4.4.3.1 Queue rails are normally provided at taxi stands at transport interchanges and those at busy locations.

4.4.3.2 There is at present no standard design for queue rails. However, for those taxi stands at major transport interchanges where high turnover of taxis is expected, special consideration should be given to the design of queue rails and the taxi stand layout, allowing more than one taxi to board/alight passengers at the same time (e.g. with more gaps at the front of the railing etc.) Highways Department should be consulted before erection.

4.4.3.3 There is at present no standard design for taxi shelter and no single authority is responsible for the provision. Only design proposals for taxi shelter that have been accepted by ACABAS should be adopted. Sheltering of taxi stand, either in the forms of covered walkway or individual shelter, is currently provided at major transport interchanges (i.e. ferry piers and railway station), and funded by the project. There are also shelters provided out of District Council. At present, the provision of taxi shelters is mainly constructed by Highways Department under the Government funding in most of the occasions.

4.4.3.4 Passenger shelters should be provided at taxi stands where site condition permits. If taxi shelter in a new development or transport related project is considered necessary, opportunity should be taken to provide and finance the facilities by the project.

4.4.3.5 Readers of this section should make cross reference to Chapter 8 Section 8.8 “Public Transport Services for People with Disabilities” in Volume 6 of Transport Planning and Design Manual.

	R1 (m)	R2 (m)	A (m)	B (m)	C (m)	W (m)	X (m)
STANDARD SETTING OUT DETAILS	8.0	5.0	8.0	15.0	8.0	3.0	2.5
MINIMUM SETTING OUT DETAILS	6.0	5.0	6.0	15.0	6.0	2.7.0	2.0

TPDM Volume 9 Chapter 6 – Non-Franchised Buses

6.1 References

- 1 *Public Bus Services Ordinance, Cap.230, HKSAR*
- 2 *Road Traffic Ordinance, Cap. 374, HKSAR*
- 3 *Road Traffic (Public Service Vehicles) Regulations, Cap. 374D, HKSAR*
- 4 *Road Traffic (Parking) Regulations, Cap. 374C, HKSAR*
- 5 *Road Traffic (Construction and Maintenance of Vehicles) Regulations, Cap. 374A, HKSAR*
- 6 *Fixed Penalty (Traffic Contravention) Regulations, Cap.237A, HKSAR*
- 7 Transport Department *Transport Planning and Design Manual, Volume 2, HKSAR*
- 8 Transport Department *Transport Planning and Design Manual, Volume 7, Chapter 6, HKSAR*
- 9 Transport Department *Transport Planning and Design Manual, Volume 9, Chapter 2, HKSAR*
- 10 Planning Department *Hong Kong Planning Standards and Guidelines, HKSAR*

6.2 Introduction

6.2.1 Definition

6.2.1.1 Non-franchised bus service is a collective term for bus service which is operated by operator(s) without a franchise granted under the Public Bus Services Ordinance (Cap. 230). The operation of non-franchised bus service requires a Passenger Service Licence (PSL) issued by Commissioner for Transport (Commissioner) under Section 27 of the Road Traffic Ordinance (Cap. 374).

6.2.2 Legislation

- 6.2.2.1 (i) Non-franchised bus service may be operated by either private or public buses. Section 2 of Cap. 374 defines “private bus” as a bus used or intended for use :
- (a) otherwise than for hire or reward; or
 - (b) for the carriage of passengers who are exclusively –
 - the students, teachers and employees of an educational institution; or
 - disabled persons and persons assisting them, whether or not for hire or reward.
- (ii) Under the same section of Cap. 374, a “public bus” is defined as a bus, other than any private bus, which is used or intended for use for hire or reward.
- 6.2.2.2 (i) Section 27(5) of Cap. 374 defines a private bus service which is authorized to operate by a PSL issued by the Commissioner under Section 27 of the same Ordinance as :
- (a) a student service, that is to say, a service for the carriage to or from an educational institution of students thereof and persons accompanying or in charge of such students or who teach at the educational institution, in private buses registered in the name of the educational institution;
 - (b) an employees’ service, that is to say, a service provided by an employer for the carriage of his employees to or from their place of work, in private buses registered in the name of the employer;
 - (c) a disabled persons’ service, that is to say, a service provided exclusively for the carriage of disabled persons and of persons employed to assist them; and
 - (d) any other service, which is not for hire or reward, approved by the Commissioner.
- (ii) Section 27(4) of Cap.374 further defines a public bus service which is authorized by a PSL issued by the Commissioner under Section 27 of the same Ordinance as a service which :
- (a) is for the carriage of passengers by public bus; and
 - (b) is of a type specified in Section 4(3) of Cap. 230 or of any other type approved by the Commissioner; and
 - (c) is not required to be operated under a franchise granted under the Cap. 230.
- (iii) Under Section 4(3) of Cap. 230, the types of non-franchised public bus service, which are authorized to operate by a PSL issued by the Commissioner under Section 27 of Cap. 374,

include:

- (a) tour service
- (b) international passenger service
- (c) hotel service
- (d) student service
- (e) employees' service
- (f) residents' service
- (g) multiple transport service

6.2.2.3 In addition to the services listed in paragraph 6.2.2.2, the registered owner of a public bus, if permitted under the terms of a PSL which is in force in respect of the vehicle, may hire the vehicle to any person under Regulation 38 of the Road Traffic (Public Service Vehicles) Regulations.

6.2.3 Policy

6.2.3.1 Non-franchised buses play a supplementary role in the public transport system. Permitting non-franchised bus operators to provide services to schools and work places helps reduce the peak-hour passenger demand on franchised bus service, and hence enables franchised bus operators to keep down the level of resources left idle during the off-peak period. This will help stabilize the fare level of franchised bus service. However, the operation of the non-franchised buses should not compete directly with franchised buses and green minibuses to avoid wasteful duplication of resources.

6.2.3.2 Apart from being less efficient than franchised buses, non-franchised buses may cause congestion in areas that are common origins/destinations. A balance should therefore be maintained between effective use of public transport facilities and freedom of choice for the public. Application of the inter-modal co-ordination policy needs to be based on factors such as changes in demand pattern, convenience and expectation of the travelling public, capacity of competing modes, road traffic condition and availability of kerbside and terminal facilities. While non-franchised buses will continue to play a supplementary role especially during the peak, the problem of congestion caused by these activities should be addressed and measures to alleviate the congestion problem should be introduced where appropriate.

6.2.4 Application

6.2.4.1 Hotel service (A02), Student service (A03)¹, Employees' service (A04), International passenger service (A05)², Residents' service (A06), Multiple transport service (A07) and Contract Hire Service (A08)³ require schedules of service to be submitted by the operator(s) showing the terminal points, routings, stopping places, timetables, fares and vehicle allocation to the Transport Department for approval.

6.2.4.2 Applications to run a residents' service must be made by the registered owners of the public buses to be deployed for the service. The application of a residents' service must be supported by the prospective user groups of the service. The user groups may include the management office, owners' incorporation and owners' committee.

6.2.4.3 Operation of employees' service are subject to compliance with the "Details of the Approved Employees' Service" issued by the Transport Department. Operation of employees' service for each employer and workplace must be pre-approved. No cash payment is allowed (coupon is acceptable).

¹ For post-secondary education institution only

² For non-cross boundary service only

³ With the same origin and destination areas operated for more than 15 days in a year

Unless otherwise permitted, only the employees of one employer shall be served at any one time.

6.2.4.4 The operation of any service, either solely or with other Passenger Service Licence holder(s), whether jointly or otherwise, by any bus specified in this licence or under the control of the same licensee, other than any type of public bus services specified in Section 4(3) of Cap. 230, with the same origin and destination areas, for more than 2 days either intermittently or consecutively in a period of 30 days, shall be subject to the prior approval of the Commissioner in writing.

6.2.4.5 Applications to operate non-franchised bus services should be made in prescribed application form with supporting documents for the relevant PSL.

6.2.5 Vehicle Types

6.2.5.1 Except for international passenger service, where approval for vehicles with left-hand steering has been given, all vehicles for non-franchised bus operation must have right-hand steering and left-hand side loading and unloading.

6.2.5.2 The dimensions of a non-franchised bus shall not exceed the overall dimensions specified in the First Schedule of the Road Traffic (Construction and Maintenance of Vehicles) Regulations (Cap. 374A) as follows:

Overall Dimensions of a Bus			
	Overall length	Overall width	Overall height
Single-decked	12.0 metres	2.5 metres	4.0 metres
Double-decked	12.0 metres	2.5 metres	4.6 metres
Articulated	15.0 metres	2.5 metres	3.5 metres

6.2.5.3 In accordance with Regulation 6(2) of Cap. 374A, the Commissioner may by permit in writing, subject to such terms and conditions as may be specified in the permit, authorize the use of a vehicle exceeding the above-specified dimensions.

6.2.5.4 Whilst the carrying capacity of a non-franchised bus varies according to vehicle type and specification, a bus should be constructed or adapted for the carriage of a driver and more than 19 passengers and their personal effects as defined within the meaning of Section 2 of Cap. 374.

- 6.2.5.5 Applications for the carriage of standees on non-franchised buses will be examined by the Transport Department, taking into account the number of standees permissible on each bus, which is subject to requirements under the Road Traffic (Construction and Maintenance of Vehicles) Regulations (Cap. 374A). In such a bus, grab-rails, straps, stanchions or other devices of adequate strength should be so placed that at least one such means of support is available to each standing passenger of normal height, and the floor is fitted with non-slip tread.
- 6.2.5.6 All non-franchised buses are required to undergo the vehicle examinations for the Certificate of Fitness (“COF”) when they reach, depending on whether standees are permitted, construction material of body and service type, 6, 10 or 12 years from year of manufacture, and thereafter at 3 or 4-year intervals.
- 6.2.5.7 The COF examinations mentioned in 6.2.5.6 will be in lieu of, and not additional to, the normal annual inspection for the Certificate of Roadworthiness in those particular years.
- 6.2.5.8 In-between annual inspections, non-franchised buses are also subject to call-up inspections by way of Vehicle Inspection Orders to monitor their safety and maintenance conditions. Usually vehicles with more defects found during annual or other inspections will be called-up more frequently.
- 6.2.5.9 Buses to be licensed to carry standees must be equipped with grab-rails, straps, stanchions etc. in compliance with the Road Traffic (Construction and Maintenance of Vehicles) Regulations (Cap. 374A) at the time of application. The equipment will be examined when the buses are due for the vehicle examinations.

6.3 Planning Guidelines

6.3.1 Bus priority measures

For passenger carriers, buses are the most efficient transport mode running on the road as they carry the largest number of people per unit of road space. Transport Department maintains a general principle to open up bus lanes to non-franchised buses where lane capacity allows. In fact, with appropriate indication on the supplementary plate used in conjunction with the Bus Lane sign, bus lanes can be opened to non-franchised buses except the following situations :

- (i) bus lanes which are heavily used by franchised buses and which have inadequate capacity or length to handle additional non-franchised bus;
- (ii) bus lanes which lead to franchised bus termini; and
- (iii) bus priority junctions to facilitate turning of franchised buses.

6.3.2 Planning of operation details

6.3.2.1 The operation details of non-franchised bus services are drawn up by the operators. As a part of the conditions for operating the bus services, the routing, frequency, stops and fares etc. may need to be approved by Transport Department, in particular for the scheduled services which include international passenger, residents' and multiple transport services.

6.3.2.2 Compared with franchised buses, non-franchised buses are subject to less administrative restrictions over the routing, frequency and fare chargeable.

6.3.3 Terminal Facilities

6.3.3.1 General

- (i) Non-franchised bus services are mostly terminated on-street. Off-street terminal points particularly in urban areas should be identified if possible to relieve the on-street traffic problem. This may be in the form of one or two additional bays in the terminal/interchange or on-street lay-bys or parking spaces at appropriate locations. If lay-bys are provided specifically for non-franchised buses, they should be of the same standard as those for franchised buses. Chapter 2 of this Volume should be referred to in respect of the standard of provision.
- (ii) Scheduled service may also be permitted to use existing transport terminals/interchange where spare capacity is available.
- (iii) New school and hotel developments are, however, required to provide spaces within the development for coaches to pick up and set down passengers. The Hong Kong Planning Standards and Guidelines should also be referred to for the details of standard of provision.
- (iv) Housing estates which operate their own residents' service should provide the terminal facilities within the estate development as far as possible.
- (v) Interchange facilities for the exclusive use of a particular non-franchised bus operator are not normally provided by the Government. However, upon application, and where the demand and the scale justify, consideration may be given to assisting the operators concerned in their

applications to the Lands Department for sites to be used as off-street bus termini.

6.3.3.2 Cross-Boundary Coach Service Termini

- (i) Most of the cross-boundary coach routes terminate and pick up / set down passengers on-street. A number of off-street cross-boundary coach terminus (CBCT) projects are committed. However, with the projected growth in demand for cross-boundary coach services, there will be a need for additional new sites to meet the demand for CBCT facilities and to replace existing on-street facilities in a progressive manner.
- (ii) Existing cross-boundary coach routes are spread out in the territory and there is a general reluctance of the operators to move away from their established catchment. In identifying new sites, the aim should be to decentralize the provision of CBCT by providing a greater number of medium-sized CBCT (say 5-10 coach bays) as part of public transport interchanges at suitable locations which will provide the cross-boundary coach service users with convenient connection with other transport services. The CBCT facilities should also be at affordable cost to the operators. In addition, the following factors have to be taken into account :
 - (a) accessibility;
 - (b) the types of vehicles using the terminus, e.g. right-hand drive, left-hand drive, or both;
 - (c) the availability of connecting public transport services;
 - (d) the maximum number of vehicles likely to use the terminus at any one time;
 - (e) the coach lay-over time to be permitted or required;
 - (f) land availability;
 - (g) the capacity of adjacent roads;
 - (h) the environmental impact on neighbouring developments; and
 - (i) scope for future expansion.
- (iii) Cross-boundary coach services should supplement the railway services from / to Lo Wu and Lok Ma Chau Spur Line Control Points and High Speed Rail. To avoid possible conflict and confusion arising from passengers choosing between the cross-boundary coach and the railway services, it is preferable to consider the spatial separation between a CBCT and relevant rail stations.
- (iv) In drawing up the detailed design of an off-street terminus, the following points may need to be considered :
 - (a) Designation of the ingress and egress points be conveniently located in connection with the adjacent road network;
 - (b) Provision of public utilities, e.g. water, electricity, gas, telephone; and
 - (c) The facilities should be reasonably sized, comprising air-conditioned regulator cum ticketing office and passenger waiting facilities and toilets, with an area approximately 20-25 sq. metres per coach bay.
- (v) Reference can be made to Chapter 2 of this Volume for the terminus layout. However, the internal design of the terminus will need to take account of the fact that coaches using the

terminal facilities will consist of both right-hand and left-hand steering vehicles having left-side and right-side entrances/exits respectively. Bays, and the arrangement of these bays, and adjacent platforms will therefore need to be designed accordingly.

- (vi) Internal circulation aisles, access roads, and bays should be designed to accommodate 12-metre length buses, and the headroom where any part of the terminus is built over should be at least 5.1 metres. This is a standard height of covered terminus with no ventilation plant for double-deck buses. If ventilation plant is built, the headroom should be at least 6.0 metres.
- (vii) Diagram 6.1 illustrates the layout of the Sai Wan Ho cross-boundary coach service terminus which has included some of the following essential facilities to serve passengers :
 - (a) Administration and Passenger Areas
The terminus may consist of offices, ticketing hall, covered passenger waiting lounge, public reception area, telephone booths, washrooms and kiosk. Space/facilities may need to be provided for the display of public transport passenger information.
 - (b) Boarding/Alighting Area
The boarding/alighting areas should be located near passenger waiting area. Raised platforms in between the loading/unloading bays should be provided so as to facilitate boarding and alighting via the left-hand or right-hand doors of buses. Where a platform is to be used by both left-hand and right-hand drive vehicles, double-width bay should be provided as far as possible. To facilitate coach/rail interchange, one to two triple-width loading bays each of 40 metres long with a passenger platform along both sides of the bays for cross-boundary coaches should be provided if feasible. A low parapet wall at the end of the bay protecting passengers on walkways may be required.
- (viii) The Government should be responsible for providing the basic CBCT facilities, covering the fitting out and maintenance cost of these facilities e.g. coach bays, terminal lighting and ventilation, cleansing and road service maintenance :
 - (a) the capital costs of the basic terminal facilities should be provided under project vote; and
 - (b) the relevant departments should carry out maintenance of these CBCT facilities as part and parcel of the PTI maintenance.
- (ix) The cross-boundary coach service operators should be responsible for the capital and recurrent costs (e.g. lighting, air-conditioning and cleansing) for the passenger facilities in the CBCT. These passenger facilities should be scaled down to a reasonably sized, air-conditioned regulator/ticketing office with passenger waiting facilities.
- (x) The above financial arrangement is in line with the existing practice of Government providing loading bays in PTIs for public light buses, taxis and non-franchised buses etc. without charging for the use of these facilities. On the other hand, the cost for any additional passenger facilities on top of the basic CBCT requirements will be borne by the operators themselves in accordance with the user-pay principle.
- (xi) Where termini are established in accordance with paragraph 6.3.3.2 (ix) or 6.3.3.2 (x), any endeavours to establish alternative management arrangements in the termini should not be authorized, and be discouraged, to avoid disputes or conflicts. Coach bays in CBCT shall be designated in consultation with relevant cross-boundary coach operators.

- (xii) Under this mode of operation of CBCT, the CBCT passenger facilities would require some regulation to ensure that they are properly used and not monopolized by any group, and hence a suitable management arrangement would be put in place. Consultation with the relevant cross-boundary coach operators is necessary to work out the best arrangement to facilitate the management of the facilities. In general, the users of CBCT passenger facilities should take up the management responsibility which shall be stipulated in the maintenance schedule of the premises.
- (xiii) The management of the passenger facilities of new CBCT could be incorporated into TD's car park contracts.

6.3.3.3 Residents' Service Termini

- (i) To allow for flexibility, a bus terminus with proper bays and passenger platforms or lay-by(s) inside a housing estate should be designed in such a way that it can be converted into general purpose loading/unloading bays to facilitate the operation of residents' services if needed.
- (ii) The design of the termini for residents' services would be similar to those of franchised services. To optimize the use of the termini, it may also be used for other services which are operated at relatively low frequencies (say half-hourly).
- (iii) Where a terminus is provided beneath a building development, the design of the layout may be constrained by site conditions and the building grid. It may then be necessary to adopt the use of parallel bus bays or kerbside stopping in order to provide an acceptable design.
- (iv) Off-street residents' service terminus may not be provided due to the shortage of land for loading/unloading purposes. As for some common destinations such as Tsim Sha Tsui and Admiralty etc., consideration may be given to provide loading/unloading points when opportunities arise through traffic management control. Normally the operator would be expected to make use of existing lay-bys provided for general traffic or loading/unloading areas designated specifically for coaches and buses. Where lay-bys are utilised, the layover of buses should not be allowed as this will restrict the use of the lay-bys by other vehicles causing them to stop on the carriageway.

Diagram 6.1: Layout Of Sai Wan Ho Cross-Boundary Coach Service Terminus

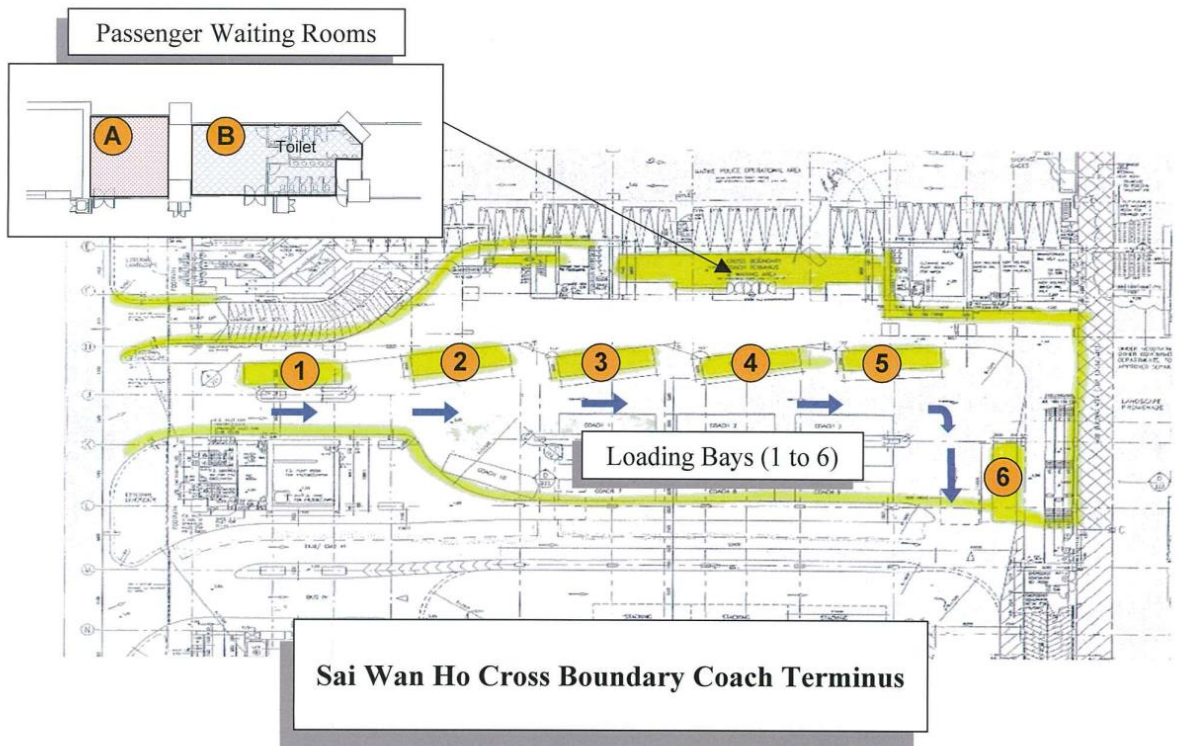

6.3.4 Stopping and Parking Facilities

6.3.4.1 General

- (i) There is no specific provision under the current legislation to provide on-street bus stops for the exclusive use of non-franchised buses, nor are they permitted under the regulations to stop at designated bus stops for franchised buses or public light buses or scheduled service buses.
- (ii) Non-franchised buses may, as other vehicles can, stop their vehicles to pick up/set down passengers in any street where stopping restrictions are not imposed or in any period when the stopping restriction is not effective. However, for scheduled services providing international passenger, residents' service, multiple transport services, they are only permitted to stop at designated stops in accordance with the approved schedules of services.
- (iii) There is also no authority for operators to erect signs to indicate where non-franchised services will stop. An operator erecting any such signs without approval from the Commissioner would commit an offence under Section 51 of the Road Traffic Ordinance.
- (iv) Parking facilities should be provided, if condition permits, to facilitate the operation of non-franchised buses.
- (v) In accordance with section 5(1) of Road Traffic (Parking) Regulations (Cap. 374C), the Commissioner may designate any place on a road or any place to which vehicles have access as a parking place by means of road markings. There are locations in the Territory where off-street or on-street public parking spaces are specifically designated for buses only.
- (vi) Under the Fixed Penalty (Traffic Contravention) Regulations, again as with other vehicles, parking on pavements, pedestrian ways, central reservations, verges, or traffic islands is prohibited.
- (vii) Off-street parking facilities for non-franchised buses should be provided at the operator's depots, or off-street parking sites

6.3.4.2 Cross-Boundary Coach Service

- (i) Cross-boundary coach service should be operated in accordance with the approved routing and stopping point. Therefore, hail and stop arrangements normally do not apply.
- (ii) If it is agreed that intermediate stops for a cross-boundary coach service are appropriate, careful consideration should be given to the locations of the stops. Passengers on the service will generally be accompanied by luggage and therefore footways adjacent to the stop should be wide enough to allow passengers to wait without interfering with the movement of other pedestrians. The minimum width of the footway identified for intermediate stops for a cross-boundary coach service should be determined in accordance with TPDM Volume 6 Chapter 10 Section 5 and Table 10.5.5.1. Depending on the type of frontage development e.g. residential, commercial, industrial, rural, etc. and the development intensity, the minimum width of footway ranging from 2 metres to 4.5 metres should be increased by 1 metre in the vicinity of bus stop and by 2 metres where bus shelters are erected as far as practical. It is also advisable to have the level difference between the bus bay and the passenger platform not to exceed 150 mm in order to avoid accidental slipping of passengers, especially the elderly and children, onto the bus bay while waiting for the bus. Besides, these coaches will take longer time than other buses to pick up or set down passengers as luggage will need to be loaded/unloaded from a separate

compartment, it therefore should be ensured that this will not seriously affect traffic and pedestrian circulation.

6.3.4.3 Residents' Service

- (i) According to the “General Principles that should be Considered in Processing Applications for New Residents' Service”, new residents' service should be processed with due regard to the following :-
- (a) the residents' service should facilitate commuters to connect to the nearby rail station or public transport interchange to avoid adding congestion to busy urban districts;
 - (b) the residents' service should not pose a significant adverse impact on regular public transport services in the area concerned;
 - (c) the operation of the proposed residents' service should only be approved when the existing or planned public transport services in the area concerned are inadequate or limited;
 - (d) the operation of the proposed residents' service should only be approved when the residential developments served by the proposed residents' service are distant from rail stations, public transport interchanges or major franchised bus stops or GMB stops and use of alternative services will result in an excessive number of interchanges; and
 - (e) the proposed residents' service will not operate in congested areas or via local busy roads and will not cause traffic congestion.

The designation of stopping places for residents' service is to facilitate passengers to get to and return from their destinations, rather than catering for the en-route transport demand. The number of stops therefore must be limited.

- (ii) Residents' service buses are required to stop at designated locations to pick up / set down passengers as stipulated in the approved Schedule of Service. Stop signs have been erected by Transport Department at some designated locations to indicate the route numbers of residents' service buses that are permitted to stop there for picking up / setting down passengers, and to facilitate Police's enforcement against unauthorized residents' service operation. An illustration of such a sign is given in Diagram 6.2.
- (iii) The stopping places observed by a residents' service are usually proposed by the operator, and vetted by the Regional Transport Operations Divisions of the Transport Department. The Regional Traffic Engineering Divisions are consulted from the traffic engineering point of view.
- (iv) Chapter 2 of this Volume provides guidance as to the location of bus stops for franchised buses, and similar considerations should be given to the location of stopping places for residents' services.

Diagram 6.2: Sample of stop sign for residents' service

居民巴士站

Residents' Service Bus Stop

九龍公園徑

Kowloon Park Drive

上客路線 Boarding			落客路線 Alighting		
□	NR700	□	NR30	NR700	□
NR740	□				

經營未經運輸署批准的居民巴士服務屬違法，並可能使有關車輛的第三者意外保險失效。

The operation of a residents' bus service without the Transport Department's approval is an offence and may invalidate the third party risk insurance in respect of the motor vehicle concerned.

TPDM Volume 9 Chapter 7 – Ferries

7.1 References

- 1 Ferry Services Ordinance, Cap. 104
- 2 Merchant Shipping (Local Vessels) Ordinance, Cap. 548
- 3 Hong Kong Planning Standards Guidelines, Chapter 8, Internal Transport
- 4 Transport Planning Design Manual Volume 2, Highway Design Characteristics
- 5 Transport Planning Design Manual Volume 3, Traffic Signs and Road Markings
- 6 Transportation Research Circular, Interim Materials on Highways Capacity, Pedestrians

7.2 Introduction

7.2.1 Preamble

The regulation and control of franchised & licensed ferry services within the waters of Hong Kong is under the Ferry Services Ordinance, Cap. 104.

7.2.2 Ferry Services Ordinance, Cap. 104

7.2.2.1 Ferry services may be either franchised services regulated under Parts III and IV of the Ferry Services Ordinance, or licensed services regulated under Part VI of the Ordinance.

7.2.2.2 The Ordinance defines a ferry service as "a service provided by means of a vessel, other than a vessel exclusively propelled by oars, for the conveyance by water of passengers, baggage, goods or vehicles, for reward at separate fares between 2 or more points within the waters of Hong Kong, whether or not such points are varied from time to time and whether or not the service is operated to a fixed timetable".

7.2.2.3 Tour services, cargo services, employees' services and permitted services, as defined in Section 5 of the Ordinance, are exempted from the requirement to apply for a franchise or a licence.

7.3 Ferry Services

7.3.1 Franchised Services

7.3.1.1 Under section 6 of the Ferry Services Ordinance, Cap. 104, the Chief Executive in Council may grant to any company a franchise that confers the right to operate a ferry service between such points as are specified by him.

7.3.1.2 At present, the “Star” Ferry Company Limited (SF) is the only franchised operator and operates two cross-harbour ferry services under its franchise till 31 March 2033.

7.3.2 Licensed Services

7.3.2.1 Under section 28 of the Ferry Services Ordinance, Cap. 104, the Commissioner may grant to any person a licence to operate a ferry service between such points as specified in the licence. Vessel licences are issued by the Director of Marine under the Merchant Shipping (Local Vessels) (Certification and Licensing) Regulation (Cap. 548D).

7.3.2.2 The ferry services in Hong Kong including cross-harbour passenger ferry services and passenger ferry services for outlying island are operated under ferry service licences by Sun Ferry Services Company Limited (Sun Ferry), Hong Kong & Kowloon Ferry Limited (HKK), Fortune Ferry Company Limited (Fortune Ferry) and the Discovery Bay Transportation Services Limited (DBTSL).

7.3.2.3 Due to safety reason, dangerous goods vehicles are prohibited from using road tunnels in Hong Kong. At present, Hongkong and Yaumati Ferry Co. Ltd. (HYF) operates two dangerous goods vehicular ferry services “North Point - Kwun Tong” and “North Point/ Kwun Tong - Mui Wo/Kau Shat Wan”.

7.3.2.4 ‘Kaito’ is a licensed service under Cap.104, which plies in the remote areas of Hong Kong to serve the local transport demand where land transport is inaccessible. Either launches or primitive vessels licensed by the Director of Marine under the Merchant Shipping (Local Vessels) (Certification and Licensing) Regulation (Cap.548D) and Merchant Shipping (Local Vessels) (Safety and Survey) Regulation (Cap 548G) may be used as ‘kaito’. When a launch or a primitive vessel obtaining a licensed service from the Commissioner, relevant vessel operating licence will be issued in accordance with Cap. 548D for allowing it to carry passengers within the designated kaito routes.

7.4 Ferry Vessels

7.4.1 Licensing

7.4.1.1 The Director of Marine is the licensing authority for ferry vessels. The Director of Marine exercises its control over the licensing of ferry vessel under Part IV of the Merchant Shipping (Local Vessels) Ordinance. (Cap. 548).

7.4.1.2 Vessels used for the operation of franchised services, licensed services and kaito services are licensed under the Merchant Shipping (Local Vessels) (Certification and Licensing) Regulation (Cap 548D) and Merchant Shipping (Local Vessels) (Safety and Survey) Regulation (Cap 548G).

7.4.2 Deployment

7.4.2.1 The decision to deploy a particular type of vessels on ferry routes is dictated by factors such as:

- (a) passenger demand or financial viability of this routes;
- (b) suitability of pier such as design loading of the pier structure, travelling distance of lift and ramp;
- (c) suitability of the vessel such as draft of vessel;
- (d) local operation conditions.

7.4.2.2 Agreement should be obtained from:

- (a) Civil Engineering and Development Department
(Aspects in relation to structure design or loading of pier structure below deck)
- (b) Marine Department
(Marine operational aspects)

7.4.2.3 For general guidance, the allowance to be made for the draft of various fully loaded vessels is indicated in Table 7.4.2.1.

Table 7.4.2.1
Vessel Draft Allowance

Vessel Type	Allowance for Draft (m)
Vehicular Ferries	4.3
Double-Ended Double-Decked Ferries	3.4
Triple-Decked Ferries	3.6
Catamarans	2.3

7.4.3 Carrying Capacity

7.4.3.1 The carrying capacity of a ferry vessel is determined by Marine Department pursuant to the Merchant Shipping (Local Vessels) (Safety and Survey) Regulation (Cap.548G).

7.5 Ferry Piers

7.5.1 Standards for Ferry Piers

- 7.5.1.1 Ferry piers may be constructed by the Civil Engineering and Development Department, Architectural Services Department or the ferry operators themselves.
- 7.5.1.2 The size of a ferry pier and the form it takes will depend on the number and type of ferry services expected to use the pier, the frequency of the service(s), the anticipated passenger volume and the type of ferry vessels to be deployed on the service(s).
- 7.5.1.3 Standard finger piers (with two berths) are the most common form of piers, but smaller piers such as stub piers (providing one berth for alongside berthing) or larger piers, e.g. four-berth piers, may be built depending on the projected requirement of the ferry services using the pier. Diagram 7.5.1.1 to Diagram 7.5.1.4 are drawings of typical passenger and vehicular ferry piers.
- 7.5.1.4 Landing facilities may also take the form of pontoons moored against the seawall. Such arrangements are usually adopted where proper ferry pier facilities are not available, e.g. in Aberdeen and Joss House Bay, or may be interim measures adopted prior to the availability of proper ferry pier facilities. Pontoons may also be used during the introductory stage of a new service to test the market demand so as to avoid investing heavily in the constructing of permanent pier facilities.
- 7.5.1.5 Linkspan is a ramp type structure, which provides a loading and unloading facility between a ship and the shore. It derives its support from the shore, the seabed, the ship, buoyancy, or a combination of these elements. The linkspan system must be able to accommodate the ship movements described earlier, without causing an unsafe situation to arise. Manually activated power or buoyant movements of the structural part of the system are designed to accommodate such movements.
- 7.5.1.6 The ship-to-shore linkspan usually consists of two elements:
- a ramp from the shore to some point near the ship; and
 - a ramp on the ship connecting the shore ramp and the ship.
- 7.5.1.7 The shore ramp is usually designed to move up and down with the tide and major changes in the ship's draught. The ship's ramp is used to accommodate the smaller, but faster, movement caused by the ship's motion, particularly rolling and pitching.
- 7.5.1.8 The ship ramp is hinged on the ship and lowered onto the shore ramp. A finger flap is usually provided to allow a smooth transition between the two ramps. A finger flap is a narrow, usually steel, flap attached to a ramp, or even a walkway. A typical arrangement with two berths is shown in Diagram 7.5.1.5.
- 7.5.1.9 The Civil Engineering and Development Department and Architectural Services Department are the authorities on the structural design of ferry piers while the architectural layout is governed by the requirements of Transport Department and other concerned parties. Generally speaking, facilities on passenger ferry piers should include segregated waiting areas for each deck, turnstiles, ticketing office, staff rooms and public toilets. All plumbing, drainage pipes and associated facilities and fittings serving the pier shall be laid above the pier deck with proper access for future maintenance, and the design shall be submitted to respective maintenance agents for comments prior to construction. The size of waiting area should refer to the type of vessel to be used. A schedule showing the various levels of passenger waiting area provision is at Table 7.5.1.1. The normal practice is to provide passenger waiting areas inside the 'paid area' of a pier for one and a half boat-loads of passengers, applying the level 'E' standard, i.e. 0.28 square metre per person.

7.5.1.10 The design of ferry piers and their adjacent concourses should provide barrier-free facilities for people with disabilities with reference to Volume 6 Chapter 8 of this TPDM and adequate space that is available for pedestrian circulation without conflict with vehicular traffic. In addition, there should be an uninterrupted covered pedestrian access connecting the ferry piers and nearby activity centres. In general, public transport interchanges may be provided in the vicinity of all major ferry piers to facilitate travel between the ferry piers and the commercial or residential area in the vicinity of the pier. For vehicular ferry piers, adequate vehicle waiting areas segregated from other traffic should be provided. The general guideline is to provide waiting areas adequate to accommodate 1.5 boat-loads of vehicles.

Table 7.5.1.1
Level of Services Schedules for Passenger Waiting Areas

Level of Service	Area per person (m ²)
A - Desirable area for standing and free circulation	1.5
B - Adequate area for standing but some restriction on circulation	1.2
C - Sufficient standing area but circulation restricted	0.93
D - Standing area may be affected by circulating pedestrians	0.65
E - Circulation extremely difficult	0.28
F - Body contact when standing, no circulation	0.19
G - Close body contact and physical and psychological discomfort	0.14

7.5.2 Siting of Ferry Piers

7.5.2.1 The physical suitability of a site for construction of a ferry pier is determined by factors such as water depth, exposure to wind/wave, water currents, existence of sewage/drainage outfalls, etc., and by Marine Department who will consider aspects such as the possible effects of the pier on adjacent marine activities if any and the routeing of ferry services which are to operate from the pier.

7.5.2.2 From Transport Department's point of view, the main consideration as to whether a site is suitable for construction of a ferry pier is the attractiveness, and accessibility in terms of the catchment area it is intended to serve.

7.5.2.3 The attractiveness and accessibility of a site is particularly important for passenger ferry piers, where the location of the piers, the land use zoning/development of the adjacent areas and the availability of feeder services and covered walkways are important factors affecting this and hence the financial viability of the ferry services operating from the piers.

7.5.2.4 In recognition of the ferries' role in easing road congestion and reducing the call on road transport, the White Paper on Internal Transport Policy published in 1979 laid down the following guidelines (para. 117 of White Paper): -

- (i) good feeder transport services to ferry piers are essential;
- (ii) ferry piers should be within easy walking distance of passengers; and
- (iii) land in the immediate vicinity of ferry piers should be zoned, wherever possible, for residential/commercial usage.

7.5.2.5 In most cases, walking is the predominant mode of travel to and from passenger ferry piers. Hence, apart from the guideline in paragraph 7.5.2.4 (ii) above, the provision of covered walkways leading to ferry piers is very important, especially now that new piers are mostly sited on newly reclaimed areas which can be, during the initial stages of development at least, some distance from the local population centres. In such instances, covered walkways considerably improve comfort to passengers and encourage more people to use public transport services.

- 7.5.2.6 It is desirable to provide covered walkways to link the pier to any nearby transport interchange and to areas of demand concentration as these develop, even though they may be temporary in advance of permanent development in the anticipated future development. For the details of the covered walkway design, refer to Volume 2 Chapter 3 Section 3.4.11.
- 7.5.2.7 In considering the location of future piers proposed on development plans, attention should be paid to locating activities which will generate transport trips close to the piers so that best use is made of the ferry facilities.
- 7.5.2.8 Where possible, land in the immediate vicinity of ferry piers should be zoned for traffic-generating uses such as commercial, residential, entertainment and industrial (para. 7.5.2.4 (iii) above) so that the walking distance to the piers is minimised.
- 7.5.2.9 Bus/PLB termini and taxi stands are usually provided at major ferry concourses, as the provision of good land feeder services is necessary to promote the use of ferry services (para. 7.5.2.4 (i) above). Additionally in this respect it is advantageous to site Ferry Piers close to major transport interchanges such as railway stations.
- 7.5.2.10 The phasing of developments in the vicinity of ferry piers should be carefully programmed to ensure timely development of catchment areas for the ferry services, particularly where a pier has been relocated to the edge of a new reclamation. Good feeder services and covered walkways play a particularly important role in maintaining ferry patronage in these instances.
- 7.5.2.11 In addition to the above, other considerations are that the road network adjacent to ferry piers should be adequate to handle the anticipated volume of traffic (pedestrian and vehicular), and in particular the vehicular traffic generated by vehicular ferry piers.
- 7.5.2.12 The internal road layout at ferry piers should be in accordance with the road standards given in Volume 2. The headroom clearance for any overhead structures within vehicular ferry piers and waiting areas should not be less than 3.5 m which is the headroom of the lower deck of vehicular ferries and preferably in accordance with Table 3.5.1.1 of Volume 2. Vehicular ferry piers should be sited where the road access to and from the pier is convenient.
- 7.5.2.13 Adequate directional signs, including those for “Water Taxi” licensed ferry service, should be provided guiding both passengers and vehicles to ferry piers. This is particularly important for vehicular ferry piers and for new or newly resited ferry piers. Guidelines for directional signs are set out in Volume 3 Chapter 3.

DIAGRAM 7.5.1.1: FINGER AND STUB PIER

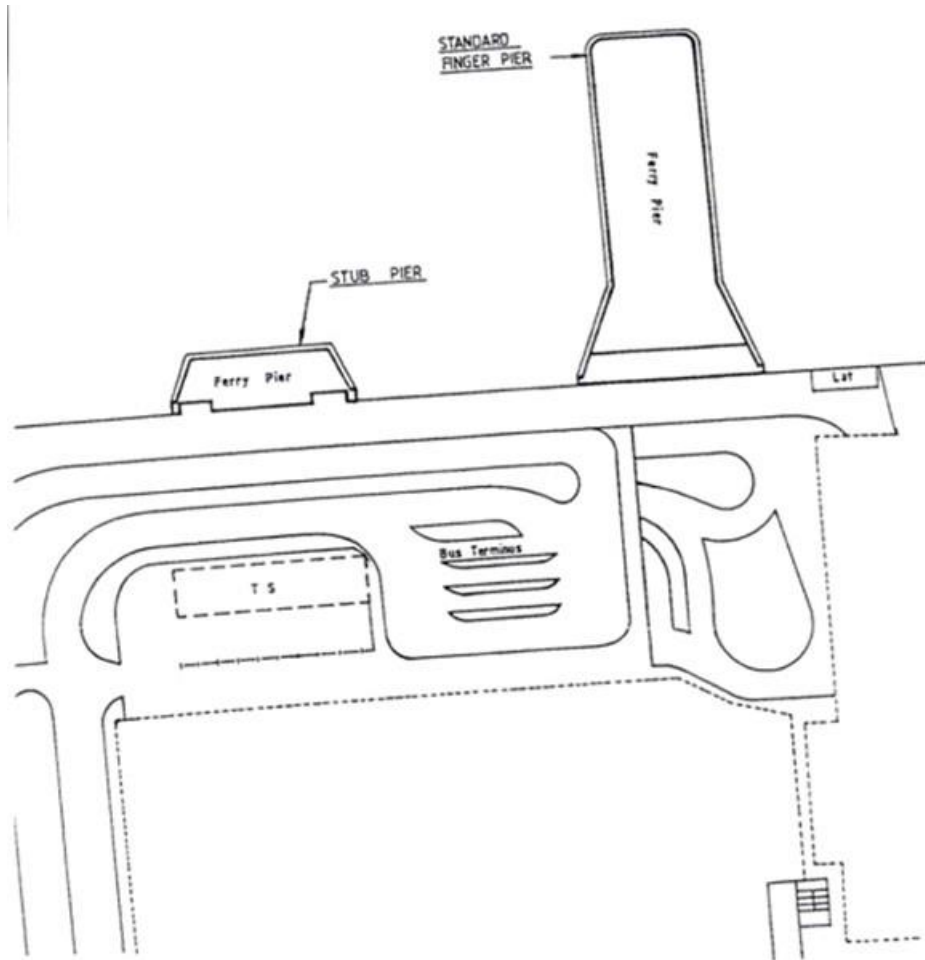

DIAGRAM 7.5.1.2: FOUR-BERTH PASSENGER FERRY PIER

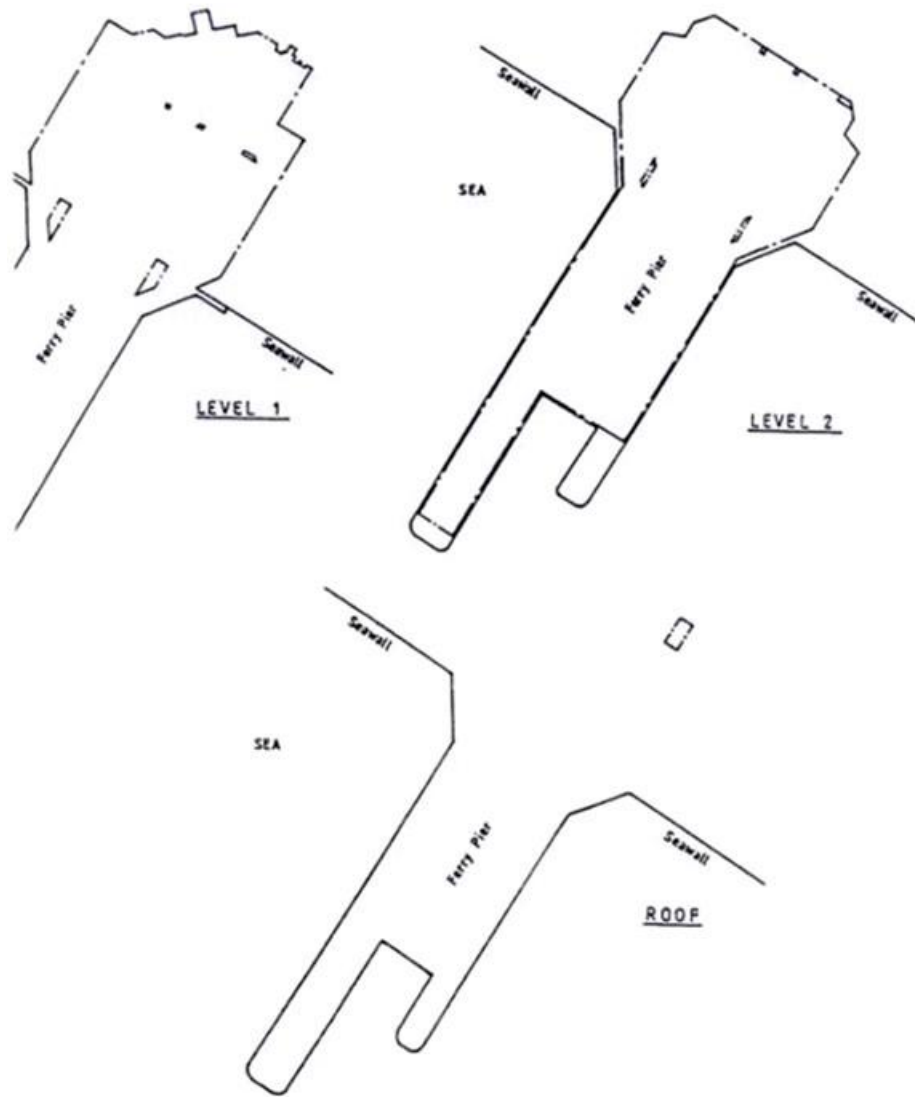

DIAGRAM 7.5.1.3: VEHICULAR FERRY PIER

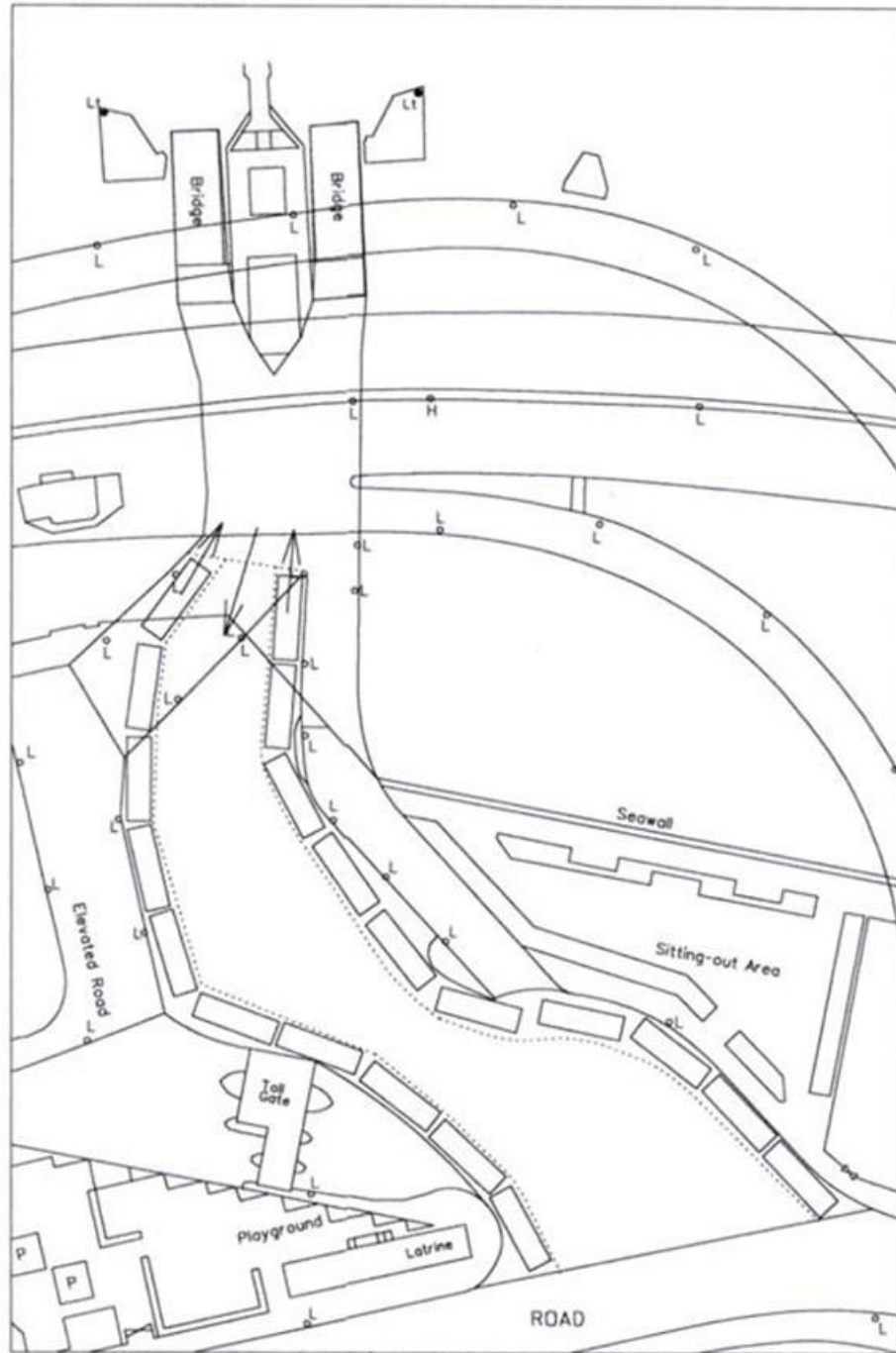

DIAGRAM 7.5.1.4: PASSENGER-CUM-VEHICULAR FERRY PIER

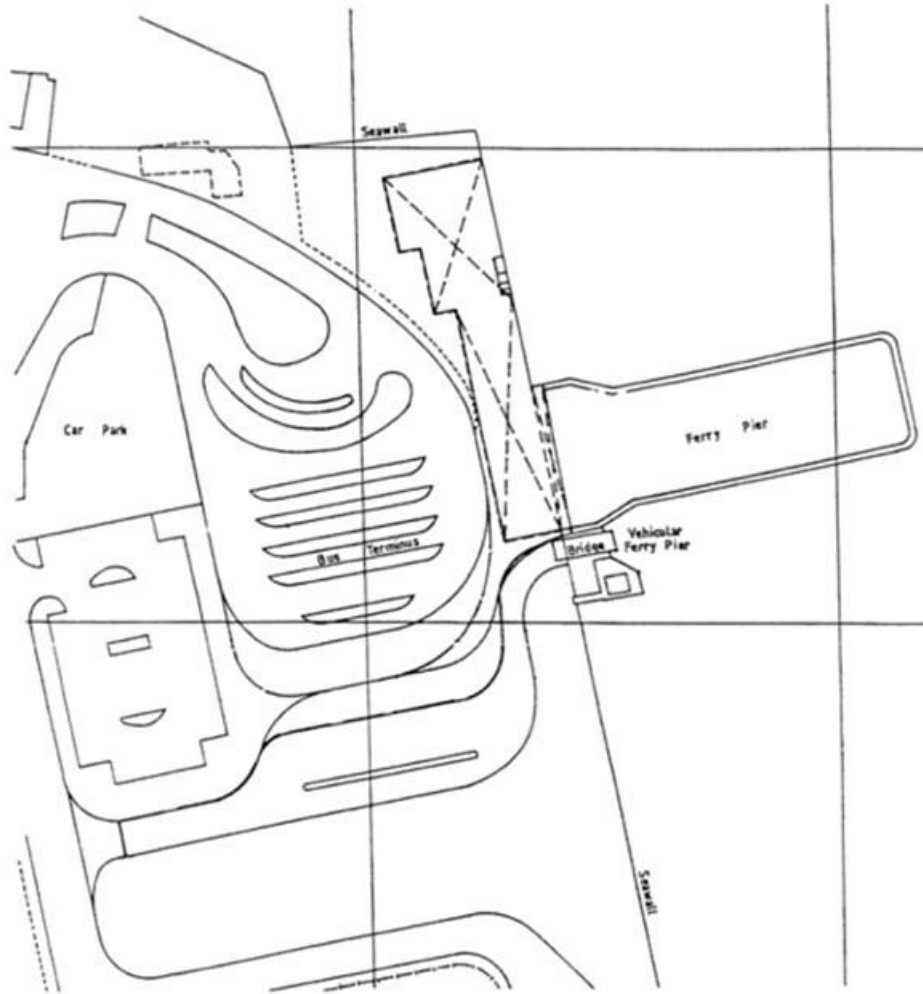
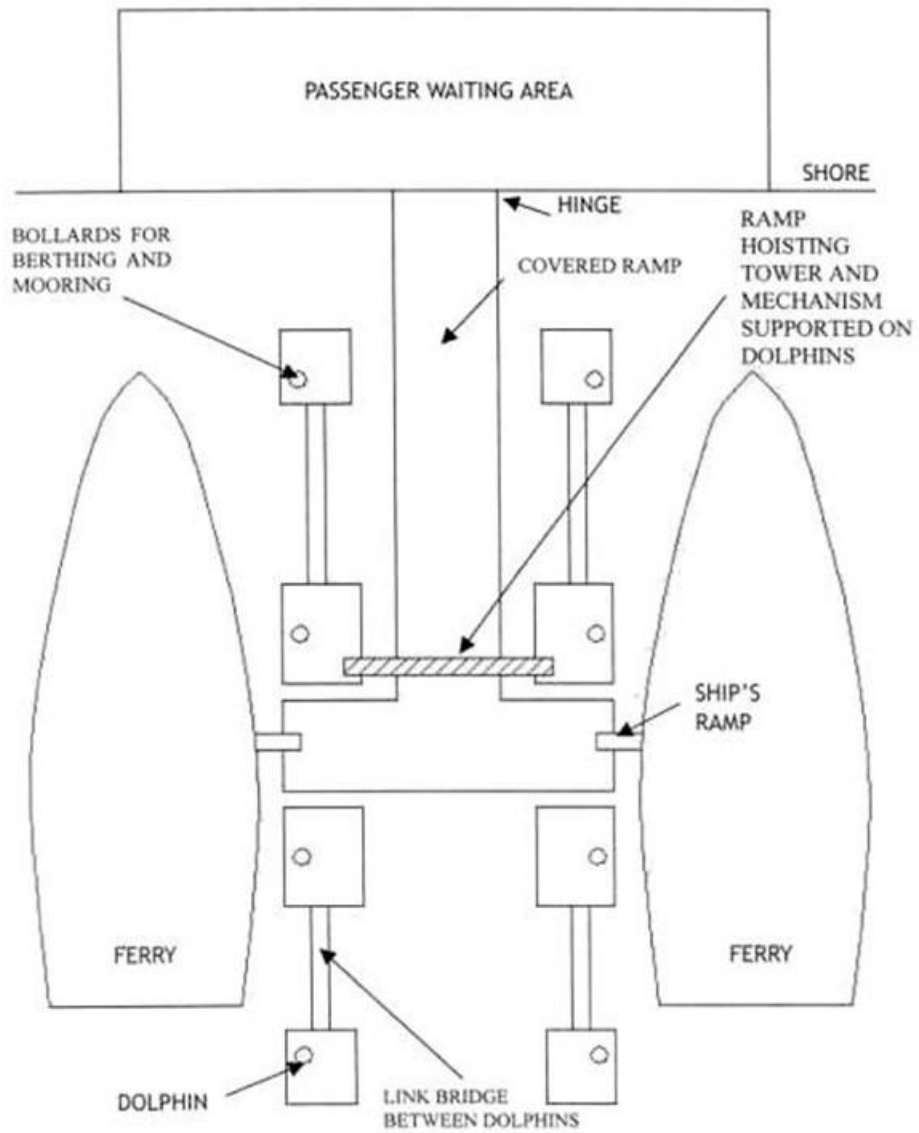

DIAGRAM 7.5.1.5: Typical Linkspan Arrangement (Two Berths)



Typical Linkspan Arrangement (Two Berths)

TPDM Volume 9 Chapter 8 – Public Transport Interchange

8.1 References

1. Calton C.C. (1986) *Urban Transportation Systems and Transport Interchange* (papers presented at the Sino-British Highways and Urban Traffic Conference in Beijing), U.K.
2. Confederation of British Road Passenger Transport (1981) *Urban Planning and Design for Road Public Transport*, U.K.
3. Environment Branch, Government Secretariat (May 1979) *Keeping Hong Kong Moving: The White Paper on Internal Transport Policy*, HKSAR.
4. Institute of Transportation Engineers (1992) *The Location and Design of Bus Transfer Facilities*, Washington D.C.
5. Institute of Transportation Engineers (1992) *Transportation Planning Handbook*, Washington D.C.
6. Maltby D and Cheney C.N. (April 1971) *Factors affecting the design of transport interchanges*, Traffic Engineering & Control, U.K.
7. Millward C., Coletian A.H. and Dunford J.E. (August/September 1974) *Passenger transport interchanges on Merseyside: results and conclusions*, Traffic Engineering & Control, U.K.
8. Planning Department *Hong Kong Planning Standards and Guidelines*, Chapter 8 - Internal Transport Facilities, HKSAR
9. Steer J.K. (August/September 1979) *Factors influencing the planning and design of bus terminals*, Traffic Engineering & Control, U.K.
10. Suen, S. Ling and C.G.B. Mitchell. (January 2000) *TRB Millennium Papers - Accessible Transportation and Mobility for the New Millennium*, Washington D.C.
11. Transport Branch, Government Secretariat (January 1990) *Moving into the 21st Century: The White Paper on Transport Policy in Hong Kong*, HKSAR
12. Transport Department (1999) *The Third Comprehensive Transport Study: Technical Report*, HKSAR
13. Transport Department (2000) *Studies on Coordination of other Public Transport Services with New Railways: Working Paper No. 9 - Design Guidelines for Public Transport Interchanges*, HKSAR
14. Transport Department (2020) *Departmental Circular No. 4/2020 - Guideline on Designating Column-Free Areas in New Covered Public Transport Interchanges*, HKSAR
15. Transport Research Laboratory (1994) *TRL Project Report 83 - Design Guidelines for Public Transport Infrastructure*, U.K.
16. Transportation Development Centre, Transport Canada (May 1998) *Making Transportation Accessible : A Canadian Planning Guide*, Canada.

8.2 Introduction

- 8.2.1 The majority of the person trips in Hong Kong is by public transport. Although the preference is for a trip to be completed using a single mode, this is not always possible in a complex urban environment. Hence, there may be situations where passengers use more than one transport mode to complete a journey.
- 8.2.2 Passenger interchanges may take place between different road based modes, between road based and non-road based modes, as well as between non-road based modes such as ferry and rail services. While interchanges would mainly take place at bus termini, ferry terminals or railway stations, it may also occur at on-street bus stops.
- 8.2.3 The effectiveness of an interchange may be affected by location suitability, facilities design, transfer efficiency and passenger convenience. A highly efficient interchange is to fulfill objectives such as to minimize waiting and walking time for passengers, eliminate passenger/passenger conflicts and passenger/vehicle conflicts, minimize dwell time for public transport carriers and eliminate vehicle/vehicle conflicts.
- 8.2.4 The White Paper on Transport Policy published in 1990 reiterates the Government's view that there should be a balanced network of public transport services with emphasis on more and better use of the efficient carriers. i.e. buses and trains, supplemented by other modes providing complementing services.
- 8.2.5 Based on the findings of the Third Comprehensive Transport Study (CTS-3), a "Hong Kong Moving Ahead – A Transport Strategy for the Future" was published by Government in October 1999. One of the major transport strategies is to encourage the maximum utilization of railways which will become the backbone of Hong Kong's passenger transport system. Franchised bus and other public transport services will continue to play an important role in areas not accessible by railways as well as feeding passengers to railways. To improve public transport services and to ward off pressure for proliferation of long-haul routes, it is Government's policy to introduce a limited number of long-haul routes and provide more bus-bus and bus-rail interchanges as far as possible. These prevailing policies would have bearings on the design and configuration of public transport interchanges (PTIs), particularly for major PTIs serving railway stations. For a co-ordinated public transport system to be attractive and efficient, opportunity should be taken to plan for a network of high standard PTIs.

8.3 Project Planning

- 8.3.1 A public transport interchange (PTI) can be defined as an area which may contain a rail station, bus bays, taxi stands, public light bus (PLB) stands, resident's services lay-bys, private cars lay-bys and possibly park and ride facilities where people interchange between services and modes.
- 8.3.2 The major issues to be considered in planning for a PTI project include the overall function of the transfer facility and how it fits into the larger transportation system, the need to develop an off-street, or other higher capacity facility, and the opportunity for joint transit/land use development.
- 8.3.3 Proposals for new PTIs comprise elements of the town planning process and they may be incorporated in the public works program. The identification of new PTIs may come about in several ways as follows:
- components of transport studies such as the sub-regional transport studies or the railway development studies as specified by consultants;
 - planning briefs circulated by Planning Department or Housing Department for new developments and redevelopment of older housing estates; and
 - direct requests to Planning Department or Housing Department if outside the scope of development or redevelopment proposals.
- 8.3.4 It is particularly important to make an early definition of the intended size and scope of a new public transport interchange having regard to the ultimate demand or at least for a long time frame say 10 years of the transport services. In additions, it is essential to consult in the early stages those parties who will eventually manage and operate the interchange so as to commit resources for its future management and maintenance.
- 8.3.5 Theoretically, PTIs should be provided off-street as far as possible for the following reasons:
- to avoid disruption to traffic;
 - to provide proper queuing areas for passengers;
 - to provide terminal space for operators; and
 - to provide a vehicular turn round facility.

8.4 Design Requirements for Public Transport Interchange

- 8.4.1 In designing PTI, consideration should be given to land availability, cost, road network, planning development and details of the public transport services such as number of vehicles, headways, layover requirement, platform arrangements and modal interfaces. To cater for services from a wide area where interchanges will take place, operational and passenger facilities will have to be taken into account.
- 8.4.2 The general design requirements for PTI provisions shall include the following but they are not necessarily a list of essential requirements as they depend on the location, size, nature and surrounding environment of an interchange:
- integrated design of PTI
 - provision of adequate capacity for terminating and passing buses or minibuses
 - provision of column-free area for reducing obstruction to and enhancing safety of public transport operations (Departmental Circular No. 4/2020);
 - use of raised platform in association with low floor buses with a kneeling facility
 - minimisation of walking distances between services and modes
 - provision of people movers, lifts and escalators, and ramps for long walks, level differences and people with special needs respectively
 - provision of adequate directions for passengers, particularly first time passengers
 - provision of covered walkway
 - provision of adequate pedestrian network with safe environment including adequate capacity and lighting, weather protection (air-conditioning and/or good ventilation), crossing facilities, minimisation of pedestrian-vehicular conflicts and personal security
 - provision of crossing facilities to facilitate bus captains accessing the bus stacking areas, bus loading bays and staff ancillary facilities
 - provision of on-line real time passenger information system
 - provision of staff and use of CCTV for information and security purposes.
 - provision of congenial waiting environment with adequate capacity seating and quality information on services
 - provision of facilities including kiosks, refreshment facilities, toilets, newsagents and retails
- 8.4.3 A summary of key features and facilities which should be taken account in designing the PTIs can be grouped into 8 main categories.
- Patronage and Pedestrian Demand – Volume and mode split of passenger/pedestrian traffic at the PTI.
 - Public Transport Provisions – Type and frequency of the public transport services available at the PTI.

- Layout Consideration – number of bays, size of bays and platforms for various modes, stacking space, ingress and egress arrangements, column-free areas, crossing facilities¹ and other facilities
- Passenger Information Facilities – Bus route schedules, directional signs, etc.
- Environmental Design – Ventilation, lighting, etc.
- Safety and Security Facilities – CCTV, staffed help booths, etc.
- Passenger Facilities – Toilets, refreshments kiosks, ticketing kiosks/machines, phone, etc.
- Operator Facilities – Lockers, regulator offices, etc.

8.4.4 The extent to which any or all of these requirements will be met will depend upon the predicted usage of the PTI, in terms of passenger departures and arrivals, number of bus movements, and types of buses (size, left-hand drive vehicles with passenger boarding/alighting on right-hand side for cross boundary vehicles, etc.). Each PTI and its location is a unique situation but general guidelines can be set in considering detailed design requirements.

¹ Within the PTI, the safety of pedestrians is of paramount importance, particularly in those situations where bus and pedestrian flows are high and concentrated in a relatively small area. It is therefore desirable wherever possible to segregate these conflicting flows by providing pedestrian routes that are as safe and direct. When designing the pedestrian crossing points, consideration should be given to the possible pedestrian movement within the PTI, such as pedestrian accesses to nearby amenities (e.g. markets, shops, offices, schools, commercial and leisure facilities), bus bays, and pick-up and drop-off points for public light buses and taxis.

8.5 Patronage and Pedestrian Demand

8.5.1 To plan and design a PTI, the patronage for the whole system needs to be assessed. Normally the patronage using a PTI system may comprise the movements as listed in Table 8.5.1.

Table 8.5.1 Passenger/ Pedestrian Movements

Movement	Termed in Transport Planning & Design Manual
Rail to / from adjacent development	Rail-street movements
Rail to / from adjacent PTI for ride in / out passengers	Rail-bus movements (including passengers to / from private feeder modes)
PTI to / from adjacent development	PTI-street movements
Between developments	Street-street movement (walk only pedestrians who do not travel on any mechanized mode)

8.5.2 The number of passengers / pedestrians for each movement has to be identified by different methods as shown in Table 8.5.2.

Table 8.5.2 Method for Estimating Passenger / Pedestrian Movements

Movement	Assessment Method	Remarks
Rail / Street	Public transport forecast model	The worst case in terms of design year and railway network combination should be identified for each PTI. Peak in / out passenger flows will be required.
Rail / PTI	As rail / street	Feeder services for each mode should be identified, including bus, minibus, taxi or private car. For some PTIs such as those at Tseung Kwan O, the requirement for taxi and private cars would not be substantial because of short walking distance from the PTI. If traffic model is not available, the feeder proportion of the existing railway stations with similar travel characteristics could be used.
PTI / Street	Public transport forecast model and general catchment analysis	Normally a public transport model could provide some coarse indication on the pedestrian/bus requirements for a PTI. Additional analysis on the general catchment of the area has to be carried out to estimate the total public transport trips which could be served by the potential PTI.
Street / Street	Pedestrian model	This is an area which is not very well developed in Hong Kong. In general the database for trip characteristics and distribution are not readily available. For some new towns with land use largely residential, town planners and traffic planners would make a general estimate. It would be more complex in Business Districts such as Central or Wan Chai where there will be more walk trips other than those home/work or school.

8.5.3 Once the patronage forecasts are available, passenger / pedestrian volumes can be assigned onto the pedestrian network by the least cost route (shortest, most direct or most convenient route). The pedestrian network and facilities including footbridges and escalators can then be designed accordingly.

- 8.5.4 Given the uncertainty in forecasting street/street or PTI / street patronage, the general practice is to assign some portion of the pedestrian facilities to be used by non-rail passengers (rail / street or rail / PTI) with the remaining portion being used by rail-related pedestrians. While it is not easy to assess the exact number of the non-rail passengers in the actual planning of a PTI, assessment of the requirements for all movements should be provided as far as possible.
- 8.5.5 Normally, the catchment area for walk-in/out bus passengers to/from a PTI is within about 500m of the PTI. This depends on the environment and can increase if good walking environment is provided or vice versa. An example is the long walking distance between Discovery Park and Tsuen Wan MTR station (about 600m) where most passengers use footbridges rather than bus feeder services.
- 8.5.6 The ride-in/out or park and ride catchment can be much bigger. For example, the ride-in/out catchment for Tsuen Wan MTR station/PTI stretches to Tuen Mun, Yuen Long and other parts of northwest NT. For Choi Hung MTR, catchment area covers Sai Kung and Clear Water Bay, through bus feeder services. Regional or district town centres in Tai Po can be served by feeder services to/from Tai Po or Tai Wo Stations.

8.6 Public Transport Provisions

8.6.1 Bus Provisions

- 8.6.1.1 The number of bus bays required for each PTI depends on the number of bus routes terminating and passing at the PTI as well as their frequencies of operation.
- 8.6.1.2 In general the operators prefer one bay per bus route. For traditional parallel bus bay layout, one double width bay or one each for every 5 bays will be required as the minimum for heavy frequency routes with allowance for flexible operation.
- 8.6.1.3 Bus-bus interchange schemes may be introduced at strategic or major PTIs to reduce the number of buses accessing the urban area. Hence, additional bays should be included at the major PTIs at the planning stage if the schemes will be pursued thereat.
- 8.6.1.4 For major PTI with potential provision of cross boundaries services, one to two bays with a passenger platform along both sides of the bays should be provided. The first bay provided should be a triple width (9.5-metre wide) bay to cater for both right-hand driven and left-hand driven coaches. The second bay should be a double width one (7.3-metre wide). The length of each bay should be determined on the basis of the frequency and number of cross boundary routes at the PTI.
- 8.6.1.5 In terms of stacking for buses, the traditional parallel bus bay layout normally (of about 40m length) provides 1 boarding/alighting space and 2 spaces for stacking for each bay. If only one route is assigned to one bay, there will be 2 stacking spaces for each bus route. However, these spaces are not used by buses of other routes even if the spaces are not occupied.
- 8.6.1.6 Given land constraints, it may not be cost effective to lay-over all the buses during off peak hours in the PTI. For the traditional parallel bay layout, the current practice of providing two stacking spaces for each bus route could be adopted. Therefore a bus route, which has two-end terminus, would have a total of 4 stacking spaces.
- 8.6.1.7 For other PTI layouts where stacking areas are separated from boarding/alighting bus bays, the stacking space can be used more efficiently. Again two stacking spaces per bus route at each terminus are suggested.
- 8.6.1.8 Theoretically, there should be a PTI next to each railway station (excluding Light Rail Stations) so that the catchment for the railway station can be increased by feeder services. However, for some stations especially those in business districts, such as Wan Chai, most passengers walk in/out. Rail passengers can also be fed to such stations through passing services of other transport modes.

8.6.2 PLB Provisions

- 8.6.2.1 For low capacity services with very few routes and serving small patronage, such as those for low patronage PLB's only, lay-bys can be used with queuing facilities for passengers and turn-round facilities where necessary.
- 8.6.2.2 The number of bays and passenger platforms will depend on either the number of red PLB's that may accumulate during peak periods or the number of green PLB's assigned to the route. PLB bays should be 3.0m wide between kerbs with a minimum length of 30 metres for 4 PLBs. At least one double-width bay should be provided to facilitate bypassing. A passenger platform with shelter and queue railing should have a minimum width of 2.5m and minimum 2.0m wide without shelter. For locations where red and green PLB bays are required, the bays should be separated. TPDM Volume 9 Chapter 3 also reviews the requirement of PLB's.

8.6.3 Taxis and Private Vehicle Provisions

- 8.6.3.1 Except for stations with long distance travellers, the majority of whom would not carry heavy luggage, it only takes less than 1 minute on average for a taxi (or private car) to set down a passenger, including

the time for payment and change. Boarding is much quicker and about 0.5 minute per vehicle could be assumed. With the anticipated number of passengers using taxi or private mode, the number of bays required could be estimated.

- 8.6.3.2 The number and length of the taxi stand will depend on the taxi type, taxi demand and location of PTI. Taxi types include Red, Green and Lantau taxi's. For PTIs with mixed operation of different types of taxis, each taxi type should have their own taxi stand. To permit over-taking activities, at least one double width taxi bay should be provided for each type of taxi operated. Taxi stands' should be 3.0m in width from the kerb with a minimum length for 3 taxis. Depending on the taxi demand, double-width bay should be provided to facilitate multiple alighting/boarding area. The length of taxi stand should also accommodate some stacking requirements of off-peak hours when turn over is low.
- 8.6.3.3 The width of platform and queuing arrangement should cater for passenger with special needs.
- 8.6.3.4 For most of the MTR stations except those terminal stations, the use of private cars or taxis (termed as private mode hereafter) as feeders is fairly low. Nevertheless, to encourage the use of railway, "kiss and ride" facilities and taxi stands should be provided unless picking-up or dropping-off can be done in side streets nearby.
- 8.6.3.5 Most of the railway stations in Hong Kong have associated station development. General pick-up or set-down points for vehicles would be provided as part of the development. If this facility is conveniently linked to a railway station, private feeder modes to the station can make use of the facilities for station development if they are open to public use. However, most developers of station developments prefer to have the general pick-up and drop-off points to serve their developments only for the ease of management and control. Hence, separate pick-up and drop-off points should be considered.

8.6.4 Non-road based public transport provisions

- 8.6.4.1 LRT, MTR, East Rail and ferry services at a PTI operate independently and within their own boundaries. Their interface with the PTI area can be taken as the point of entry and exit to/from their control area. The number of bays to be provided at the PTIs for the road-based terminating services, e.g. bus and green minibus etc, to accommodate the interchanging passengers from these non-road based high capacity services should be fully taken into account at the planning stage.

8.6.5 Bicycle Provisions

- 8.6.5.1 For East Rail stations in northeast NT, about 1% of passengers use bicycles to access a station. This number can be applied to West Rail in northwest NT because similar travel pattern would be expected, although it can be lower because of the presence of LRT. With the forecast rail patronage, the requirement for bicycle parking spaces can be estimated. Nevertheless, these estimates would need to be critically examined having regard to each station and the availability of cycle track connecting the PTI.
- 8.6.5.2 However, some management procedures would have to be derived to control the use of bicycle parking spaces at the railway station in order to avoid the bicycles being parked at the site permanently.

8.7 Layout Considerations

- 8.7.1 Most bus services using an interchange are likely to terminate there, though some “through” services may call at the interchange. The facility should be capable of handling the required numbers of vehicles and passengers safely and efficiently at minimum cost. Taking into account that some PTIs may be used by more than one public transport operator, the layout design of the PTIs especially for provision of operators’ facilities would need to be looked into as early as possible at the planning stage.
- 8.7.2 Diagram 8.7.1 illustrates the main types of bus loading and unloading bays. Buses should be able to enter and leave the interchange with minimum delay and without major detours from a direct route, especially in the case of through services where through passengers may be inconvenienced by long detours. Streams of arriving and departing buses would unlikely to have conflicting movement within a bus terminus. If taxi, kiss & ride or park & ride facilities are provided, there should be no conflict between vehicles using these facilities and buses.
- 8.7.3 Diagram 8.7.2 shows a traditional PTI layout with parallel platforms and bus bays in Hong Kong. It is believed that the peripheral bay layout is safer and more convenient than the traditional parallel bay layout.
- 8.7.4 For the design of the appropriate signs and markings for PTIs, reference can be made to Volume 3 of the TPDM.
- 8.7.5 Layout design includes: number and size of bays and platforms for various modes, stacking space, swept path, space for operators’ and other PTI facilities, ingress/egress arrangement, headroom, column-free areas, crossing facilities, pedestrian walkway, stair, lift and escalator provision etc.
- 8.7.6 To facilitate bus captains accessing the bus stacking areas, bus loading bays and staff ancillary facilities, crossing facilities should be included as appropriate in the planning stage of bus termini/PTIs.
- 8.7.7 The design of all new interchanges should cater for the manoeuvring of buses, taking into account their maximum dimensions, that will operate in the interchange.
- 8.7.8 For PTIs to accommodate public light buses, taxis, private vehicles, and residents’ services, their terminal layout should follow the design provided in Volume 9 Chapters 2 and 3 of the TPDM.
- 8.7.9 The internal road layout and headroom clearance of PTIs should be in accordance with the standards given in Volumes 2, 6 and 9 of the TPDM. In the design of the layout, special attention should be given to the following:
- Parking and loading/alighting arrangements;
 - Segregation of bus and passenger movements;
 - Segregation of different modes including the ingress and egress points;
 - Stacking areas for the public transport vehicles; and
 - Pedestrian routes.
- 8.7.10 All new PTIs should include column-free areas in the preliminary design drawings according to Departmental Circular No. 4/2020. Column-free areas refer to areas that should not be occupied by columns, walls, escalators, staircases or any other associated installations, such as ventilation ducts and louvers, column claddings and barrier fences for column protection, to achieve the required sightline for drivers and pedestrians, horizontal clearances and areas for passenger circulation and queuing. The Column-free areas should be indicated in the preliminary design drawings from the early stages of the projects, which shall be used to control the subsequent detailed design and construction of the PTIs.
- 8.7.11 The transport interchange should preferably be designed with the exits of one mode is close to the entrances of other modes such that transfers are direct and require minimal time. Extensive use of

escalators and people movers is desirable.

DIAGRAM 8.7.1: TYPES OF LOADING AND UNLOADING BUS BAYS AT PUBLIC TRANSPORT INTERCHANGE

SINGLE-BUS,DRIVE-THROUGH,LINEAR STANDS

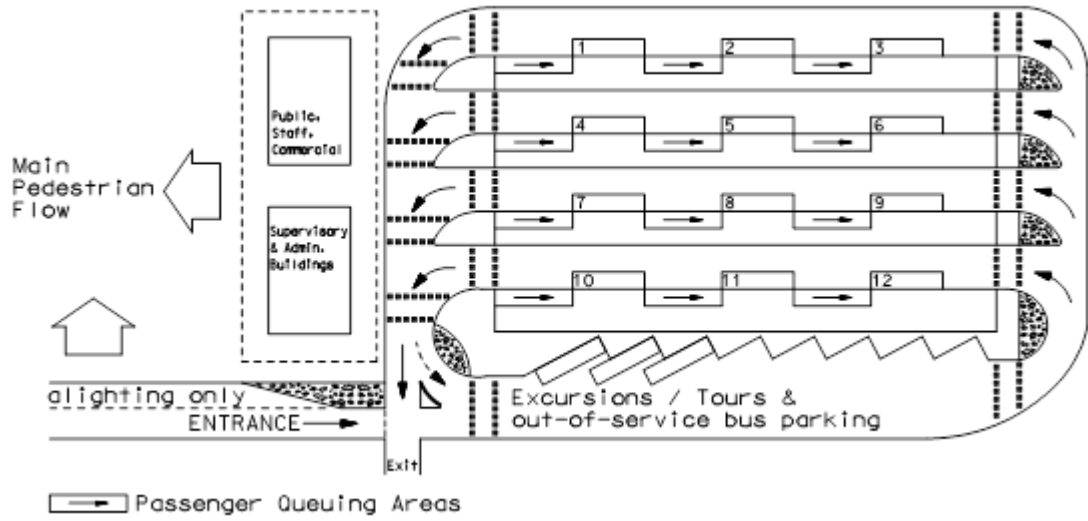

SINGLE-BUS,DRIVE-THROUGH,SHALLOW-SAWTOOTH STANDS

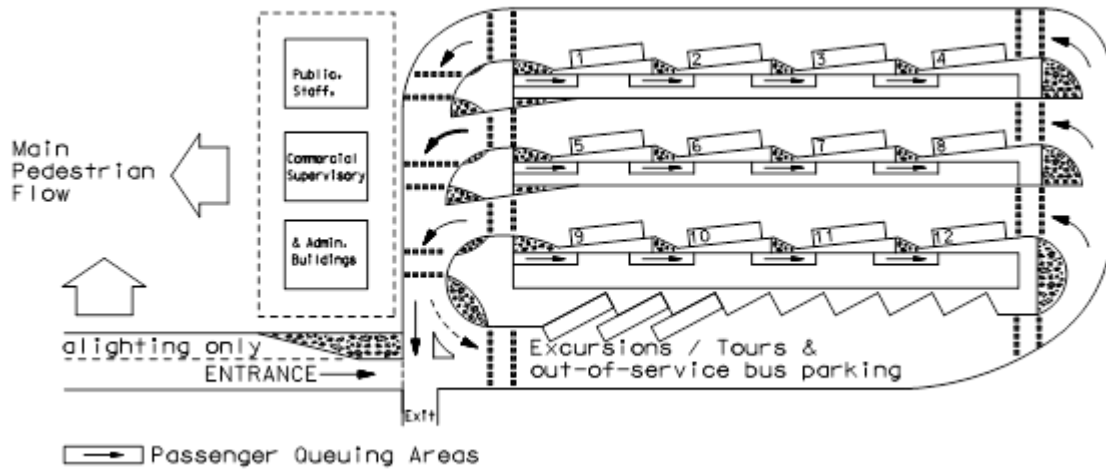

SINGLE-BUS,90 DEGREE,REVERSING STANDS

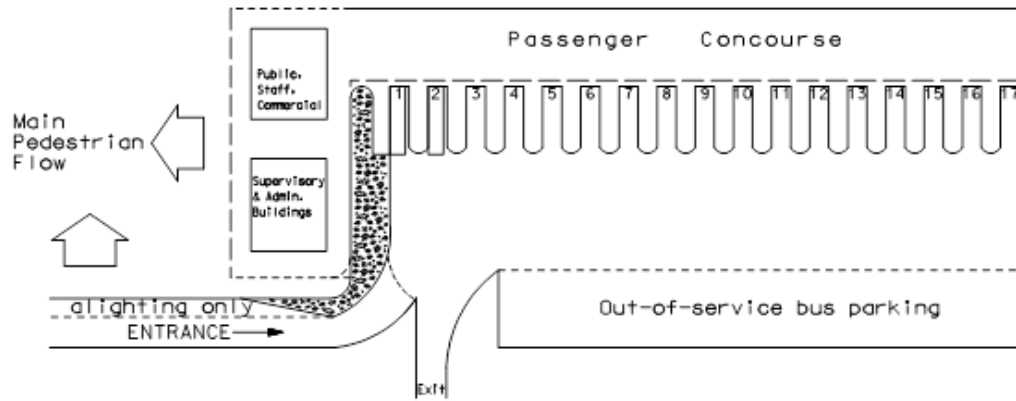
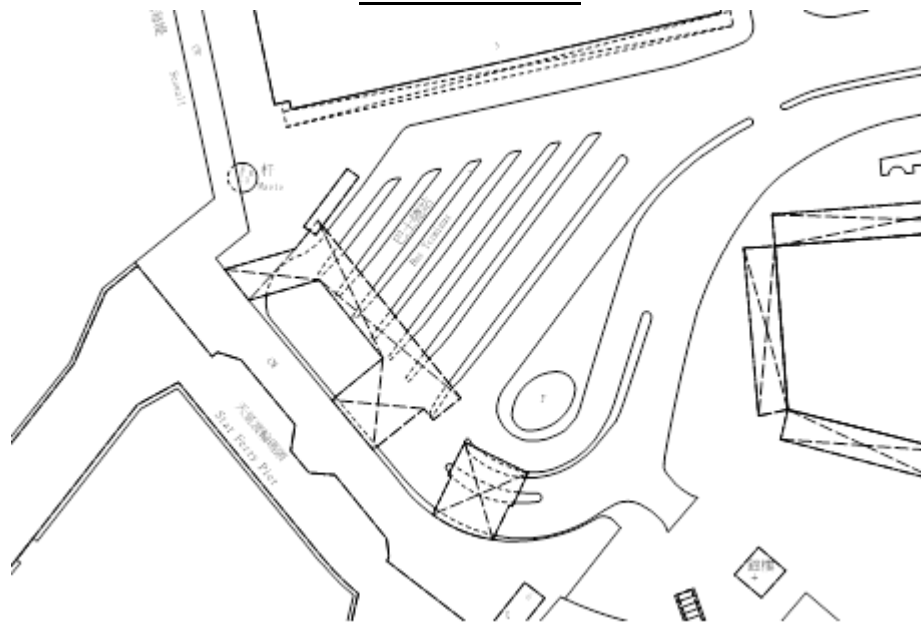

DIAGRAM 8.7.2: TRADITIONAL PARALLEL BAYS FOR PUBLIC TRANSPORT INTERCHANGE



- 8.7.12 A summary of current types of PTI layout with advantages and disadvantages is listed in Table 8.7.1.
- 8.7.13 Currently, it is generally accepted that single bus saw-tooth bays are more efficient in terms of overall use of space. The concept of saw-tooth is to guide buses to stop at the location that does not interfere with other buses, and each bus can get in and out any time without being blocked by others.
- 8.7.14 Diagram 8.7.1 shows an island with a saw-tooth bus platform layout. All boarding and alighting will be on the island. Bus layover could be arranged at the periphery of the PTI. Air conditioning and other associated facilities could be planned on the island. Also, it is possible to have more than one group of queuing area per saw tooth platform, which can be easily arranged by railing within the island. Different modes can be assigned to different saw-tooth platforms.
- 8.7.15 Diagram 8.7.1 represents a very efficient PTI that each platform could be used efficiently with minimum idle time. The apparent disadvantages would be the lack of physical segregation in the driveway and in the layover area that could impose difficulties on different operators.

Table 8.7.1 Comparison of PTI Types

Type of PTI	Advantages	Disadvantages
On street (without lay-by)	<ul style="list-style-type: none"> • Easy for bus manoeuvring in and out 	<ul style="list-style-type: none"> • Lack of proper space for passengers to queue along the footway. Areas with proper shelters and railings would reduce the effective footway width. • Road and footway capacity reduced • No air conditioning at passenger queuing area
Traditional parallel bays	<ul style="list-style-type: none"> • One route (or maximum two) per bay is a very clear arrangement to passengers and operators 	<ul style="list-style-type: none"> • Inefficient use of stacking spaces • Unless with stairs or escalators to second level, passengers have to get across the bus bay or driveway of the PTI • No air conditioning at passenger queuing area
Sawtooth bus bay, central stacking	<p>(An example is the PTI next to Tsing Yi Station)</p> <ul style="list-style-type: none"> • Efficient use of stacking spaces • Passengers do not have to get across bus traffic • Possible to provide air conditioning for queuing passengers • Facilitate bus-bus interchange • Buses park at precise locations, hence not obstructing other buses 	<ul style="list-style-type: none"> • A big site, probably with more than one ingress and one egress, needed • In general, longer walking distance for passengers • Very wide column spacing for bus maneuvering needed
Central island passenger platform	<p>(An example is the PTI underneath Shatin New Town Plaza)</p> <ul style="list-style-type: none"> • Efficient use of platform space because passengers queuing for more than one bus routes could be arranged for one island platform • Possible to provide air-conditioning for queuing passengers • Possible to provide passenger facilities such as kiosk or information desk in the island platform. 	<ul style="list-style-type: none"> • A big site, probably with more than one ingress and one egress, needed • Segregated pedestrian walkway need to be provided to link up the central island with the station or development

8.7.16 Different concepts for PTI layout have to be considered on its own merits, taking into account the location, size, nature and the surrounding environment of an interchange. The sawtooth type layout would provide the best environment to passengers and the most efficient use of bus bays and layover facilities, particularly if operators are prepared to run up to two but less frequent routes per saw-tooth bay.

8.7.17 It is recommended that for new PTIs, it should adopt the peripheral saw-tooth layout unless site configurations or constraints render such design unfeasible. In the latter situation, central island type saw-tooth design with segregated pedestrian access to the island should be pursued. The parallel platform type design should only be considered when both sawtooth type designs are not feasible. It should be noted that for the peripheral layout and central island type layout, a straight-kerb without saw-tooth can also be acceptable. The general guidelines to determine the types of PTI to be adopted is shown in Table 8.7.2.

Table 8.7.2 Guidelines on PTI Designs

Type of PTI	Applicable to Sites
Traditional parallel bays	A small site with only limited number of bays (say 3-4)
Peripheral sawtooth bus bay, central stacking	(a) A site of minimum breadth 60m. Otherwise there will not be enough space for buses to manoeuvre. (b) Major pedestrian generator would be at the same level. An example is Tsing Yi where both MTR passengers and other passengers would be at podium/footbridge level. Another example is Mei Foo. (c) Any development above could be supported by large column spacing
Central island passenger platform	(a) A site of minimum breadth 60m. (b) Major pedestrian generator at a different level. An example is Tsuen Wan where very few passengers access the PTI at the same level.

- 8.7.18 As stated in TPDM Volume 9 Chapter 2, problems may arise in developing a PTI at the ground floor of building. An optimum grid system of the column structure should be derived to satisfy the requirements of a PTI and the structural requirements of the building.
- 8.7.19 Diagrams 8.7.3 to 8.7.5 show design examples for traditional parallel bay, peripheral sawtooth and central island sawtooth PTI layouts.
- 8.7.20 For large scale interchanges such as Tsuen Wan Station or Tsing Yi Station PTIs, it is preferable to have the PTI integrated to the concourse of the railway station.
- 8.7.21 In terms of passenger queuing area on each bus platform, TPDM Volume 9 Chapter 2, Diagrams 2.6.3.2 and 2.6.3.3 have been reviewed and are considered in general acceptable. The railing spacing varies between 0.6m and about 0.9m. Operators would prefer to have 0.9m to allow people bypassing people waiting for the next bus. This is in general supported at least for the first row of passenger queuing area.
- 8.7.22 Another reason for supporting 0.9m railing spacing is to provide a better level of service for queuing passengers. For more efficient use of space, the 0.9m spacing could be considered with local narrowing to 0.6m at column positions. Openings at queue railings particularly on kerb side, for people bypassing waiting people, are not supported because it could cause confusion and safety problems to passengers.
- 8.7.23 Pedestrian crossing points within the boarding/alighting bay of the PTI should be located at rear end of the boarding/alighting platforms. Such an arrangement would enable pedestrians/passengers to see the incoming and leaving vehicles. In general, pedestrian crossing points located at the front end of the boarding/alighting platforms may have poor visibility for pedestrians and drivers since their sightline would be obstructed by stopped vehicles. When designing the pedestrian crossing points, consideration should be given to the possible pedestrian movement within the PTI, such as pedestrian accesses to nearby amenities (e.g. markets, shops, offices, schools, commercial and leisure facilities), bus bays, and pick-up and drop-off points for public light buses and taxis.
- 8.7.24 For design of the lighting system of PTI, luminaries should not be mounted right above the parking areas to reduce lighting being blocked by vehicles. References can be made to the Public Lighting Design Manual by Highways Department.
- 8.7.25 Similar to bus termini, painting of alternate black and white striped marking at kerbs and alternate black and yellow striped marking at barrier could be considered to improve the visibility and contrast of kerbs and barriers inside PTI. Reference should be made to para. 2.7.4.9 in Chapter 2 of this

Volume.

8.7.26

A summary of the proposed guidelines for designing the layout of PTIs is shown in Table 8.7.3.

DIAGRAM 8.7.3 TRADITIONAL PARALLEL BAY LAYOUT FOR PUBLIC TRANSPORT INTERCHANGE

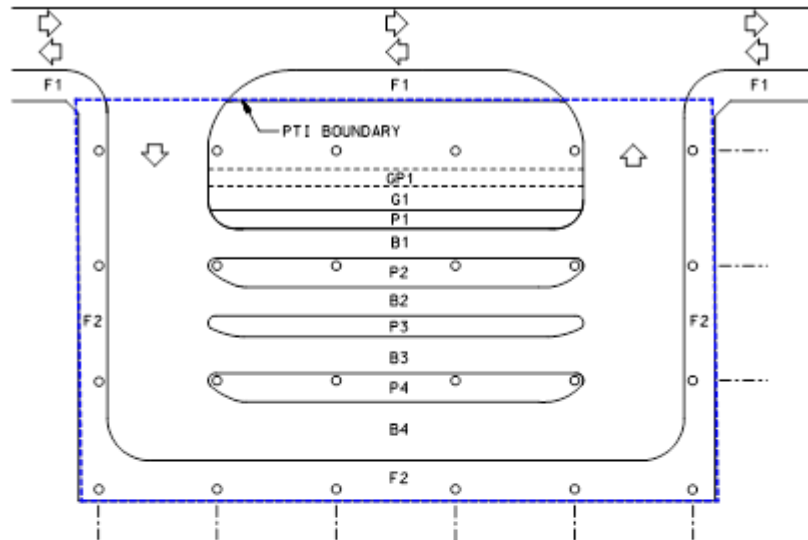

NOTES :

- (1) ASSUME 1m DIAMETER COLUMNS 0.5m CLEARANCE TO COLUMN.
- (2) EFFECTIVE QUEUEING WIDTH FOR P1= P2= P4=(0.6m + 0.9m) RAILING + 0.6m CLEARANCE = 2.1m FOR 2 ROWS OF QUEUEING PASSENGERS.
- (3) P3 = 0.5m CLEARANCE (NON-BOARDING SIDE) + (0.6m + 0.9m) RAILING + 0.6m CLEARANCE (BOARDING SIDE) = 2.6m FOR 2 ROWS OF QUEUEING PASSENGERS.
- (4) UNDER SITE CONSTRAINTS, EFFECTIVE QUEUEING WIDTH P2 COULD BE REDUCED TO 0.6m RAILING + 0.6m CLEARANCE = 1.2m FOR LOW DEMAND BUS ROUTES.
- (5) UNDER SITE CONSTRAINTS, WIDTH P3 COULD BE REDUCED TO 0.5m CLEARANCE + 0.9m RAILING + 0.6m CLEARANCE = 2m.
- (6) POSSIBLE TO HAVE GMB PLATFORM AND BAY (GP1, G1) WHICH ARE CLOSER TO ENTERANCE/EXIT, BUT WIDTH P1 HAS TO BE ADJUSTED TO 2.6m TO ALLOW FOR 0.5m CLEARANCE ON THE NON-BOARDING SIDE.
- (7) WIDTH OF PUBLIC FOOTPATH (F1) VARIES.
- (8) WIDTH OF PERIPHERAL WALKWAY (F2) TO BE 1.8m TO 2.7m CLEAR MINIMUM BUT ADDITIONAL WIDTH IS REQUIRED FOR SHOP FRONTAGE.
- (9) WHEN NECESSARY, THE NUMBER OF ROWS FOR QUEUEING PASSENGERS COULD BE REDUCED FROM 2 TO 1 OR THE WIDTH OF RAILING FOR THE QUEUE FROM 0.9m TO 0.6m AT BOTH ENDS TO ALLOW FOR THE SPLAY.

DIAGRAM 8.7.4: SAMPLE LAYOUT FOR SAWTOOTH BUS BAY AND PLATFORM

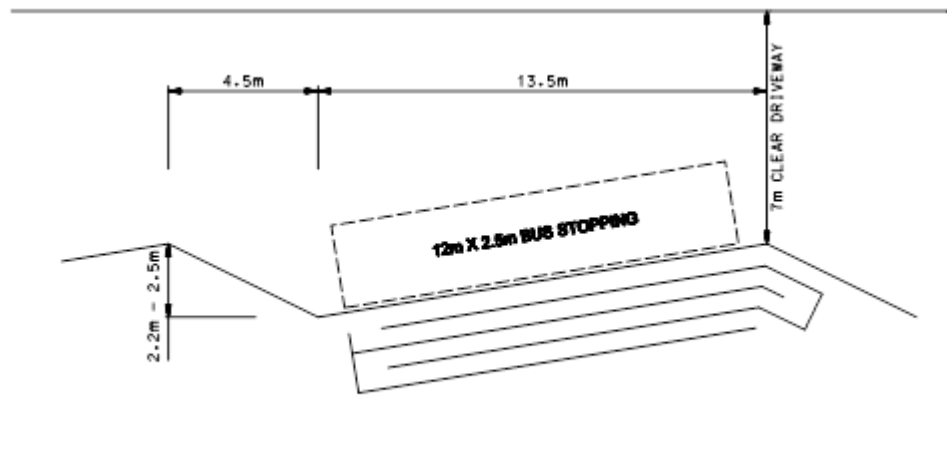
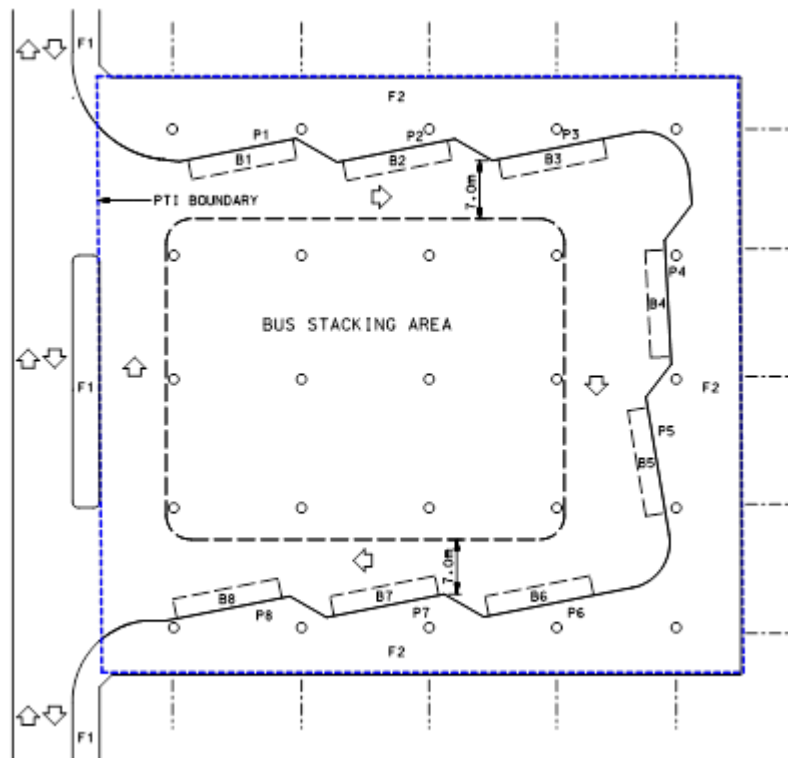
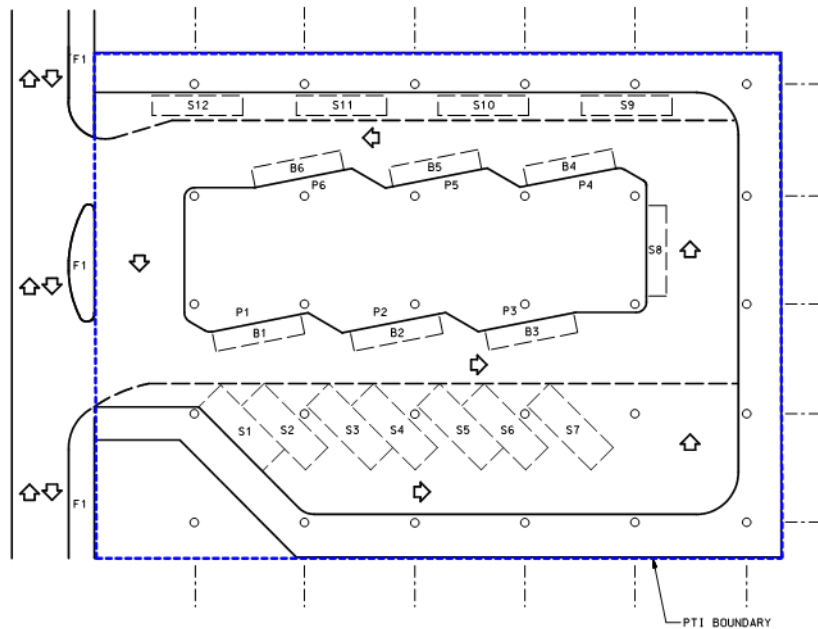

DIAGRAM 8.7.5: PERIPHERAL AND CENTRAL ISLAND LAYOUT FOR PUBLIC TRANSPORT INTERCHANGE

PERIPHERAL PTI LAYOUT EXAMPLE



CENTRAL ISLAND PTI LAYOUT EXAMPLE



NOTES :

- (1) WIDTH OF PUBLIC FOOTPATH (F1) VARIES.
- (2) WIDTH OF PERIPHERAL WALKWAY (F2) TO BE 1.8m TO 2.7m CLEAR MINIMUM BUT ADDITIONAL WIDTH REQUIRED FOR SHOP FRONTAGE.
- (3) BAY B4 OF PERIPHERAL PTI LAYOUT SET BACK TO ALLOW FOR BUS TURNING OUT OF BAY B5.

Table 8.7.3 Guidelines for Layout Design of PTI Serving Railway Stations

Items	Proposed Design Guidelines/ Standard	Remarks
Bus bays (traditional straight design)	For traditional straight parallel bus bays, 1 per bus route, 3.5m width each; minimum one double bay (7.3m) or one for every 5 bays.	According to passenger demand for buses, including those for bus to bus interchange.
Bus platform (traditional design)	For traditional straight parallel bus platforms, 1 per bus route; 0.9m preferred railing spacing for passenger queuing; 38m minimum length excluding splays at both ends & pedestrian crossing; railing from kerb should be 0.6m clear for alighting passengers. The boarding point at the platform should be raised to around 180mm.	Dimensions from TPDM, Volume 9 Chapter 2, Diagrams 2.6.3.2 to 2.6.3.3 in general acceptable for roadside bus shelters. The first row of passenger queuing area should be designed with 0.9m railing spacing to allow for people bypassing people waiting for next bus, and for a better level of service. Reduction of queuing railing to 0.6m will be subject to Transport Department's discretion.
Two way bus platforms (2-sided, sawtooth or straight)	Passenger queuing area on each side and 2m minimum for central distribution walkway. The boarding point at the platform should be raised to around 180mm.	Dimension / layout from TPDM, Volume 9, Chapter 2, diagrams 2..7.14.2(B) and 2.7.14.4(B) in general in order except for the railing spacing. Queue railing spacing and clearance refer to "Bus platform (traditional design)" above.
Bus stacking spaces	Minimum 2 spaces per route.	Excluding the space for active loading.
Taxi bays	8-10m length for each taxis, 6m width or with sufficient width for bypassing/exiting. Taxi queuing length provision depends on demand for taxis and the design should ensure that the taxi queue should not affect operation of other vehicles in the PTI.	Straight kerb layout could be used for taxi bays but sawtooth bays have to be considered if more than 3 taxi bays for simultaneous loading are required.
General pick up and drop-off bay	Minimum one number, each 40m length, 7.3m width and 6.0m headroom.	This is the design guideline for major PTIs attached to main Railway Station. The purpose is to allow for all non-franchised modes to pick-up and drop-off passengers. This could also be used by contingency buses during railway operation incidents. At major PTIs 1-2 bus bay(s) should be provided for cross boundary passengers
Column-free areas	Designation of column-free areas near (a) vehicular entrances and exits of PTIs, (b) vehicle-vehicle conflict points, (c) pedestrian-vehicle conflict points, (d) horizontal clearances, (e) passenger queuing areas and (f) passenger circulation areas.	Dimension / layout refer to Departmental Circular No. 4/2020

Bicycle park (in northwest NT for Tuen Ma Line Stations and in northeast NT for East Rail Line Stations)	1% of the forecast patronage of railway station between 7:00am and 10:00am.	Assuming most of the home based work trips or morning school trips take place between 7:00-10:00am. Provision subject to station locational characteristics.
Pedestrian walkway or footbridge or subway	Two way flow of 33 to 49 persons/metre/minute or level of service "C".	In the view of high pedestrian flow to most of the railway stations in the urban areas, it may be necessary to achieve level D of service i.e. (1.39 sq.m or 49 to 66 persons/metre/minutes). 1.0m edge effect each side should be deducted for footbridge/subway with shop frontage, higher value for shop frontage with high pedestrian activities. No deduction for no frontage notwithstanding TPDM, Volume 2, Chapter 3, Section 3.4.11.
Stairs / ramp steeper than 1:12	Two way flow of 23 to 35 persons/metre/min. Essential for change of level.	Assumed as 70% of walkway capacity as TPDM, Volume 2, Chapter 3, Section 3.4.11
Escalators	One way flow of 100 persons/metres/min when there is change of level.	About 80% of MTRC escalator design capacity.
Lifts	At least one required for each change of level unless escalators are provided or similar facilities are available in the vicinity of the PTI.	Should fulfil Architectural and Engineering & Mechanical standards, with ramp access.
Headroom for PTI	6m clear as preferred minimum.	Although 5.1m could satisfy the highway minimum as TPDM, Volume 2, Chapter 3, Table 3.5.1.1, 6m clear should be provided as far as possible to facilitate good ventilation and visual acceptance.
People movers		To be provided when the interchange involve long distance.
Location of PTI	Should be integrated to the same level of the railway station concourse as far as possible.	This would depend on site constraint, design of the railway station and the associated development.
Swept path	As Section 2.3.2 - 2.3.3 of TPDM, Volume 9, Chapter 2.	The current standard should be maintained.

<p>Ingress and egress arrangement</p>	<p>(a) Section 2.9.7 of TPD, Volume 9, Chapter 2 is still generally applicable.</p> <p>(b) Separate accesses and egresses should be designed for franchised and non-franchised services unless the site of the PTI is too small and in such circumstances, the facilities for non-franchised services may be considered in another site.</p> <p>(c) If under the site constraints only a single access could be provided for the PTI, the design for loading bays for taxis or other vehicles should ensure tailing back from such would not affect franchised bus operation.</p> <p>(d) Separate access is required for the bicycle park though it could be integrated with the footpath.</p>	
<p>Crossing facilities</p>	<p>(a) For central island type platform where the driveway is wide, grade separated pedestrian facilities from the platform is essential.</p> <p>(b) For parallel bay platform, grade-separated facilities is also preferred. If this is not feasible, clearly designated crossing facilities must exist.</p> <p>(c) Crossing facilities should be provided for both pedestrians and bus captains. When designing the pedestrian crossing points, consideration should be given to the possible pedestrian movement within the PTI. To facilitate bus captains accessing the bus stacking areas, bus loading bays and staff ancillary facilities, crossing facilities should also be provided as appropriate.</p>	<p>Drop kerbs for disabled persons should be provided.</p>

8.8 Passenger Information Facilities

- 8.8.1 Passengers may be either regular travellers or “first time travellers”. Indeed in the case of new railways, all users will start off as “first-time” users.
- 8.8.2 Ideally the layout of the interchange should be readily comprehensible, though this often not possible when the railway is underground. Hence first time travellers to a particular location will be especially dependent on signs, information displays and staff to accomplish their journey in a rapid and stress-free manner. For instance at all points at which interchanging passengers arrive (or enter from the street), there should be interchange location diagrams showing where connecting services and other facilities are to be found.
- 8.8.3 Walking routes between public transport modes should be clearly marked on both the facility maps themselves and on the actual walking routes connecting the different parts of the interchange. Each boarding point should include details of the routes and timetables of the services serving that stop. Information should be provided either by conventional printed information and/or signing. Location of the displayed information should be obvious. Adequate standing space should be provided for viewing complex information signs such that patrons viewing information do not create a bottleneck situation to pedestrian movements in the vicinity. To avoid causing confusion to passengers, coordination of signage systems is also required between the developments of the rail operators and the Government’ property in the vicinity of PTIs.
- 8.8.4 However, there may also be a case for the provision of on-line real time passenger information systems. This is fairly straightforward to provide for rail systems. KCRC and MTRC are providing “Countdown Indicators” on their station platforms showing the destinations and number of minutes to the arrival of the next one, two or three trains.
- 8.8.5 It is less straightforward to provide on-line information on bus systems, as this usually requires an Automatic Vehicle Location system. However at termini, information displays showing expected departure time of the next one or two buses on each route can be operated by the Timekeepers (e.g. this is done at major interchanges in Singapore, and by KMB at its Star Ferry Bus terminus).
- 8.8.6 When there is major disruption of bus or train services, there are special information needs. Where formal contingency plans have been made for the operation of replacement bus services in the event of disruption to the rail service, it would be worth incorporating details in the permanent information displays in the interchange. Also at major bus-rail interchanges, it would be appropriate to include public address and variable message signs in the bus interchange driven from the railway control room that can inform passengers of disruption to the rail services and the alternative arrangements.
- 8.8.7 At large interchanges, the provision of a staffed information desk should be considered. In Hong Kong, “Travel Centres” at interchanges can also be used not only to provide information but also to sell and add value to contactless smartcards.
- 8.8.8 The passenger information facilities to be provided in PTIs are as follows:

Table 8.8.8 Passenger Information Facilities to be provided in PTIs

Facilities		Remark
Direction signs and location diagram	E	Direction signs should be erected at all entrances/exits/passageway to guide passengers about the desire line to the railway station and the PTI, and the services at the PTI.
Passenger information panel	E	Display location map and overall layout map of the railway station and PTI, and summary of bus, minibus services.
Passenger information desk/centre	D	For provision of <ul style="list-style-type: none"> • line maps • fare information • transfer information • timetable • enquiry • complaint services
Electronic display panels	D	Provide real time information including departure time of the service/routes, and information during incidents.
Bus terminus name panel	E	Facilitate easy identification of the terminus by passengers.
Interactive bus stop	D	Provide more comprehensive route information to serve passengers, including those who are visually impaired.
Large face clocksp	E	To be provided at conspicuous place
On-line information kiosk	D	Provide transport service and transfer information. Management and updating responsibilities to be investigated further.
Public announcement system	D	Provide special information to passengers especially during emergency arrangements (may be mounted up by the railway or bus operator)

Notes: E : Essential, D : Desirable

8.9 Environmental Design

8.9.1 The design of a ventilation system will affect air quality within a PTI. The air quality within a covered PTI should meet the standard stipulated in EPD's Practice Note for which provides the following guidelines:

Table 8.9.1 Air Quality Guidelines for covered PTI

Air Pollutants	Maximum Concentration* Not to Be Exceeded	
	1-Hour Average (mg/cu. m.)	5-Minutes Average (mg/cu. m.)
Carbon Monoxide	30,000	115,000
Sulphur Dioxide	800	1,000
Nitrogen dioxide	300	1,800

*Expressed at the reference condition of 25oC and 101.325kPa (one atmosphere)

8.9.2 The results of some focus group researches conducted in Hong Kong show that most passengers will welcome improvement in the ventilation of PTIs.

8.9.3 To protect waiting passengers from exhaust emissions and heat, it is recommended that new PTIs should as far as applicable to have air-conditioned waiting areas. The criteria for provision of air-conditioned waiting area at PTIs includes the following:

- The layout should either be central stacking with loading and unloading berths at the periphery of the PTI or central island passenger platform with all boarding and alighting activities at the island and stacking of buses at the periphery of the PTI.
- Priority to be given to PTIs located at
 - areas of high background pollution like Central, Admiralty, Wan Chai, Causeway Bay, Tsim Sha Tsui, Mong Kok, Kwai Chung, Tsuen Wan and Kwun Tong;
 - at railway stations to encourage use of railway;
 - at bus-to-bus interchanges to encourage interchange between buses;
 - at tourist spots e.g. Disney Park, Tsim Sha Tsui, the Peak and Stanley to improve the image of the public transport facilities in the city;
 - at housing estates where utilization is high; and
 - at PTIs and BBIs where the design of which do not allow free air flow.
- Priority should also be accorded to PTIs to integrate with air-conditioned surroundings like railway concourse and big shopping arcade.
- If provided, the air-conditioned waiting area should be used by passengers on all PT modes using the PTI unless site constraints render this not feasible.

8.9.4 Under the current requirement stipulated by Highways Department, the illumination for the PTI should be in the range of 120 – 150 LUX at ground level. Highways Department advises that for PTI, linked with railway stations, the illuminance should be on the high side of this range to harmonize the environment. The design of the lighting system shall comply with the Public Lighting Design Manual by Highways Department.

8.10 Safety and Security Facilities

- 8.10.1 In terms of safety, a particular issue relates to the crossing of the “tracks”. On most urban railways (including MTRC and KCRC), it is totally prohibited for passengers to cross the tracks on the level; they have to use a bridge or subway. On most light rail systems, including the Tuen Mun LRT and Hong Kong Tramways, at-grade crossing of the tracks is the norm.
- 8.10.2 It is much less desirable that passengers interchanging between rail and bus should be required to cross public roads at-grade or that they should be required to use open (unsheltered) walking routes.
- 8.10.3 Personal security at night is becoming a concern of public transport users. Personal security (and the equally important perception of security) can be enhanced by measures such as:
- high levels of lighting;
 - good standards of cleaning and maintenance (especially to repair vandalism and remove graffiti);
 - designing out dark and hidden corners;
 - the presence of staff, and
 - the use of closed circuit television cameras (CCTV).
- 8.10.4 Table 8.10.4 shows the proposed facilities and equipment within a PTI to enhance safety and security of passenger/operators. Some of them can be provided as part of the railway station while others can be provided at a PTI.

Table 8.10.4 Proposed Safety & Security Installations in PTI

Facilities	PTI		Remarks
	NRS ⁽¹⁾	RS ⁽²⁾	
Guards	D	D	security control provisions
CCTV	E	E	CCTV cameras would be essential at PTI especially during emergency. Railway operators have design guidelines for CCTV cameras.
Fire service equipment	E	E	Should meet Fire Services Department's requirement

Note:

(1) - NRS: PTI without railway station

(2) - RS: PTI with railway station

E: Essential, D: Desirable

8.11 Passenger Facility Requirements

- 8.11.1 Knowledge of the interacting passenger movements is important in order to establish threshold capacities of pedestrian routes. Pedestrian circulation at interchanges is simply another form of traffic management. One-way routing of passengers removes conflicts and speeds up the flow. Separation of arrivals and departures is important at interchanges.
- 8.11.2 An important element in the attractiveness and acceptability of a journey is the quality of the interchange facility. Making an interchange requires a passenger to spend time in walking between stops or platforms and waiting for another service. It is therefore an important aim to minimize the time and effort involved in interchanging and to make the time spent as congenial as possible.
- 8.11.3 In terms of minimizing walking time and effort, possible approaches include:
- layouts that minimize walking distances between various services and modes;
 - provision of people movers where long walks cannot be avoided;
 - provision of lifts and escalators to overcome differences in levels;
 - provision of a congenial and safe walking environment, e.g. attractive surroundings, sufficient capacity to avoid excessive crowding or delays, good lighting, good weather protection (covered walkway, air-con if indoors), minimization of pedestrian-vehicular conflicts, and ensuring high levels of personal security.
- 8.11.4 This usually requires a PTI to be designed as an integral part of the rail station. In particular, the alignment, vertical profile and location of a railway station should not be planned as a free-standing system with bus terminals then provided on an available adjoining site. Such an approach must be avoided if walking time is to be minimised. For PTI which is to be integrated with a rail station, it is desirable to be at the same level with the station concourse.
- 8.11.5 In the case that the exit of one mode is far apart from the entrance of other modes, people movers or passenger conveyor belt should be considered, particularly if there is a long walking distance. In general there is no particular standard for maximum walking distance but it is desirable to be within 500 m if a comfortable environment is provided. Otherwise a passenger conveyor belt is required.
- 8.11.6 A comprehensive system of pedestrian link with suitable pedestrian crossing points shall be provided to facilitate pedestrian circulation. Passenger platforms, footways and drop kerbs shall be constructed as specified in the technical schedule. Safety and protection measures such as railings, kerbs and column guards shall be provided in accordance with Highways Department's standards as required by relevant authorities including the Arch SD. Non-slip floor finishes shall be provided throughout. The provision of doors should be avoided as far as practicable while pedestrian links should be segregated from traffic as much as possible.
- 8.11.7 For PTIs which are located outdoor and subject to inclement weather, consideration should be given to the provision of covered walkways. Where the pedestrian movements are high, it is desirable for the covered walkway to be integrated with such as the entrances of the railway station so as to maintain a weather-protected link. Diagram 8.11.7 illustrates conceptual proposals for the provision of cover between the entrance of a railway station and the footway leading to a PTI to protect passengers against inclement weather.
- 8.11.8 Ideally, all essential services should be provided on one level, (i.e. the ground floor of an interchange), and there should be no changes of level within floors. In practice, this is not always feasible. Where there are stairs, a complementary ramped route should be provided to facilitate the movement of the wheelchair users and passengers with special needs. Tubular handrails should be provided on both

sides of a flight of steps. Escalators should be used if the pedestrian volume so warrants. The design standards are set out in Section 3.7 of Volume 2 of the TPDM. In case a ramp cannot be provided for reasons such as site constraints, consideration should be given for the provision of a passenger lift to facilitate the movements of passengers with special needs.

8.11.9

In general, ramps, lifts, tactile tiles, stanchions, pathways with high color, audible signal at entrance/exit/map, braille maps, etc should be provided to cater for the needs of the disabled.

DIAGRAM 8.11.7: CONCEPTUAL PROPOSALS FOR A WEATHER PROTECTED PEDESTRIAN LINK

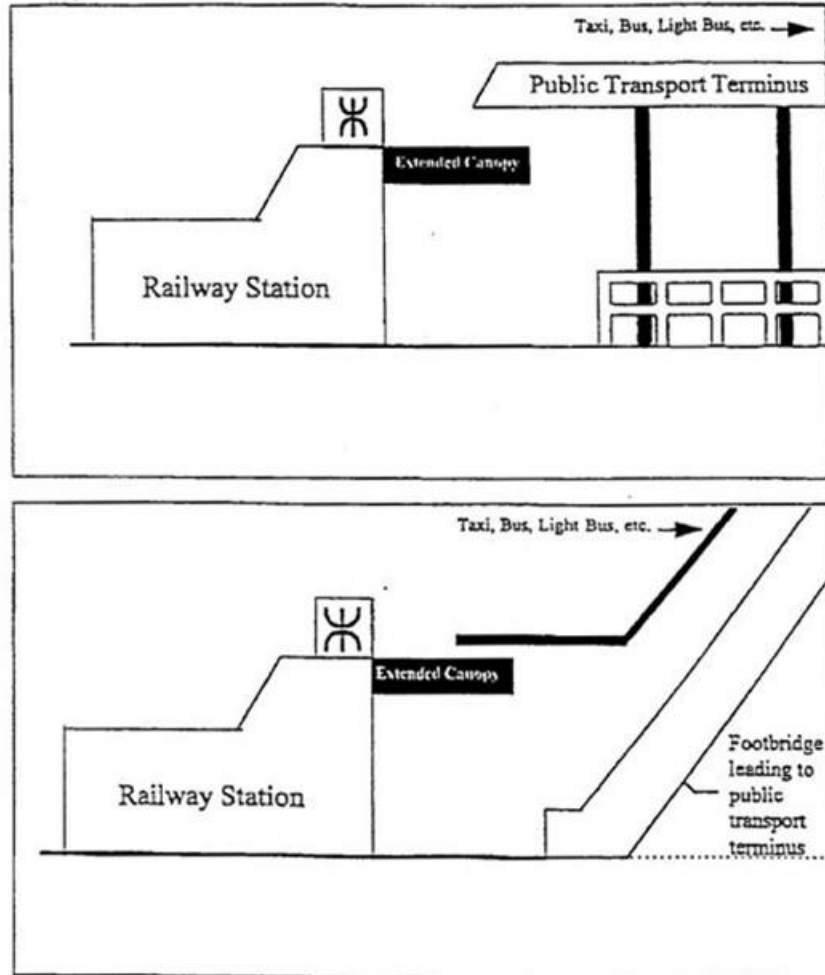

- 8.11.10 In Hong Kong, most public transport services are operated at high frequency. Hence, passengers suffer relatively little delay if they just miss a bus or train. Planner and operator can consider to provide the following facilities to reduce the adverse effect of waiting in the interchange:
- a congenial, clean, secure, climate controlled waiting environment with good ventilation, adequate capacity, possibly including seating;
 - high quality information system, especially on the expected departure time of the next service on each route; and
 - kiosks, refreshment facilities, toilets, sale of smartcards and smartcard added value machines, etc, to allow passengers to make the best use of their time spent at the interchange.
- 8.11.11 Apart from minimising passengers' walking and waiting time for interchange, there are other important passenger requirements. They include:
- To facilitate the boarding activities of passengers, the front part of the passenger platforms can be raised to around 180 mm using specially shaped or coated kerbs to eliminate the danger of tire damage. In conjunction with the use of low floor buses with a kneeling facility, this can achieve the step free boarding. The use of shallow saw-tooth bus bays (rather than parallel bays) tends to help bus drivers to pick up passenger with particular need immediately adjacent to the kerb.
 - More spacious waiting areas, and queuing lines should be provided at the cross-boundary bus stop since cross-boundary passengers will likely be carrying luggages.
- 8.11.12 For the introduction of through fares or reduced fares, the following arrangements may be required:
- adoption of an electronic ticket system such as contactless smart card;
 - use of transfer ticket; or
 - operation of a closed interchange with full electronic system like the contactless smart cards which permits through ticketing for interchanges at any point in the public transport system.
- 8.11.13 The results of some focus group researches in Hong Kong show that passengers consider the availability of public toilet essential. This is in line with the findings of similar surveys in other countries. It is recommended that public toilets should be provided at railway stations or PTIs if they are not available in nearby developments subject to comments from Food and Environment Hygiene Department.
- 8.11.14 Passengers also prefer the provision of seating facilities at waiting area. This will however be subject to space availability. Table 8.11.14 shows the proposed facilities and equipment within a PTI for passengers.

Table 8.11.14 Proposed Facilities and Equipments within PTI for Passengers

Facilities	PTI		Remarks
	NRS ⁽¹⁾	RS ⁽²⁾	
Toilets	E	E	Toilets could be provided as part of the development surrounding a PTI. Signs to direct people to toilets are essential. If not available in nearby developments, they should be provided in railway station or PTI. However, location of toilets within PTIs should be carefully designed to minimise nuisance to public.
Shelter or cover	E	E	Footbridges, footpath, concourse, waiting area & platform at PTI & RS should be sheltered.
Air conditioned waiting area	D	E	Only suitable for sawtooth-type PTI.
Seating facilities	O	O	Only required for long distance travellers & subject to space availability.
Luggage storage	O	O	Only required for long distance travellers.
Ticket office	O	E	
Ticket machines	O	E	Including machine for contactless smartcards.
Post box	O	O	Subject to the discretion of Post Master General
Retail outlets or kiosks	O	D	Including news agent, retail and snack-bar
Public telephone	E	E	Could include internet access facilities and cellular radio repeaters
Banking facilities	O	D	Optional in PTI and subject to space availability.
Travel agents	O	O	Only required for stations with long distance travellers and subject to space availability.
Regulator office and store room	E	E	Exact requirement to be advised by operators and will depend on the number of services operated from the PTI. A store room should be provided for operators for storage of water tanks, bus route number plate, destination plate, route information indicators, cabinets for minor maintenance tools, lifting platform, driver seat pads and other miscellaneous items. A store room of about 25 square metres will be adequate for a terminus of about 7 bus bays.
Fire service equipment	E	E	Should meet Fire Services Department's requirement

Note:

(1) - NRS: PTI without railway station

(2) - RS: PTI with railway station

Essential, D: Desirable, O: Optional

8.12 Operators Facilities

- 8.1.1 In some interchanges, the same bays are used for both unloading and loading bus passengers. In other designs, passengers are set down at a common unloading point and buses will then proceed to separate loading bays. Buses on terminating services are also required to take layover or to be parked for longer periods for driver meal breaks. In most designs of interchange in Hong Kong, the operator's required bus parking area is integrated with the loading and unloading area.
- 8.1.2 Other operator requirements include toilet, washroom, locker rooms and snack bar facilities for staff, and regulators' offices. For PTI used by more than one operator, some essential facilities for operation of services, e.g. regulators' offices, will be provided separately at different locations within the PTIs.